

Fuji Digital Controller Compact Controller M <CC-M>

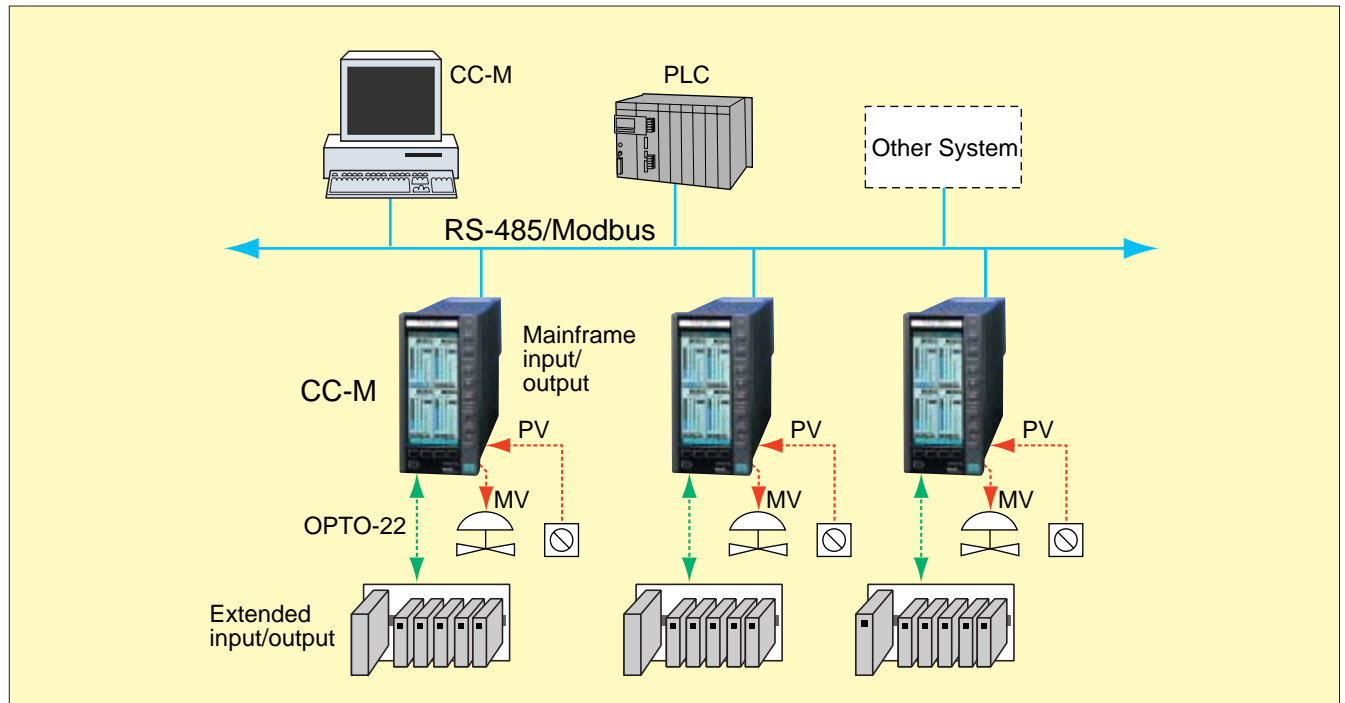

Open network

High-level communications using Modbus protocol allows the CC-M to be connected to a PLC or PC. OPTO22 I/O modules can be connected to each CC-M using low-level communications.



A variety of control functions

- Single loop control
- Multi-loop control
- Cascade control
- Ratio control
- Program control
- Multi-point input selection control
- Various advanced control
- Sequence logic + loop control

Examples of application system

- **Water treatment**
Water distribution control, pump control, chemical injection control
- **Utility plants**
Water supply control, drum water level control, combustion control
- **Combustion furnaces**
Batch type furnace, continuous furnace
- **City gas**
Manufacture process, heating power adjustment, distribution control
- **Incinerator plants**
Combustion temperature control, blower and exhaust control
- **Others**
Autoclave instrumentation, open channel flow computation, multi-point gas analyzer switching computation

FUJI Electric declares a multi-loop controller era

The Compact Controller M is a multi-loop controller of a new era where functions of 4 controllers are compactly built into a single unit.

A 16-color liquid crystal display presents information in highly visible way, from multi-loop bar graph display screen to trend screen and menu screen.

Oriented to user friendly operation, the multi-loop controller with innovated operability and functionality configures a flexible high performance system.



Controls up to 4 cascade control loops (4 control outputs)

- Up to 8 PID controls and 4 control outputs (4-20 mA DC) per unit are available.
- Use of OPTO 22 interface allows the increase of auxiliary analog input/output up to 4 points and auxiliary digital input/output up to 32 points in addition to the mainframe input/output (up to 16 points analog input/output & up to 21 points digital input/output).
- For safety process operation, a backup operation unit for 1 to 4 loops of 4-20 mA DC output can be incorporated.

As shown below, a combustion application controlled by four single loop controllers can be complemented with a single CC-M.

[Heating furnace/continuous furnace combustion control]

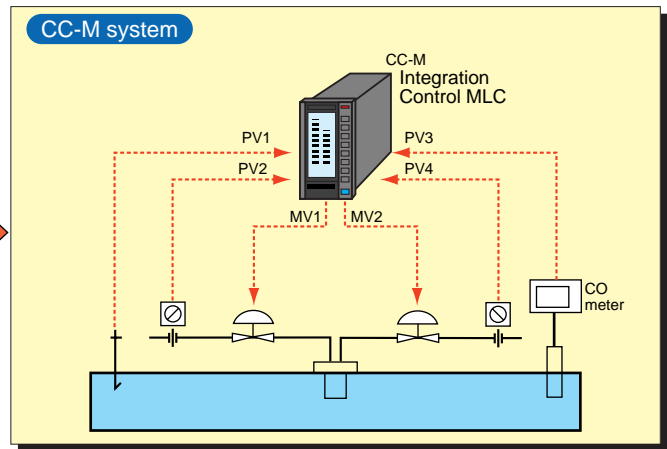
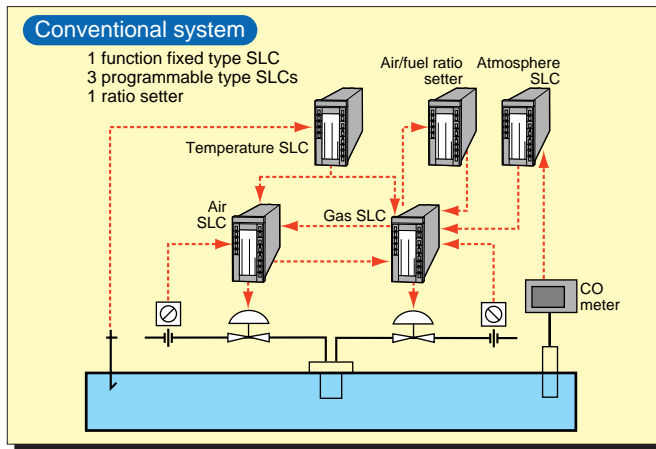

Soft logic functions (optional)

- Use of a PLC function programming language conforming to international standard IEC 61131-3 allows loop control and logic control functions (ladder: 2 k steps).

As shown below, control applications which utilize single loop controllers and external alarm relays can be executed with the CC-M's advanced software capabilities.

[Sequence Logic & Loop control]

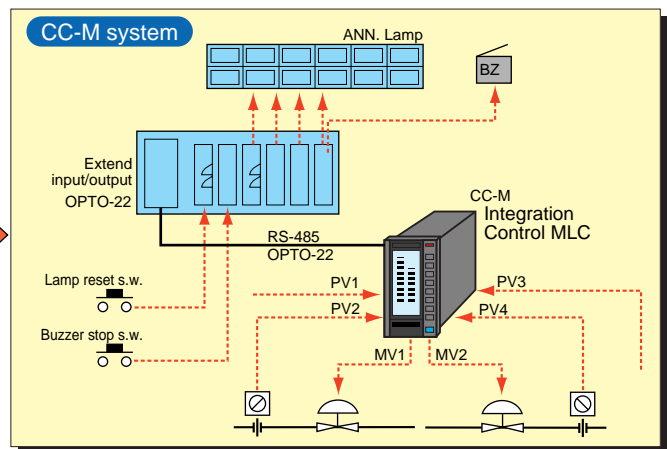
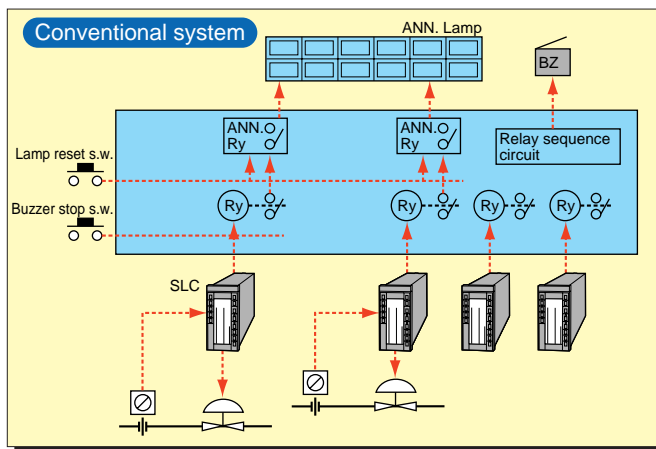

Trend data indication and saving

- Up to 32 trends can be indicated.
 - IC memory card can save trend data.
- Storage capacity: Approx. 1.35 million points of data by Compact Flash memory of 30MB.

Versatile graphic indication

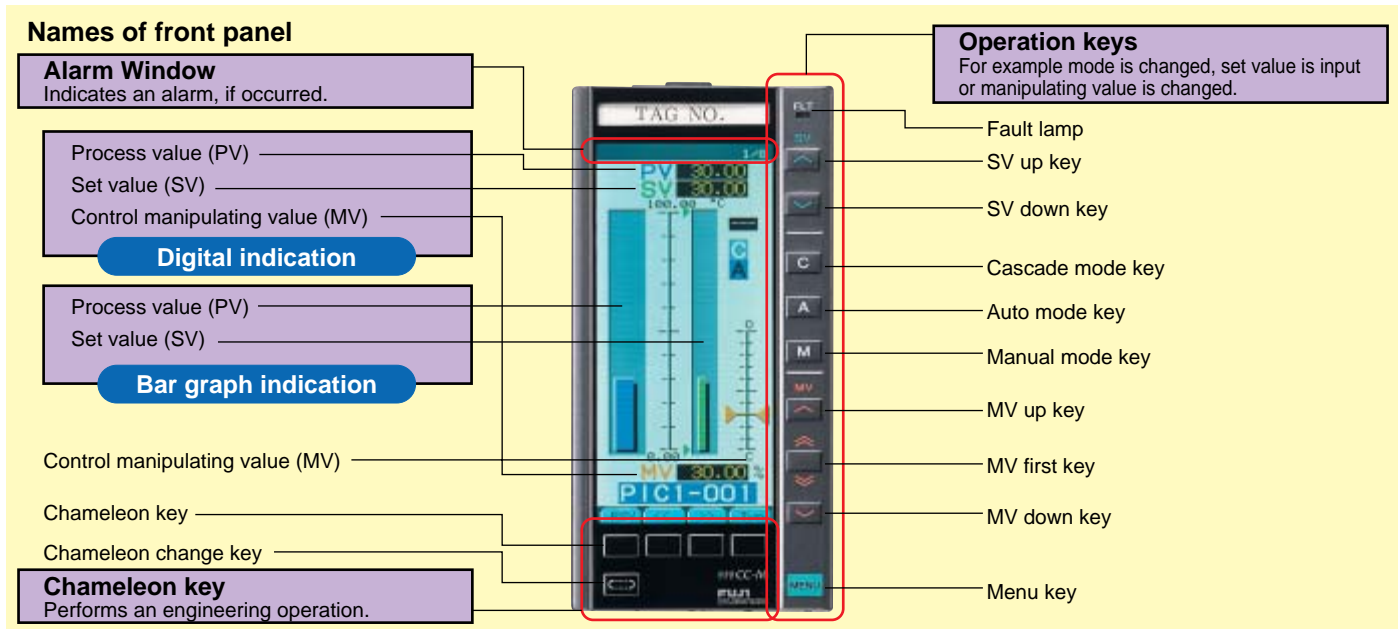

Versatile graphic indication

There are 3 main menu screens from which all programming parameters and process displays can be selected. At any time during the selection process, the user can return to the main menu screen by pressing the "Menu" key.

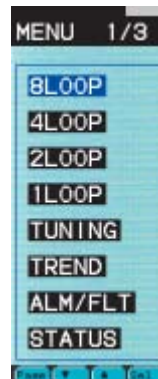

Menu screen 1/3 can select any of 8 different monitoring/operation screens.



Menu screen 2/3 can mainly select any of 8 different parameter setting screens.



Menu screen 3/3 can select any of 5 different screens related to system definition.

Password function provided for avoiding wrong setting

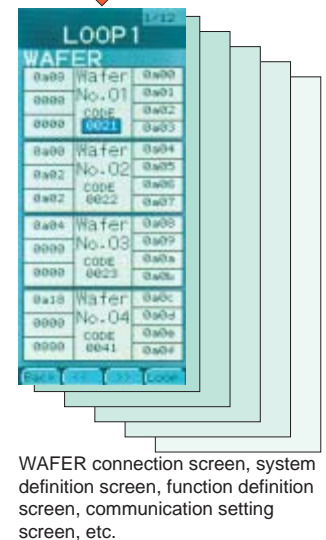
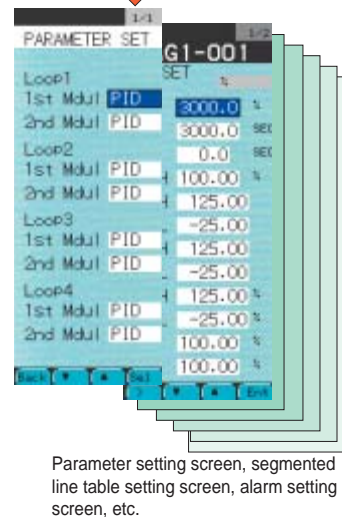
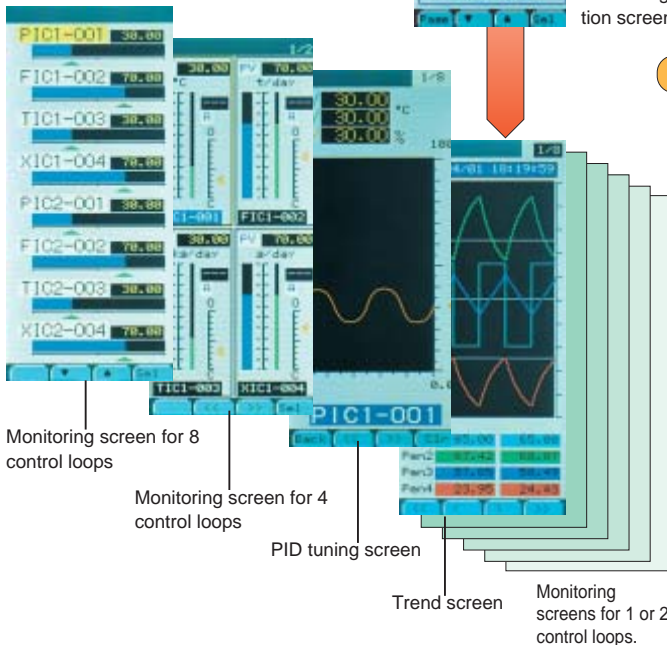

Support screens which further details the supervision of process statuses

- Alarm logging screen : Records alarm ON/OFF times, alarm kinds and Tag No.
- Alarm status screen : Indicates currently occurred alarm.
- Input/output indication screen : A screen capable of monitoring all input/output data is provided.
 - AI, AO, DI & DO monitoring
 - Communication data
- Wafer input/output monitoring screen : Monitors all internal computation data.
 - Analog data, ON-OFF data
- Indication loop setting screen : Can indicate arbitrary analog data as a loop.

Configuration



[Programming loader]

The CC-M can be programmed from the front display or by using Fuji's Windows-based configuration software. Using this software, the configuration file is downloaded via an RS-232 transmission cable.



[Soft logic configurator]

Using the PLC control language conforming to IEC 61131-3, a program is created on a PC. A program corresponding to 2 k steps of ladder can be created. Ladder diagram, sequential function chart, function block diagram can be handled.

Configuration is also available through graphic display unit and keys.

WAFER connection

The CC-M software is configured by using function blocks called "WAFERS."

The CC-M control and computation functions can be programmed by selecting among the 100 types of available WAFERS. Each WAFER contains I/O address locations which are used to link the WAFERS.

For example, an input for a first-order PID computation is available from the screen using WAFER Nos. 21, 22 and 23.

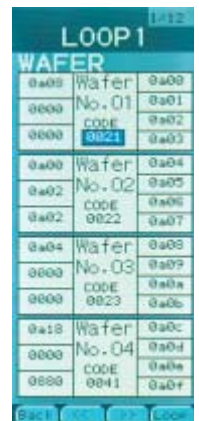
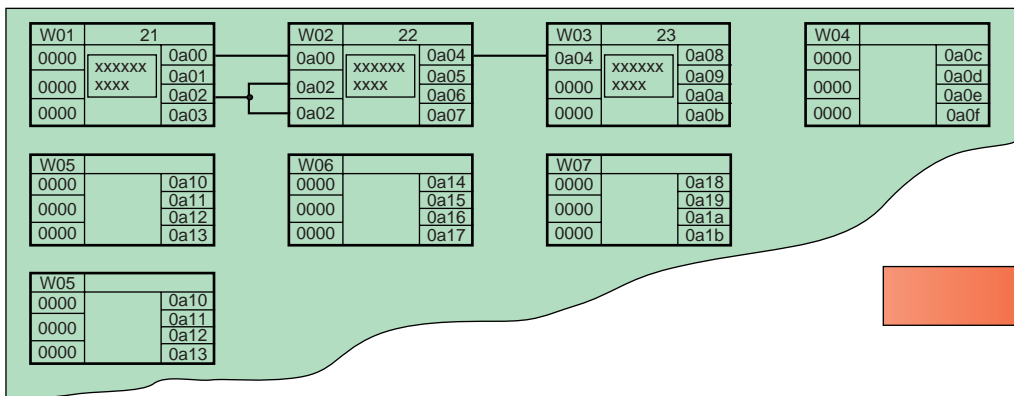

PC-based control system

Used together, the CC-M Controller and the Windows NT-based software package can offer a high-performance control and monitoring system. This software can connect a maximum of 8 CC-M's via an RS-485 communications (Modbus protocol) network. Because additional I/O devices can be connected to each CC-M via low-level RS-485 communications, a small-scale PC-based control system can be configured economically.

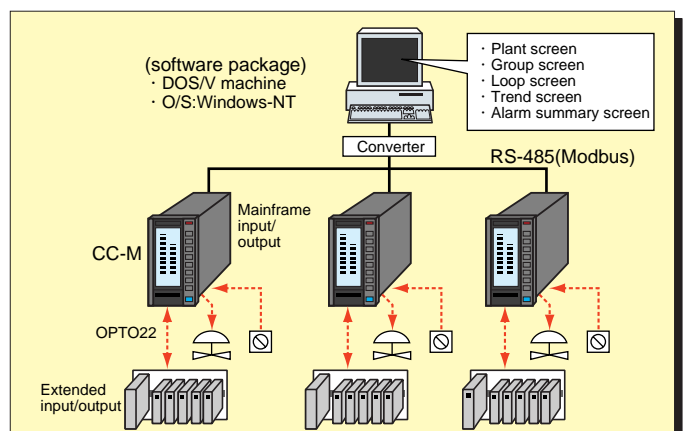

■ Specification

Type	PDA	Specification
Control and Computation Functions	Number of loops and PID	1 loop (1 control output/ 2PID) 2 loop (2 control output/ 4PID) 4 loop (4 control output/ 8PID)
	Programming method	WAFER connection method / Soft Logic method
	Program capacity	48 WAFER x 4 loops (max. 192 WAFERS / max. 2k steps)
	Kind of WAFER	about 100 kinds
	Computation cycle	200 ms for 4 loop (8PID) control of simplicity PID
	Operation mode	Cascade-Auto-Manual
Analog	Input signal	Number of inputs : 8 *(7 input) Input signal type : DC voltage, Thermo couple, Resistance bulb. [Note] Two thermo couple or two resistance bulb inputs are selectable. Shunt resistor need to be connected to the analog input terminal. (250Ω shunt resistor is optional item)
	Output signal	Control output: Selectable among 1, 2 and 4 outputs (DC4-20mA) Auxiliary output: 4 output (DC 0-5V, DC 1-5V, DC 0-10V) *(5 output)
Digital	Input signal	10 point (ON /0V, OFF /24V)
	Output signal	11 output (Transistor open collector)
Display		Color graphic LCD with back light
Power supply		AC 100V (-15%)~240V (+10%) 50/60Hz, DC24V(DC20V~30V)
Backup Function	(Option)	Built-in Number of control outputs: 1, 2 or 4 output selectable. (DC4-20mA)
Communications	(Option)	RS-485 (Modbus protocol, OPTO22 interface)
Memory Card Interface	(Option)	Compact Flash Capacity 4,20 and 30MB
Configuration Software	(Option)	Programming loader and Soft logic configurator. (Windows 95)
Soft logic Function	(Option)	Based on IEC61131-3 standard languages.

*Screw terminal type.

■ Dimension [Unit:mm]

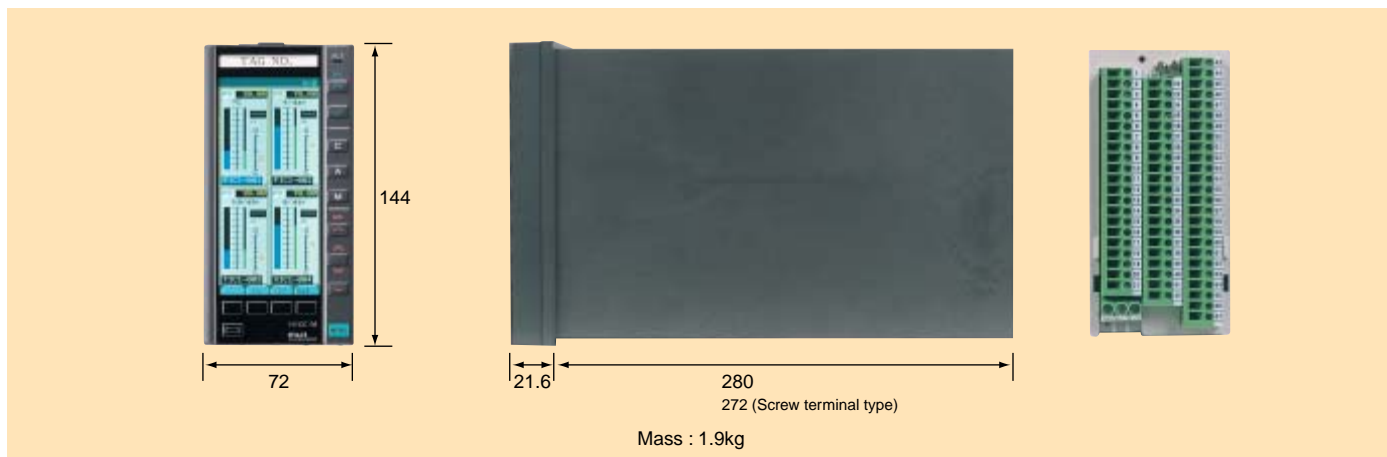

⚠ Caution on Safety

* Before using this products, be sure to read its instruction manual in advice.

[NOTE] Windows 95/NT is the registered trade mark of Microsoft Corporation.

[NOTE] Modbus is the registered trade mark of Gould Modicon.

[NOTE] Compact Flash is the registered trade mark of Sandisk corporation.

[NOTE] OPTO22 interface is the registered trade mark of OPTO22.

Fuji Electric Systems Co., Ltd.

Head Office
Gate City Ohsaki, East Tower,
11-2, Osaki 1-chome, Shinagawa-ku, Tokyo 141-0032, Japan
<http://www.fesys.co.jp/eng>

**Instrumentation Div.
International Sales Dept.**
No.1 , Fuji-machi, Hino-city, Tokyo,191-8502 Japan
Phone : 81-42-585-6201,6202
Fax : 81-42-585-6187
<http://www.fic-net.jp/eng>