

# THERMAL CONDUCTIVITY GAS ANALYZER ZAF

Optimum for concentration measurement for H<sub>2</sub>, Ar and He.



- Operation facilitated with easy-to-read, large LCD panel.
- Free voltage on 100 to 240V AC, 50/60Hz.
- RS232C (MODBUS) communication. (option)
- Automatically calibrates zero/span. (option)
- Computes and corrects influence by other gases. (option)
- Gas concentration alarm output. (option)
- Two measuring range. (option)

# Renewed with fresh design ZAF

## Feature 1 Easy-to-read, large LCD.



● Operation is facilitated with the aid of guidance in English.

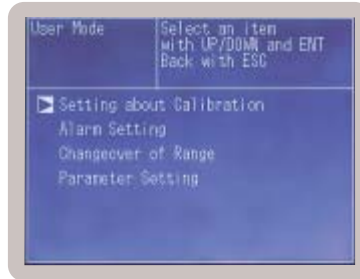

## Feature 2 PC communication available.



Personal Computer

RS232C (MODBUS) for measurement value, setting range read/write, device status output.



## Feature 3 Compact size mountable on panel.

Mountable in same panel cutout as heretofore.



(Unit mm)

Mass 5kg.

## Feature 4 Automatically calibrates zero/span. (option)

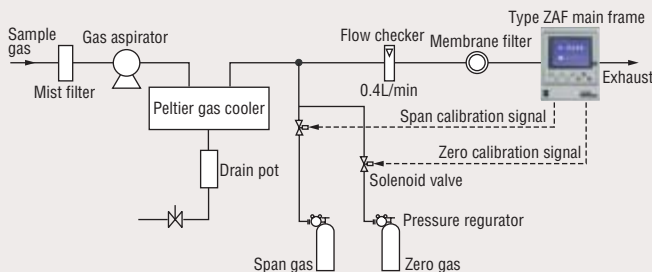

## Feature 5 Computes and corrects influence by other gases. (option)

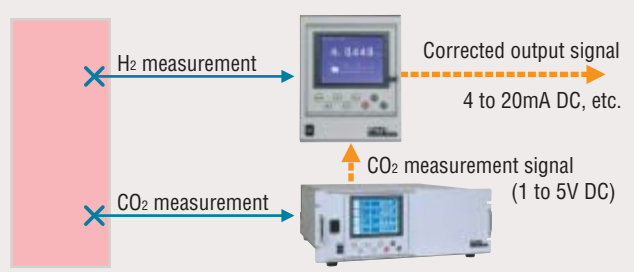

## Feature 6 Gas concentration alarm output. (option)



Alarm output (1a relay contact) selectable for:

- High limit
- Low limit
- High-high limit
- Low-low limit

## Feature 7 Two range. (option)

- A range selected by key on front panel or by external contact closure command.
- Range ratio Up to 1:10 for H<sub>2</sub> or He measurement, Up to 1:5 for Ar, CH<sub>4</sub> or CO<sub>2</sub> measurement.

## Feature 8 Linear measurement output signal. (option)

- Dispenses with external linearizer.

## ● Main applications

- H<sub>2</sub> concentration measurement for semiconductor equipment.
- H<sub>2</sub> concentration measurement for hydrogen generator.
- H<sub>2</sub> concentration measurement for kiln.
- Ar, He or CH<sub>4</sub> concentration measurement for gas generation plant.
- He concentration measurement for super-conducting equipment.
- Ar concentration measurement for air separation plant.

## ● Thermal Conductivity Ratio of Gases

Gases	Comparative thermal conductivity (0°C) when replacing thermal conductivity of air (2.41 x 10 <sup>-2</sup> w/(m.k) with 1
Sulfur dioxide gas	SO <sub>2</sub>
Carbon dioxide gas	CO <sub>2</sub>
Argon	Ar
Carbon monoxide	CO
Steam (100°C)	H <sub>2</sub> O
Air	1
Nitrogen	N <sub>2</sub>
Oxygen	O <sub>2</sub>
Methane	CH <sub>4</sub>
Hydrogen	H <sub>2</sub>

## ● Measuring Principle

This thermal conductivity gas analyzer measures gas concentration by utilizing the different thermal conductivities of 2 gas components. In the detector, there are reference and measuring chambers in each of which a thin platinum wire is stretched. The reference chamber is filled with reference gas and through the measuring chamber, sample gas is flowed. Each platinum wire composes a bridge circuit in combination with an external fixed resistor, and it is heated by flowing a constant current. When there is a change in the concentration of the component under measurement, the thermal conductivity of sample gas will change to affect the temperature of the platinum wire in the measuring chamber. The resulting thermal change is taken out as a change in electric resistance, according to which the concentration of measured gas is calculated.

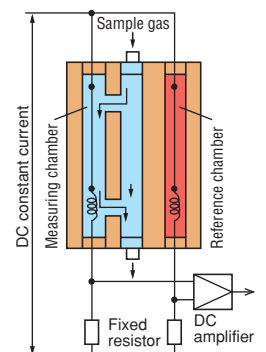

# Specifications

## Standard Specifications

<b>Measuring principle</b>	Measurement of thermal conductivity
<b>Measurable component</b>	He, Ar, H <sub>2</sub> , CH <sub>4</sub> , CO <sub>2</sub>
<b>Measurable range</b>	As specified for particular type.
<b>Output signal</b>	4 to 20mA DC, 0 to 1V DC, 0 to 10mV DC Non-isolated output (Any one-output signal specifiable in CODE SYMBOLS)
<b>Allowable load resistance</b>	550Ω max. (in 4 to 20mA DC output)
<b>Output resistance</b>	100kΩ (in 0 to 1V DC or 0 to 10mV DC output)
<b>Display unit</b>	LCD with backlight
<b>Display of measured value</b>	Max. 4 digits
<b>Display language</b>	English
<b>Output signal holding</b>	In both manual and automatic calibrations, output value just before calibration can be held.
<b>Power supply</b>	100 to 240V AC, 50/60Hz, Approx. 50VA
<b>Warm-up time</b>	At least 30min
<b>Ambient temperature</b>	-5 to 45°C
<b>Ambient humidity</b>	Less than 90% RH (condensation unallowable)
<b>Storage conditions</b>	-20~60°C, less than 95% RH (condensation unallowable)
<b>Mounting</b>	Flush mounting on panel
<b>External dimensions (H×W×D)</b>	240×192×213mm
<b>Mass</b>	Approx. 5kg
<b>Finish color</b>	Off-white (equivalent to 10Y7.5/0.5)
<b>Housing</b>	Steel-plate case, indoor type
<b>Material of gas-contacting parts</b>	JIS SUS304, platinum, platinum iridium, silver, fluororubber, epoxy resin, nickel, tin
<b>Gas inlet/outlet, purge port</b>	Rc1/4 or NPT1/4 (whichever specified)
<b>Purge gas flow rate</b>	Approx. 1L/min (as required)
<b>Applied standard</b>	CE mark (pending)

## Performance

<b>Repeatability</b>	±1% of F.S.
<b>Drift</b>	Zero point: Within ±2% of full scale/week (H <sub>2</sub> meter, reference gas N <sub>2</sub> ) Span: Within ±2% of full scale/week (H <sub>2</sub> meter, reference gas N <sub>2</sub> )
<b>Response speed (90% response)</b>	Standard within 60sec (at flow rate 0.4L/min) High speed within 10sec (at flow rate 1L/min), allowed only for H <sub>2</sub> meter (reference gas N <sub>2</sub> )

## Standard Gas Measurement Conditions

<b>Temperature</b>	0 to 50°C
<b>Gas flow rate</b>	Constant at 0.4±0.05 L/min
<b>Dust</b>	Less than 100μg/Nm <sup>3</sup> with a particle size of 0.3μm max.
<b>Pressure</b>	10kPa max.
<b>Mist, Corrosive gas</b>	Unallowable
<b>Moisture</b>	Below saturation at 2°C
<b>Standard gases for calibration</b>	Zero gas: same as reference gas Span gas: Concentration within 90 to 100% of measuring range Concentration beyond 100% is inapplicable.

## Optional Specifications

<b>Linearization</b>	Linearize measurement value output signal. (4 to 20mA DC) Linearity within ±2% of F.S.
<b>Relay contact output</b>	5 SPST relay contact outputs Relay contact capacity; 220V AC/2A (resistive load) Isolated with relay between contacts, and between contacts and internal circuit. Max. 5 functions are selectable among those listed below. ① Zero-side solenoid valve drive output for automatic calibration ② Span-side solenoid valve drive output for automatic calibration ③ Suction pump OFF output in automatic calibration ④ Upper limit (1point) concentration alarm output ⑤ Lower limit (1point) concentration alarm output ⑥ Upper/lower limit (1point) concentration alarm output ⑦ Upper limit (1point) and lower limit (1point) concentration alarm output (Total 2 points) ⑧ 2-step upper limit (1point at each step) concentration alarm output (Total 2 points) ⑨ 2-step lower limit (1point at each step) concentration alarm output (Total 2 points) ⑩ Analyzer error or automatic calibration error alarm output ⑪ Calibrating status output ⑫ Range identification output (for 2 range type only)
<b>Contact input</b>	3 non-voltage contact inputs ON; 0 V, OFF; 5V DC, current at ON; 5mA Isolated with photo coupler between inputs and internal circuit. Not isolated between contact inputs. The following actions can be input. ① Remote holding of measured value output ② Remote range changeover (only with 2-range meter) ③ Remote start of automatic calibration
<b>Interference gas measured value input</b>	Analog input for H <sub>2</sub> meter interference correction (1 to 5V DC) Either CO <sub>2</sub> or CH <sub>4</sub> component of an external gas analyzer is to be input. Adjustment is required at Fuji Electric's factory. Details of measurement gas will be checked when receiving an order.
<b>Automatic calibration function</b>	Zero and span calibrations are automatically carried out at the predetermined intervals. Calibration gases are flowed sequentially by driving the externally installed solenoid valves.
<b>Communicating function</b>	RS-232C (9-pin D-sub output) Half duplex, asynchronous MODBUS™ protocol, communication speed 9600 bps Contents of communication: Reading/writing of measured concentration values and various set values, and output of device status

## Installation Conditions

- The analyzer should not be exposed to direct sunlight or radiation from a hot object.
- A place subjected to heavy vibrations should be avoided. A location with clean atmosphere should be selected.
- Before measuring combustible gases, the existing gases should be purged from the analyzer using air or N<sub>2</sub>.
- When the analyzer is installed outdoors, it should be sheltered with a housing or cover to protect it from rain and wind.

## Outline Diagram

(Unit: mm)

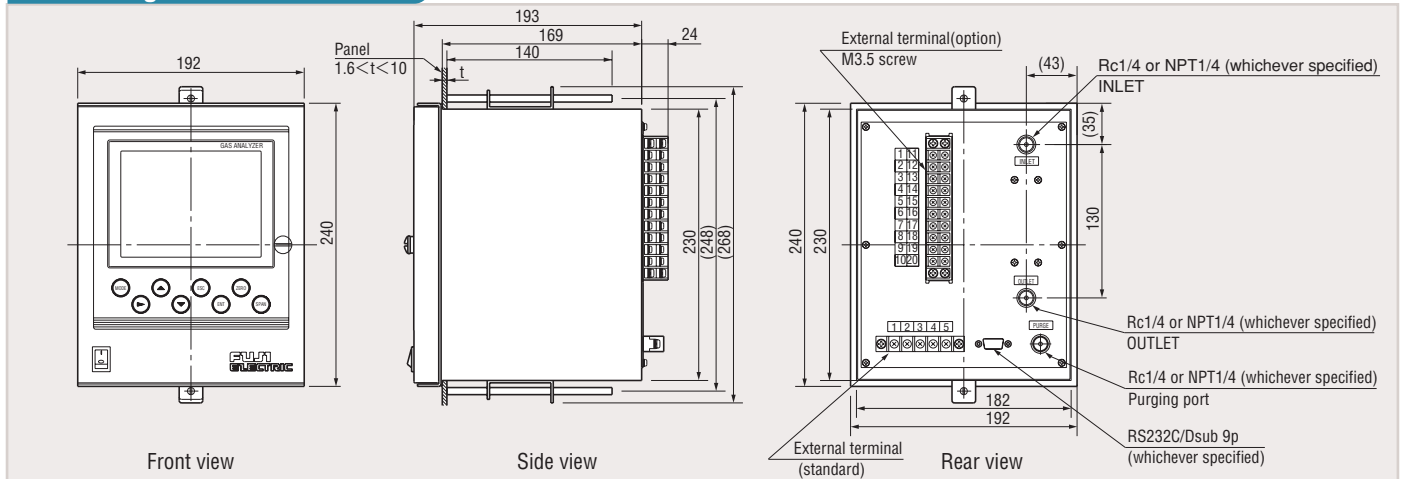

## Panel Cutout

(Unit: mm)

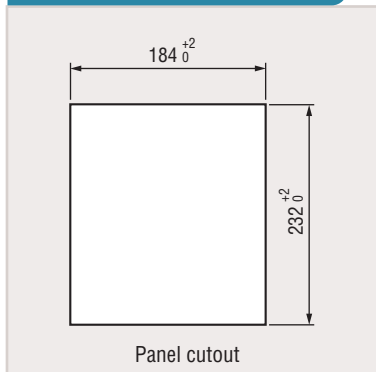

## Connection Diagram

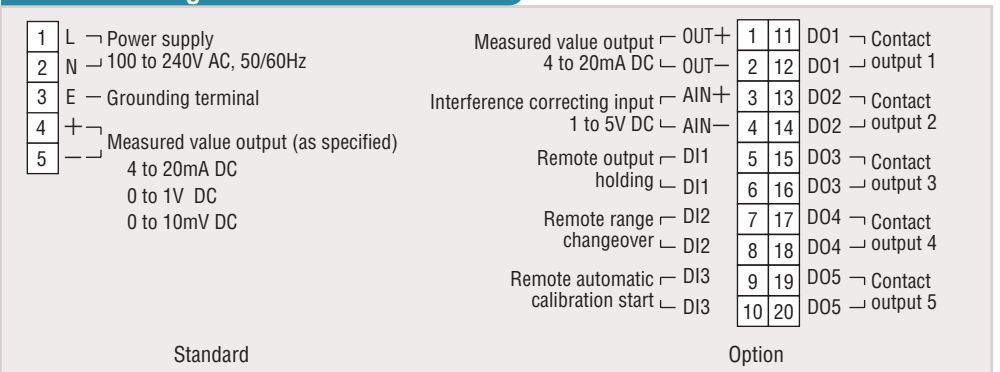

# Code Symbols

ZAF 4 5 6 7 8 9 10 11 12 13 14

Digit	Description	4	5	6	7	8	9	10	11	12	13	14
4	< Indication, response > Indication in English, standard response Indication in English, high-speed response				E	H						
5	< Measured component > H <sub>2</sub> Ar He CH <sub>4</sub> CO <sub>2</sub> (reference gas Ar unallowable) Other		K	L	M	E	A	Z				
6	< Reference gas > (Note 1) N <sub>2</sub> Air (incompatible with H <sub>2</sub> /CH <sub>4</sub> measurement) O <sub>2</sub> (incompatible with H <sub>2</sub> /CH <sub>4</sub> measurement) Other			4	5	6	Z					
7	< Power supply, connection port size > AC100 to 240V 50/60Hz, Rc1/4 AC100 to 240V 50/60Hz, NPT1/4					0	1					
8	< Revision No. >						3					
9	< Measuring range (1st range) > 0 to 3% (H <sub>2</sub> ) 0 to 5% (H <sub>2</sub> , He) 0 to 10% (H <sub>2</sub> , He, Ar, CO <sub>2</sub> ) 0 to 20% 0 to 30% 0 to 50% 0 to 80% 0 to 100% 100 to 90% (H <sub>2</sub> , He, Ar) 100 to 80% (H <sub>2</sub> , He, Ar, CH <sub>4</sub> ) Other							Q	L	M	N	V
10	< Measuring range (2nd range) > (Note 2) None 0 to 5% (H <sub>2</sub> , He) 0 to 10% (H <sub>2</sub> , He, Ar) 0 to 20% (H <sub>2</sub> , He, Ar, CO <sub>2</sub> ) 0 to 30% 0 to 50% 0 to 80% 0 to 100% Other								Y	L	M	N
11	< Measured value output > DC4 to 20mA DC0 to 1V DC4 to 20mA + RS-232C communication DC 0 to 1V DC + RS-232C communication DC0 to 10mV									A	B	C
12	< Linearization > None Provided										Y	A
13	< H <sub>2</sub> meter interference corrective calculation > (Note 3) None Provided										Y	A
14	< Input/output contacts > None Automatic calibration Automatic calibration Concentration alarm Concentration alarm Contact output selection Contact output selection											Y
												A
												B
												C
												D
												E
												F

**Note 1** Reference gas refers to each of main components other than component under test in sample gas. Contact us if there is more than one remaining gas component or remaining gas component is other than given above.  
Example: If hydrogen in nitrogen is measured, nitrogen is the reference

**Note 2** The ratio of maximum range to the first range is as given below.  
For CO<sub>2</sub>, Ar or CH<sub>4</sub> measurement: 1st range ×5 (times)  
For He or H<sub>2</sub> measurement: 1st range ×10 (times)  
A range from 0 to...% cannot be combined with that from 100 to...%.

**Note 3** [Only single range H<sub>2</sub> meter] A CO<sub>2</sub> or CH<sub>4</sub> meter needs to be prepared separately.  
A reverse range such as 100 to 0% cannot be specified.  
Input signal is 1 to 5V DC. (1range only)  
Adjustment is required at Fuji Electric's factory.  
Details of measurement gas will be checked when receiving an order.

Input/output contact specifications		14th digit:A	14th digit:B	14th digit:C	14th digit:D	14th digit:E	14th digit:F
		Automatic calibration related	Concentration alarm related	Concentration alarm related	Contact output selection (Note 7)	Contact output selection (Note 7)	Contact output selection (Note 7)
Automatic calibration related	Zero gas valve drive	○(D01)	○(D01)	—	—	○	○
	Span gas valve drive	○(D02)	○(D02)	—	—	○	○
	Suction pump OFF in automatic calibration	●(D03)	●(D03)	—	—	●	●
Concentration alarm related	Upper limit (1 point) concentration alarm	—	—	—	—	—	—
	Lower limit (1 point) concentration alarm	—	—	—	—	—	—
	Upper/lower limit (1 point as a set) concentration alarm	—	—	—	—	—	—
	Upper limit (1 point) and lower limit (1 point) concentration alarm	—	—	—	—	—	—
	2-step upper limit (1 point each) concentration alarm	—	—	—	—	—	—
Other	Calibration status	○(D04)	●(D04)	○(D04)	●(D04)	○	●
	Range information (2-range meter)(Note3)	—	—	○(D03)	—	○	○
	Analyzer error or automatic calibration error	○(D05)	●(D05)	○(D05)	●(D05)	○	●
Contact output	Remote automatic calibration start (Note4)	○(D13)	○(D13)	○(D13)	○(D13)	○(D13)	○(D13)
	Remote range changeover (2-range meter)(Note5)	○(D12)	○(D12)	○(D12)	○(D12)	○(D12)	○(D12)
	Remote measured value output holding (Note6)	○(D11)	○(D11)	○(D11)	○(D11)	○(D11)	○(D11)

(Note 1) Mark○: Normally Open (NO) contact  
(Note 2) Mark●: Normally Closed (NC) contact, after turning on power supply  
(Note 3) Low range: Contacts close, High range: Contacts open  
(Note 4) When contacts open 1.5 sec after their closure, automatic calibration starts.  
(Note 5) Contacts closed: Low range, Contacts open: High range  
(Note 6) Contacts closed: Holding, Contacts open: Holding canceled  
(Note 7) Up to 5 contact outputs can be set.

## SCOPE OF DELIVERY

Analyzer main unit  
Panel mounting brackets (1 set)  
2 power fuses (250 V AC, 1 A)  
Instruction Manual

## ITEMS TO BE PREPARED SEPARATELY

Gas sampling equipment, standard gas, receiving instrument, etc.  
With interference corrective calculation: CO or CO<sub>2</sub> gas analyzer

## ORDERING INFORMATION

1. Analyzer type
2. Gas component to be measured
3. Measuring range
4. Gas component other than measured



ISO 14001 JQA-EM2492  
ISO 9001 JQA-2275

# Fuji Electric Systems Co., Ltd.

**Head Office**  
Gate City Ohsaki, East Tower,  
11-2, Osaki 1-chome, Shinagawa-ku, Tokyo 141-0032, Japan  
<http://www.fesys.co.jp/eng>

**Instrumentation Div.**  
**International Sales Dept.**  
No.1, Fuji-machi, Hino-city, Tokyo, 191-8502 Japan  
Phone : 81-42-585-6201,6202  
Fax : 81-42-585-6187  
<http://www.fic-net.jp/eng>