

For gas measurement in a heat treat furnace

INFRARED GAS ANALYZER Type:ZFG



Two gas components (of CO, CO₂, and CH₄) can be measured simultaneously and continuously.

- The high-precision measurement of gas concentration in a furnace
Repeatability : Within 0.5% of the full scale
- Excellent prolonged stability and ease of maintenance achieved by the adoption of a single-beam system
- Measures the concentration of CO₂, CO, and CH₄ gases, which are associated with Carbon Potential (CP)
- CP calculation can be output and displayed (Option)
- Two gas components (CO₂+CO, CH₄+CO, and CO₂+CH₄) can be measured simultaneously and continuously
- Compact and lightweight
External dimensions : 218(W)×211(H)×257(D) mm (Volume ratio to our conventional products : Approximately 1/3)
Mass : Approximately 5kg (Ratio to our conventional products : Approximately 1/2)
- Convenient front mounting type
Panel cutout dimensions : 206(W)×173(H)

Compact and lightweight single-beam infrared gas analyzer

Easy-view large LCD

Instructions in Japanese facilitate operation. Provided with an auto OFF function.



2-component display

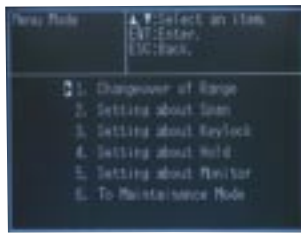

Menu mode

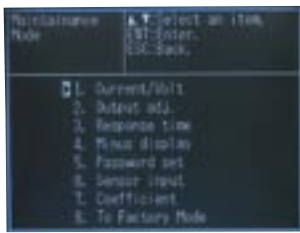

Maintenance mode

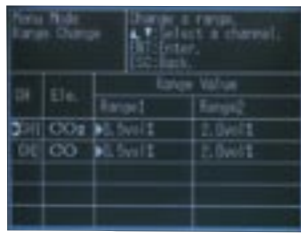

Range select mode



Type: ZFG

Simple key operation

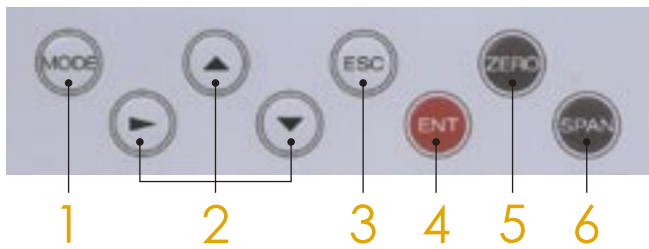

- 1 **Mode select key**
Used to switch modes.
- 2 **Up/down/right key**
Used to switch the items to be selected.
- 3 **Escape key**
Used to return to the previous screen or abort setting midway.
- 4 **Enter key**
Used to confirm the selected items and numeric values.
- 5 **Zero calibration key**
Used for manual zero calibration.
- 6 **Span calibration key**
Used for manual span calibration.

Excellent prolonged stability, easy maintenance, and high-precision measurement with repeatability of 0.5%FS or less

Principle The amount of infrared ray absorbed in the measuring cell is detected with the mass flow sensor.

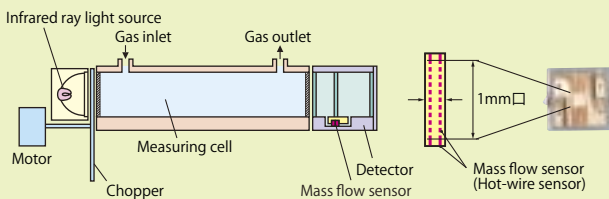

Mass flow sensor

The mass flow sensor, with low impedance, has excellent noise resistance, while the sensor, with no movable parts, is impervious to vibration and can be used on a semi-permanent basis.

The result of CP calculation is displayed and output. (Option)

Based on the CO₂ measurement, the carbon potential of a carburizing furnace or gas generator is calculated using the furnace temperature (fixed input value) and CO concentration (fixed value or actual measurement).



$$\text{Arithmetic expression : CP} = \frac{\text{CPS} \times (\text{PCO}_2)^2}{\text{K1} \times \text{PCO}_2}$$

t : Furnace temperature
 CPS : Saturated carbon concentration (partial pressure)
 0.0028t - 1.30 (800°C ≤ t < 850°C)
 0.0030t - 1.47 (850°C ≤ t < 950°C)
 0.0034t - 1.85 (950°C ≤ t < 1000°C)
 PCO : CO concentration (partial pressure)
 PCO₂ : CO₂ concentration (partial pressure)
 K1 : Constant K1 = 10 (9.06 - 15966/T)
 T : Rankine temperature (t × 9/5 + 32 + 460)

Short depth [Shorter by 286 mm than our conventional products]

Conventional items can be replaced. (Unit : mm)

Type ZAR (Discontinued in October 1998.)

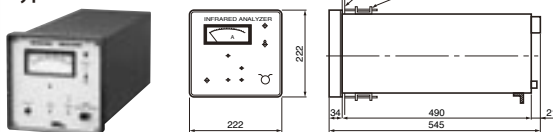

Type ZFU (Discontinued in September 2005.)

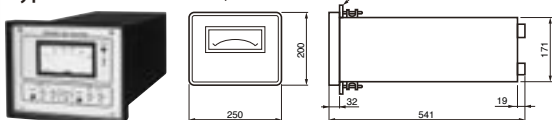

New ZFG



The panel cut dimensions differ from those of our conventional products. A mounting plate will be used for mounting.

Type	Front panel dimensions (Width × Height)	Panel depth	Panel cutout dimensions (Width × Height)	Mass
ZAR	222 × 222	511	206 × 206	12kg
ZFU	250 × 200	509	206 × 173	11kg
New ZFG	218 × 211	225	206 × 173	5kg

Concentration measurement and control of gases within the furnace ideal for quality control

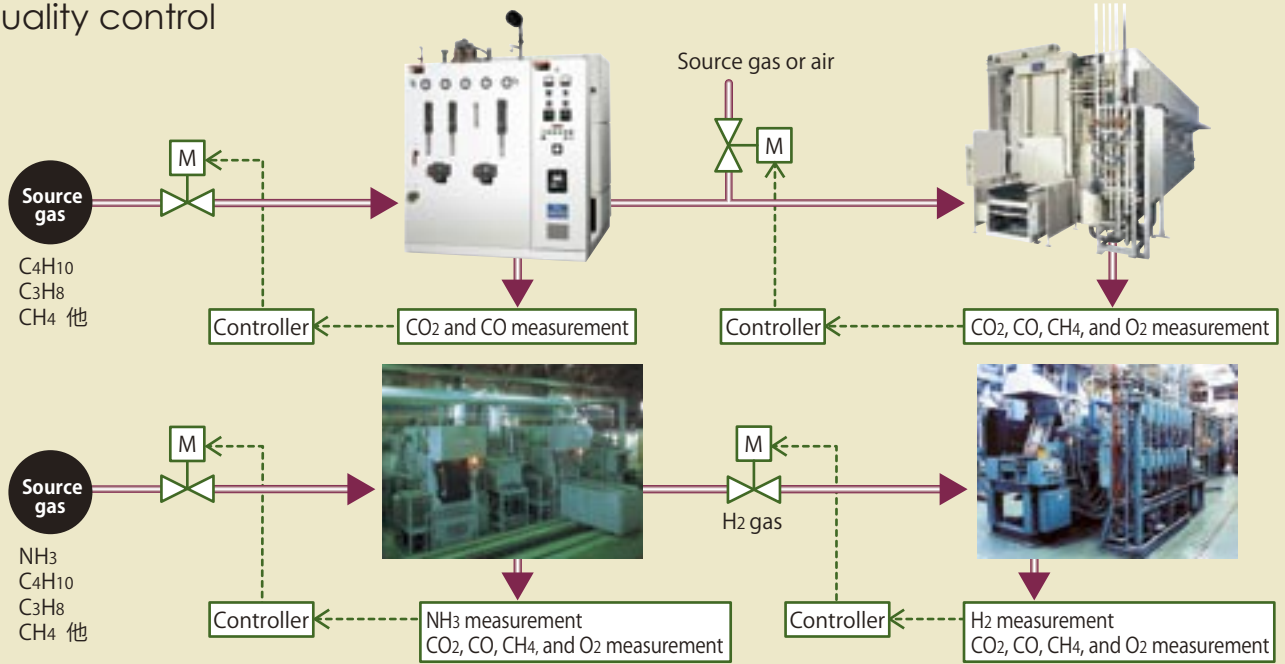

Basic sampling gas system

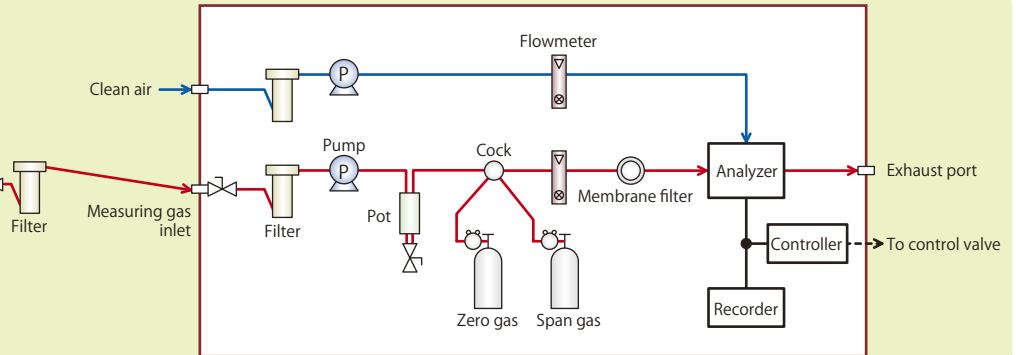

Related products

We provide various recorders and controllers which can be selected depending on applications.

Paperless Recorder

Type : PHR



Number of input points : 9points or 18points
Input circuit : Input mutual isolation, 4 to 20mADC, 1 to 5VDC, Thermocouple, Resistance bulb
Indicator : TFT color LCD
External memory media : Compact Flash card (256MB max.)

Microjet Recorder

Type : PHC



Input points : 1,2,3 or 6 continuous recording
6 intermittent recording
Input circuit : Input mutual isolation, 4 to 20mADC, 1 to 5VDC, Thermocouple, Resistance bulb
Chart width : 100mm
Chart length : 15m

Compact Controller M

Type : PDC



Control method : Sampling control system
Control mode : Auto, Remote, Manual
External setting value input : 1 to 5 VDC
Mode changeover : Manual, Remote
Motorized value control out put : SPST contact
Valve position feedback signal : 1 to 5VDC

Micro Controller X

Type : PXG



Input signal : 4to 20 mADC, 1 to 5VDC, Thermocouple, Resistance bulb
Control mode : Auto, Remote, Manual
External setting value input : 1 to 5VDC
Mode changeover : Manual, Remote
Motorized value control out put : SPST contacts
Valve position feedback signal : 100Ω to 2.5kΩ

Digital Controller

Type : PXH



Input signal : 4 to 20 mADC, 1 to 5VDC, Thermocouple, Resistance bulb
Control mode : Auto, Remote, Manual
External setting value input : 1 to 5VDC
Mode changeover : Remote
Motorized value control out put : SPST contacts
Valve position feedback signa : 100Ω to 10kΩ

Major specifications

Measurement principle	Non-dispersive infrared ray absorption (Single-beam system)			External contact input (option)	No-voltage contact Remote range switching, remote output signal hold
Measurable component and range	Measured component	Minimum range	Maximum range	Gas outlet / inlet dimension	Rc1 / 4 or NPT1 / 4
	CO ₂	0 ~ 0.5%	0 ~ 100 vol%	Purge gas flow rate	1L / min (Performed as required.)
	CO	0 ~ 0.5%	0 ~ 100 vol%	Coating color	Off-white (Munsell 10Y7.5 / 0.5 or equivalent)
	CH ₄	0 ~ 1%	0 ~ 10 vol%	Structure	Indoor type with steel case
	<ul style="list-style-type: none"> Up to 2 components can be measured. Switching between 2 ranges Maximum range ratio : 1:5 			Ambient temperature / humidity	-5°C to 45°C, 95% RH or lower (No condensation allowed.)
Repeatability	Within ± 0.5%FS			Warm-up time	Approximately 30 min
Linearity	Within ± 1.0%FS Within ± 2.0%FS (Range ratio : 1:4 or 1:5)			Mounting method	Front mounting
Zero drift	Within ± 2%FS / week			Power supply voltage	100 to 240 V AC, 50 / 60 Hz, 50 VA
Span drift	Within ± 2%FS / week			Outside dimension	211 (H) × 218 (W) × 257 (D) mm
Interference from other gas components	Within ± 2%FS			Mass	Approximately 5 kg
Response time	Within 10 sec (90% response from the gas inlet)			Calibration gas	Zero gas : Dry N ₂ or dry air Span gas : Each sample gas having concentration 90 to 100% of its measuring range (recommended).
Analog output signal	4 to 20 mA or 0 to 1 V DC, or 0 to 100 mV or 0 to 10 mV DC Instantaneous value output (Concentration of each gas component measured) CP calculation output (Option)			[Measured gas conditions]	
Display	LCD with backlight (with auto OFF function) (Japanese or English by designation) Instantaneous value of each component, CP calculation result (option), parameter setting			Flow rate	0.5 L / min ± 0.2 L / min
Range switching	Manual switching by key operation, auto switching, external contact input switching (option)			Temperature	0°C to 40°C
Contact output	1a relay contact Instrument error (standard), each component range identification signal (option)			Pressure	5 kPa or lower
				Dust	0.3 μm or lower
				Mist	Not allowed.
				Moisture	Saturation at room temperature or lower (No condensation allowed.)
				Corrosive component	HCl : 1 ppm or less

Outline diagram (Unit : mm)

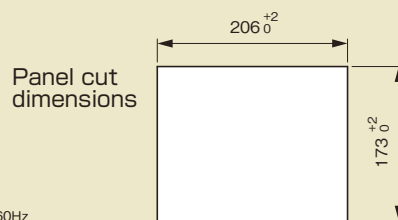
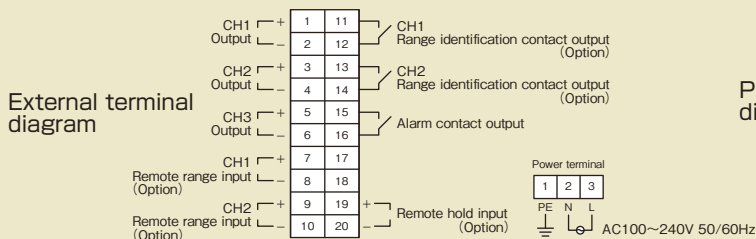
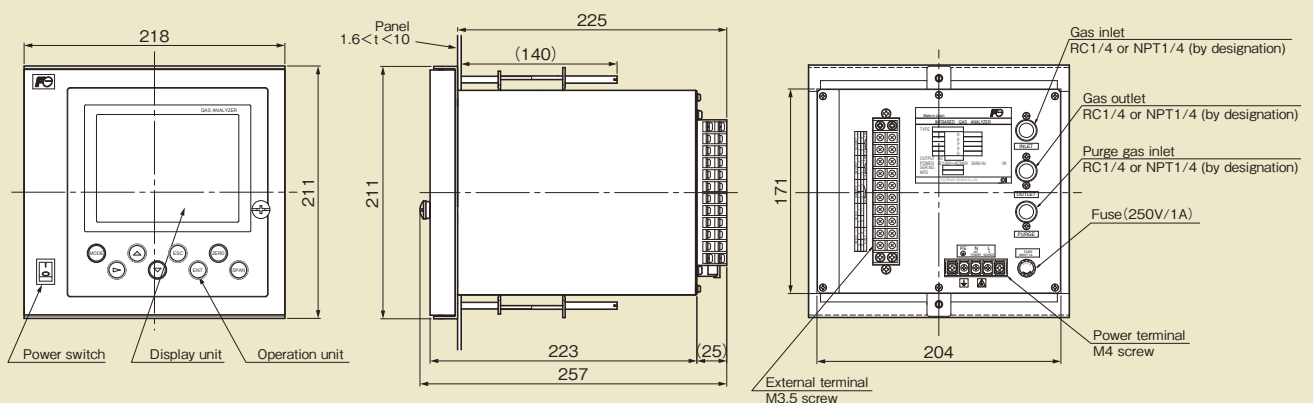

Correspondence table of the possible measuring ranges

Table 4 : Tow-component analyzer [CO₂ / CO]

1st component [CO ₂]		2nd component [CO]																			
1st range / 2nd range	Code	0~0.5 / 1%	0~1 / 2%	0~1 / 3%	0~2 / 3%	0~2 / 5%	0~3 / 5%	0~5 / 10%	0~10 / 20%	0~10 / 25%	0~20 / 25%	0~20 / 40%	0~20 / 50%	0~25 / 40%	0~25 / 50%	0~40 / 50%	0~40 / 70%	0~50 / 70%	0~50 / 100%	0~70 / 100%	0~100% / Without
		0~0.5 / 1%	HJ	○	○	○	○	○	○	○	○	○	○	○	○	○	○	○	○	○	○
0~1 / 2%	JK	○	○	○	○	○	○	○	○	○	○	○	○	○	○	○	○	○	○	○	○
0~1 / 3%	JQ	○	○	○	○	○	○	○	○	○	○	○	○	○	○	○	○	○	○	○	○
0~2 / 3%	KQ	○	○	○	○	○	○	○	○	○	○	○	○	○	○	○	○	○	○	○	○
0~2 / 5%	KL	○	○	○	○	○	○	○	○	○	○	○	○	○	○	○	○	○	○	○	○
0~3 / 5%	QL	○	○	○	○	○	○	○	○	○	○	○	○	○	○	○	○	○	○	○	○
0~5 / 10%	LM	-	○	○	○	○	○	○	○	○	○	○	○	○	○	○	○	○	○	○	○
0~10 / 20%	MN	-	-	-	○	○	○	○	○	○	○	○	○	○	○	○	○	○	○	○	○
0~10 / 25%	MV	-	-	-	○	○	○	○	○	○	○	○	○	○	○	○	○	○	○	○	○
0~20 / 25%	NV	-	-	-	○	○	○	○	○	○	○	○	○	○	○	○	○	○	○	○	○
0~20 / 40%	NW	-	-	-	○	○	○	○	○	○	○	○	○	○	○	○	○	○	○	○	○
0~20 / 50%	NP	-	-	-	○	○	○	○	○	○	○	○	○	○	○	○	○	○	○	○	○
0~25 / 40%	VW	-	-	-	○	○	○	○	○	○	○	○	○	○	○	○	○	○	○	○	○
0~25 / 50%	VP	-	-	-	○	○	○	○	○	○	○	○	○	○	○	○	○	○	○	○	○
0~40 / 50%	WP	-	-	-	○	○	○	○	○	○	○	○	○	○	○	○	○	○	○	○	○
0~40 / 70%	WX	-	-	-	○	○	○	○	○	○	○	○	○	○	○	○	○	○	○	○	○
0~50 / 70%	PX	-	-	-	○	○	○	○	○	○	○	○	○	○	○	○	○	○	○	○	○
0~50 / 100%	PR	-	-	-	○	○	○	○	○	○	○	○	○	○	○	○	○	○	○	○	○
0~70 / 100%	XR	-	-	-	○	○	○	○	○	○	○	○	○	○	○	○	○	○	○	○	○
0~100% / Without	RY	-	-	-	○	○	○	○	○	○	○	○	○	○	○	○	○	○	○	○	○

Table 5 : Tow-component analyzer [CO₂ / CH₄]

1st component [CO ₂]		2nd component [CH ₄]																
1st range / 2nd range	Code	0~2 / 3%	0~2 / 5%	0~3 / 5%	0~5 / 10%	0~10 / 20%	0~10 / 25%	0~20 / 25%	0~20 / 40%	0~20 / 50%	0~25 / 40%	0~25 / 50%	0~40 / 50%	0~40 / 70%	0~50 / 70%	0~50 / 100%	0~70 / 100%	0~100% / Without
		0~1 / 2%	JK	○	○	○	○	○	○	○	○	○	○	○	○	○	○	○
0~1 / 3%	JQ	○	○	○	○	○	○	○	○	○	○	○	○	○	○	○	○	○
0~2 / 3%	KQ	○	○	○	○	○	○	○	○	○	○	○	○	○	○	○	○	○
0~2 / 5%	KL	○	○	○	○	○	○	○	○	○	○	○	○	○	○	○	○	○
0~3 / 5%	QL	○	○	○	○	○	○	○	○	○	○	○	○	○	○	○	○	○
0~5 / 10%	LM	-	-	-	○	○	○	○	○	○	○	○	○	○	○	○	○	○
0~10 / 20%	MN	-	-	-	○	○	○	○	○	○	○	○	○	○	○	○	○	○
0~10 / 25%	MV	-	-	-	○	○	○	○	○	○	○	○	○	○	○	○	○	○
0~20 / 25%	NV	-	-	-	○	○	○	○	○	○	○	○	○	○	○	○	○	○
0~20 / 40%	NW	-	-	-	○	○	○	○	○	○	○	○	○	○	○	○	○	○
0~20 / 50%	NP	-	-	-	○	○	○	○	○	○	○	○	○	○	○	○	○	○
0~25 / 40%	VW	-	-	-	○	○	○	○	○	○	○	○	○	○	○	○	○	○
0~25 / 50%	VP	-	-	-	○	○	○	○	○	○	○	○	○	○	○	○	○	○
0~40 / 50%	WP	-	-	-	○	○	○	○	○	○	○	○	○	○	○	○	○	○
0~40 / 70%	WX	-	-	-	○	○	○	○	○	○	○	○	○	○	○	○	○	○
0~50 / 70%	PX	-	-	-	○	○	○	○	○	○	○	○	○	○	○	○	○	○
0~50 / 100%	PR	-	-	-	○	○	○	○	○	○	○	○	○	○	○	○	○	○
0~70 / 100%	XR	-	-	-	○	○	○	○	○	○	○	○	○	○	○	○	○	○
0~100% / Without	RY	-	-	-	○	○	○	○	○	○	○	○	○	○	○	○	○	○

Table 6 : Tow-component analyzer [CH₄ / CO]

1st component [CH ₄]		2nd component [CO]																		
1st range / 2nd range	Code	0~1 / 2%	0~1 / 3%	0~2 / 3%	0~2 / 5%	0~3 / 5%	0~5 / 10%	0~10 / 20%	0~10 / 25%	0~20 / 25%	0~20 / 40%	0~20 / 50%	0~25 / 40%	0~25 / 50%	0~40 / 50%	0~40 / 70%	0~50 / 70%	0~50 / 100%	0~70 / 100%	0~100% / Without
		0~1 / 2%	HJ	○	○	○	○	○	○	○	○	○	○	○	○	○	○	○	○	○
0~1 / 3%	JK	○	○	○	○	○	○	○	○	○	○	○	○	○	○	○	○	○	○	○
0~2 / 3%	JQ	○	○	○	○	○	○	○	○	○	○	○	○	○	○	○	○	○	○	○
0~2 / 5%	KQ	○	○	○	○	○	○	○	○	○	○	○	○	○	○	○	○	○	○	○
0~3 / 5%	KL	○	○	○	○	○	○	○	○	○	○	○	○	○	○	○	○	○	○	○
0~5 / 10%	QL	○	○	○	○	○	○	○	○	○	○	○	○	○	○	○	○	○	○	○
0~10 / 20%	LM	○	○	○	○	○	○	○	○	○	○	○	○	○	○	○	○	○	○	○
0~10 / 25%	MN	○	○	○	○	○	○	○	○	○	○	○	○	○	○	○	○	○	○	○
0~20 / 25%	MV	○	○	○	○	○	○	○	○	○	○	○	○	○	○	○	○	○	○	○
0~20 / 40%	NV	○	○	○	○	○	○	○	○	○	○	○	○	○	○	○	○	○	○	○
0~20 / 50%	NW	○	○	○	○	○	○	○	○	○	○	○	○	○	○	○	○	○	○	○
0~25 / 40%	NP	○	○	○	○	○	○	○	○	○	○	○	○	○	○	○	○	○	○	○
0~25 / 50%	VW	○	○	○	○	○	○	○	○	○	○	○	○	○	○	○	○	○	○	○
0~40 / 50%	VP	○	○	○	○	○	○	○	○	○	○	○	○	○	○	○	○	○	○	○
0~40 / 70%	WP	-	-	○	○	○	○	○	○	○	○	○	○	○	○	○	○	○	○	○
0~50 / 70%	WX	-	-	○	○	○	○	○	○	○	○	○	○	○	○	○	○	○	○	○
0~50 / 100%	PX	-	-	○	○	○	○	○	○	○	○	○	○	○	○	○	○	○	○	○
0~70 / 100%	PR	-	-	○	○	○	○	○	○	○	○	○	○	○	○	○	○	○	○	○
0~100% / Without	XR	-	-	○	○	○	○	○	○	○	○	○	○	○	○	○	○	○	○	○

Fuji Electric Systems Co., Ltd.

Head Office
 Gate City Ohsaki, East Tower,
 11-2, Osaki 1-chome, Shinagawa-ku, Tokyo 141-0032, Japan
<http://www.fesys.co.jp/eng>

**Instrumentation Div.
 International Sales Dept.**
 No.1, Fuji-machi, Hino-city, Tokyo, 191-8502 Japan
 Phone : 81-42-585-6201,6202
 Fax : 81-42-585-6187
<http://www.fic-net.jp/eng>