

REPLACE CASE

DATA SHEET

PDZE

This replacing case is used in a situation where compact controller E series and F series are replaced with compact controller M series.

This product is convenient when wiring from the duct is difficult. It results in substantial labor savings.

SPECIFICATIONS

1. Types of Compact Controller M series models that may be built-in

Continuous output type controller,

Model : PDA211A $\begin{matrix} 1 \\ 2 \end{matrix}$ -B* $\begin{matrix} Y \\ D \\ M \end{matrix}$ *

Step output type controller,

Model : PDC211A2-B*Y $\begin{matrix} Y \\ M \end{matrix}$ *

Continuous output type manual loader,

Model : PDB111A2-BA $\begin{matrix} Y \\ D \\ M \end{matrix}$ *

Continuous output type setter,

Model : PDF111A2-BRY $\begin{matrix} Y \\ M \end{matrix}$ *

Continuous output type ratio setter,

Model : PDG111A $\begin{matrix} 1 \\ 2 \end{matrix}$ -BRY $\begin{matrix} Y \\ M \end{matrix}$ *

Electronic indicator,

Model : PDJ111A2-BYY $\begin{matrix} Y \\ M \end{matrix}$ *

2. Number of input/output points

The specification such as the influence of the accuracy and environment corresponds to the specification for Compact Controller M series.

2-1 Analog inputs

- Points : MAX. 7 points
- Kind of input : Voltage input
- Input range : 1 to 5V DC

Note: The opening input of an step output type controller is applicable to voltage input specification only.

2-2 Analog outputs

1) Control output or manipulated output

- Points : 1 point
- Output signal : 4 to 20mA DC

Note: This function is valid only with a continuous output type controller or a continuous output type manual loader.

2) Auxiliary analog output

- Points : 5 points
- Output signal : 1 to 5V DC

2-3 Digital inputs /outputs

1) Auxiliary digital input signals

- Points : 9 points



2) Control output signal (pulse width output "PO")

- Points : 1 set (2 points)

Note: This function is valid only with an step output type controller.

Important: Externally cross-connect the control outputs to prevent the increasing pulse and the decreasing pulse from being turned on at the same time.

3) Fault output signal ("FLT")

- Points : 1 point

4) Auxiliary digital output signal

- Points : 10 points (with a continuous output type instrument or an electronic type indicator)
- 8 points (with an step output type controller)

3. Operation ambient specifications

• Dielectric strength

- : 500V AC × 1 minute (Between power terminals VP, PC and ground terminal)
- 500V AC × 1 minute (Between signal terminals and ground terminal)

• Insulation resistance

- : 500V DC, 50MΩ or more

• Grounding

- : D-class grounding

• Insulation location

- : at room

• Ambient temperature

- : 0 to 50°C (but, 40°C or less when multi-

row/tier mounting)

• Temperature change ratio

- : 10°C/H or less

• Ambient humidity

- : 5 to 90%RH (not condensed)

• Continuous vibration

- : Not specified. Provide a support in the panel, which should be fixed to the case for vibration resistance.

• Altitude

- : 2000m or lower above the sea level

- **Transport and storage**
 - : Temperature ; -20 to 70°C
 - Temperature change ratio ; 10°C/H or less
 - Humidity ; 5 to 95%RH (not condensed)
 - Shock ; Not specified

- **Mounting angle** : Allowable within backward angle 0 to 45, not allowable down ward

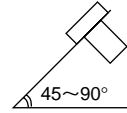

4. Structure

- **Case** : Stainless steel
- **Finish color of case** : Munsell N1.5
- **Protection** : Not protected
- **External dimensions** : 70.5 (W) × 177 (H) × 407 (D) mm
Depth from front panel (including terminal cover)
- **Mass** : Approx. 1.5kg (without CC-M main unit)
- **Mounting method** : Flash on indoor panel

5. Type designation

- PDZE1002 (continuous output type controller, continuous output type instrument and electronic type indicator)
- PDZE2002 (step output type controller: Corresponds to PDC only)

6. Scope of supply

- Replacing case
- Fixture × 1, bolt × 1, mounting hardware × 1
- Instruction manual (CC-M main unit is not included. It is to be ordered separately.)
- (Supporting hardware is not included. Kindly use existing hardware.)

OUTLINE DIAGRAM (Unit : mm)

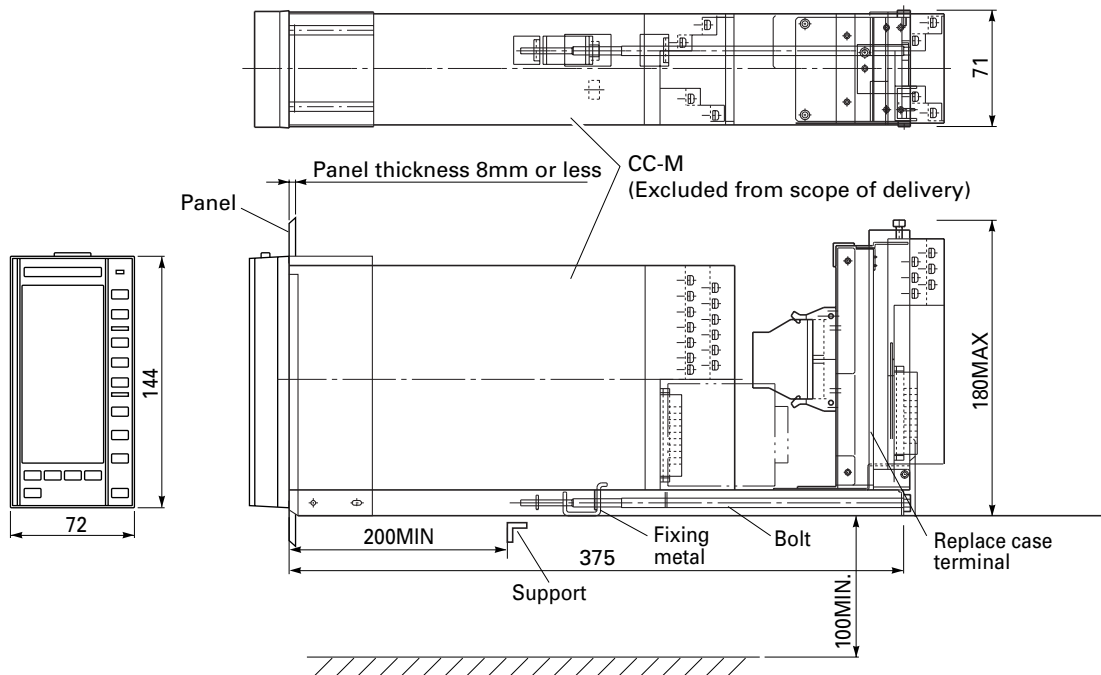

PANEL CUTOUT

MOUNTING ONE UNIT

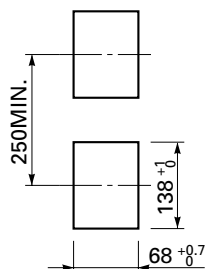

MOUNTING n UNITS

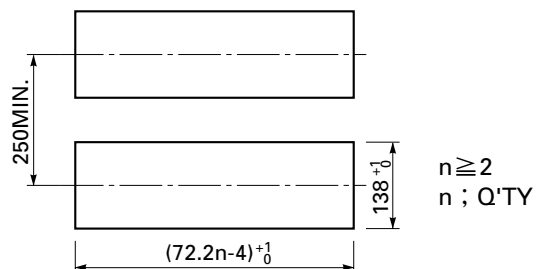

External connection diagram

PDZE1002 Screw terminal area

(Continuous output type instrument)

(Unused)	11	—	31	—	(Unused)
(DI)	12	INT	32	—	(Unused)
(DI)	13	SMV	33	FLT	(DO)

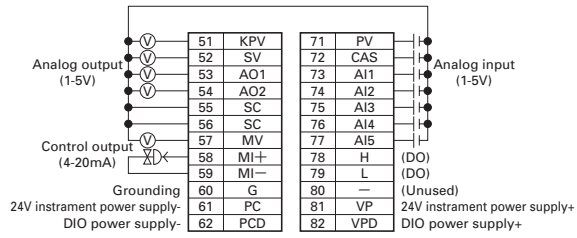

Note : Continuous output type setter, ratio setter or electronic indicator is to be connected to this terminal. Provided, however, that control output terminal cannot be used.

Multi connector area

(Continuous output type controller / operator)

23	H	13	DI5	1	—
24	L	14	PV-TRK	2	—
25	—	15	R-ACK	3	PCD
26	—	16	DI1	4	AO1
27	—	17	DI2	5	AO2
28	DO1	18	DI3	6	AI1
29	DO2	19	DI4	7	AI2
30	DO3	20	—	8	AI3
31	DO4	21	DO8	9	AI4
32	DO5	22	MV	10	AI5
33	DO6			11	SC
34	DO7			12	VPD

Note : Continuous output type setter, ratio setter or electronic indicator is to be connected to this terminal.

PDZE2002 Screw terminal area

(Step output type controller)

(Unused)	11	—	31	—	(Unused)
(DI)	12	INT	32	—	(Unused)
(DI)	13	SMV	33	FLT	(DO)

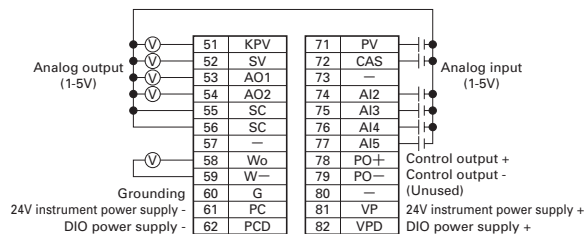

Multi connector area

(Step output type controller)

23	H	13	DI5	1	—
24	L	14	PV-TRK	2	—
25	—	15	R-ACK	3	PCD
26	—	16	DI1	4	AO1
27	—	17	DI2	5	AO2
28	—	18	DI3	6	—
29	—	19	DI4	7	AI2
30	DO3	20	—	8	AI3
31	DO4	21	DO8	9	AI4
32	DO5	22	MV	10	AI5
33	DO6			11	SC
34	DO7			12	VPD

Note : Step output type controller is to be connected to this terminal

Note: Externally cross-connect the control outputs.

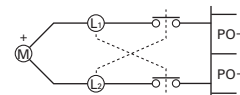

Note: Open input is 1 to 5 V DC. In the case of resistance input (potentiometer input), apply voltage with potentiometer input converters placed before and after.

Isolated blocks

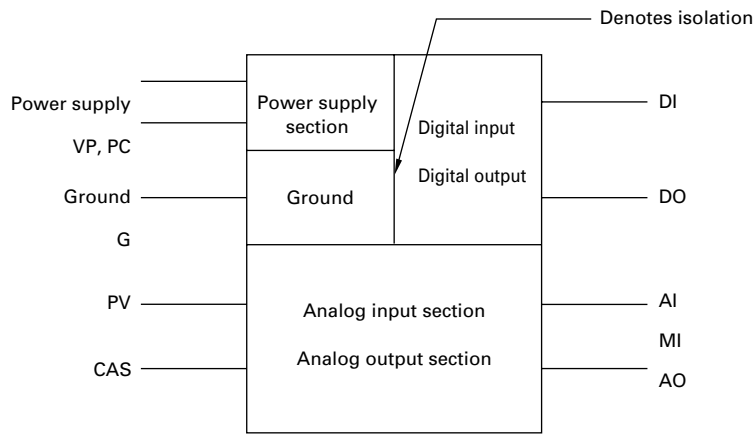

List of terminal numbers and terminal names corresponding to the replacing case and CC-M (Wiring should be performed so as to coincide the terminal name of the replaced type with that of the replacing case).

[PDZE1002]

CC-M (PDA)		Replace Case Terminal		Controller (type PMK-3/CC-F)		Controller (type PMA-3/CC-E)		Controller (type PNA/CC-S)		Manual loader (PMB)		Setter (PMF)		Ratio setter (PMG)		Remarks
Terminal No.	Terminal name	Terminal No.	Terminal name	Terminal No.	Terminal name	Terminal No.	Terminal name	Terminal No.	Terminal name	Terminal No.	Terminal name	Terminal No.	Terminal name	Terminal No.	Terminal name	Terminal name
11	I+1	71	PV	71	PV	71	PV	11	I+	31	PV	31	PV	31	PV	Analog input
14	I+2	72	CAS	72	CAS	72	CAS	71	CAS	—	—	33	CAS	33	CAS	Analog input
31	FLT	33	FLT	33	FLT	33	FLT	34	FLT	—	—	—	—	—	—	Digital output
55	AO5	57, M22	MV	57, M22	MV	76	MV	54	MV	35	MV	—	—	35	SO	Analog output
52, M6	AO2	54, M5	AO2	54, M5	AO2	—	—	—	—	—	—	—	—	—	—	Analog output
53	AO3	51	KPV	51	KPV	51	KPV	51	KPV	—	—	—	—	—	—	Analog output
54	AO4	52	SV	52	SV	52	SV	52	SV	—	—	34	SV	34	SV	Analog output
51, M5	AO1	53, M4	AO1	53, M4	AO1	53	AO1	53	AO1	—	—	—	—	—	—	Analog output
56, 57, M11	SC	55, 56, M11	SC	55, 56, M11	SC	54, 55	SC	55, 76	SC	32	SC	32	SC	32	SC	Signal common
62, M12, M34	PCD	62, M3	PCD	62, M3	PCD	62	PCD	61	PCD	16	PC Note1	16	PC Note1	16	PC Note1	Digital Common
63	G	60	G	60	G	60	G	62	G	G	G	G	G	G	G	Grounding
64	N/—	61	PC	61	PC	61	PC	60	PC	16	PC Note1	16	PC Note1	16	PC Note1	Instrument power supply -
71, M7	AI1	73, M6	AI1	73, M6	AI1	73	AI1	72	AI1	33	AI1	33	AI1	33	AI1	Analog input
72, M8	AI2	74, M7	AI2	74, M7	AI2	74	AI2	73	AI2	—	—	—	—	—	—	Analog input
73, M9	AI3	75, M8	AI3	75, M8	AI3	75	AI3	74	AI3	—	—	—	—	—	—	Analog input
74, M10	AI4	76, M9	AI4	76, M9	AI4	—	—	—	—	—	—	—	—	—	—	Analog input
75	AI5	77, M10	AI5	77, M10	AI5	—	—	—	—	—	—	—	—	—	—	Analog input
77	MI+1	58	MI+	58	MI+	56	MI+	56	MI+	36	MI+	—	—	—	—	Control output
78	MI-1	59	MI-	59	MI-	57	MI-	57	MI-	37	MI-	—	—	—	—	Control output
82, M33	VPD	82, M12	VPD	82, M12	VPD	82	VPD	82	VPD	15	VP Note1	15	VP Note1	15	VP Note1	Digital power supply +
83	L/+	81	VP	81	VP	81	VP	81	VP	15	VP Note1	15	VP Note1	15	VP Note1	Instrument power supply +
M13	DI1	M16	DI1	M16	DI1	31	PI+	32	PI+	—	—	12	PI+	12	PI+	Digital input
M14	DI2	M17	DI2	M17	DI2	32	PI-	33	PI-	—	—	13	PI-	13	PI-	Digital input
M15	DI3	M18	DI3	M18	DI3	—	—	—	—	—	—	—	—	—	—	Digital input
M16	DI4	M19	DI4	M19	DI4	—	—	—	—	—	—	—	—	—	—	Digital input
M17	DI5	M13	DI5	M13	DI5	80	EX-MC (DI2)	79	EX-MC (DI2)	—	—	—	—	—	—	Digital input
M19	DI7	M14	PV-TRK	M14	PV-TRK	79	PV-TRK	80	PV-TRK (DI1)	—	—	—	—	—	—	Digital input
M20	DI8	M15	R-ACK	M15	R-ACK	78	R-ACK	78	R-ACK (DI3)	—	—	—	—	—	—	Digital input
M21	DI9	12	INT	—	—	—	—	—	—	—	—	—	—	—	—	Digital input
M22	DI10	13	SMV	13	SMV	13	SMV	15	SMV	12	MC	—	—	—	—	Digital input
M23	DO1	M28	DO1	M28	DO1	—	—	—	—	—	—	—	—	—	—	Digital output
M24	DO2	M29	DO2	M29	DO2	—	—	—	—	—	—	—	—	—	—	Digital output
M25	DO3	M30	DO3	M30	DO3	—	—	—	—	—	—	—	—	—	—	Digital output
M26	DO4	M31	DO4	M31	DO4	—	—	—	—	—	—	—	—	—	—	Digital output
M27	DO5	M32	DO5	M32	DO5	—	—	—	—	—	—	—	—	—	—	Digital output
M28	DO6	M33	DO6	M33	DO6	11	M	13	M	11	M	11	L	11	L	Digital output
M29	DO7	M34	DO7	M34	DO7	12	LS	14	LS (DO1)	—	—	—	—	—	—	Digital output
M30	DO8	M21	DO8	M21	DO8	77	R-REQ	77	R-REQ	—	—	—	—	—	—	Digital output
M31	DO9	M23, 78	H	M23, 78	H	58	H	58	H	—	—	—	—	—	—	Digital output
M32	DO10	M24, 79	L	M24, 79	L	59	L	59	L	—	—	—	—	—	—	Digital output

Note2

Replaced Instruments

Note: Terminal numbers on left of each model
Note: Terminal names on right of each model

Note1: Connect PC and VP wires to PC and PCD, and VP and VPD, respectively, of the replace case.

Note2: In case of soft connection (wafer connection) with CC-M, confirm the replace case and CC-M terminals.

Common: Screw terminals "M", "PI+", "PI-", "PDI" cannot be used.
(11) (31) (32) (80)

Multi-connectors "R-REQ", "LS", "NOT-A", "C-ENBL", "HM" cannot be used.
The replace case terminal is not provided with a connector for communication.

List of terminal numbers and terminal names corresponding to the replacing case and CC-M (Wiring should be performed so as to coincide the terminal name of the replaced type with that of the replacing case).

[PDZE2002]

CC-M(PDC)		Replace Case Terminal		Controller (type PML-3/CC-F)		Controller (type PMC-3/CC-E)		Controller (type PNC/CC-S)		Manual loader (PMD)		Manual loader (PND)		—		Remarks
Terminal No.	Terminal name	Terminal No.	Terminal name	Terminal No.	Terminal name	Terminal No.	Terminal name	Terminal No.	Terminal name	Terminal No.	Terminal name	Terminal No.	Terminal name	Terminal No.	Terminal name	Terminal name
11	I+1	71	PV	71	PV	71	PV	11	I+	31	PV	11	I+	—	—	Analog input
14	I+2	72	CAS	72	CAS	72	CAS	71	CAS	—	—	—	—	—	—	Analog input
31	FLT	33	FLT	33	FLT	33	FLT	34	FLT	—	—	34	FLT	—	—	Digital output
55	AO5	M22	MV	M22	MV	—	—	—	—	—	—	—	—	—	—	Analog output
52, M6	AO2	54, M5	AO2	54, M5	AO2	—	—	—	—	—	—	—	—	—	—	Analog output
53	AO3	51	KPV	51	KPV	51	KPV	51	KPV	—	—	51	KPV	—	—	Analog output
54	AO4	52	SV	52	SV	52	SV	52	SV	—	—	—	—	—	—	Analog output
51, M5	AO1	53, M4	AO1	53, M4	AO1	53	AO1	53	AO1	—	—	—	—	—	—	Analog output
56, 57, M11	SC	55, 56, M11	SC	55, 56, M11	SC	54, 55	SC	55, 76	SC	32	SC	55, 76	SC	—	—	Signal common
62, M12, M34	PCD	62, M3	PCD	62, M3	PCD	62	PCD	61	PCD	16	PC Note1	61	PCD	—	—	Digital Common
63	G	60	G	60	G	60	G	62	G	G	G	62	G	—	—	Grounding
64	N/—	61	PC	61	PC	61	PC	60	PC	16	PC Note1	60	PC	—	—	Instrument power supply +
71, M7	Ai1	58	Wo	58	Wo	75	Wo	54	Wo	33	W+ Note5	54	Wo	—	—	Analog input
56, 57, M11	SC	59	W—	59	W—	76	W—	75	W—	35	W—	75	W—	—	—	Signal common
72, M8	Ai2	74, M7	Ai2	74, M7	Ai2	—	—	73	Ai2	—	—	—	—	—	—	Analog input
73, M9	Ai3	75, M8	Ai3	75, M8	Ai3	—	—	—	—	—	—	—	—	—	—	Analog input
74, M10	Ai4	76, M9	Ai4	76, M9	Ai4	—	—	—	—	—	—	—	—	—	—	Analog input
75	Ai5	77, M10	Ai5	77, M10	Ai5	—	—	—	—	—	—	—	—	—	—	Analog input
M23	DO1	78	PO+	78	PO+	56	PO+	56	PO+	36	PO+	56	PO+	—	—	Control output
M24	DO2	79	PO—	79	PO—	57	PO—	57	PO—	37	PO—	57	PO—	—	—	Control output
82, M33	VPD	82, M12	VPD	82, M12	VPD	82	VPD	82	VPD	15	VP Note1	82	VPD	—	—	Digital power supply +
83	L/+	81	VP	81	VP	81	VP	81	VP	15	VP Note1	81	VP	—	—	Instrument power supply +
M13	DI1	M16	DI1	M16	DI1	31	PI+	32	PI+	12	PI+	32	PI+	—	—	Digital input
M14	DI2	M17	DI2	M17	DI2	32	PI—	33	PI—	13	PI—	33	PI—	—	—	Digital input
M15	DI3	M18	DI3	M18	DI3	—	—	—	—	—	—	—	—	—	—	Digital input
M16	DI4	M19	DI4	M19	DI4	—	—	—	—	—	—	—	—	—	—	Digital input
M17	DI5	M13	DI5	M13	DI5	80	EX-MC (DI2)	79	(DI2)	—	—	—	—	—	—	Digital input
M19	DI7	M14	PV-TRK	M14	PV-TRK	79	PV-TRK (DI1)	80	PV-TRK (DI1)	—	—	—	—	—	—	Digital input
M20	DI8	M15	R-ACK	M15	R-ACK	78	R-ACK	78	R-ACK (DI3)	—	—	—	—	—	—	Digital input
M21	DI9	12	INT	12	INT	—	—	—	—	—	—	—	—	—	—	Digital input
M22	DI10	13	SMV	13	SMV	13	SMV	15	SMV	12	MC	15	SMV	—	—	Digital input
M23	DO1	M28	—	M28	DO1	—	—	—	—	—	—	—	—	—	—	Digital output
M24	DO2	M29	—	M29	DO2	—	—	—	—	—	—	—	—	—	—	Digital output
M25	DO3	M30	DO3	M30	DO3	—	—	—	—	—	—	—	—	—	—	Digital output
M26	DO4	M31	DO4	M31	DO4	—	—	—	—	—	—	—	—	—	—	Digital output
M27	DO5	M32	DO5	M32	DO5	—	—	—	—	—	—	—	—	—	—	Digital output
M28	DO6	M33	DO6	M33	DO6	11	M	13	M	—	—	13	M	—	—	Digital output
M29	DO7	M34	DO7	M34	DO7	12	LS	14	LS (DO1)	—	—	—	—	—	—	Digital output
M30	DO8	M21	DO8	M21	DO8	77	R-REQ	77	R-REQ (DO2)	—	—	—	—	—	—	Digital output
M31	DO9	M23	H	M23	H	58	H	58	H	—	—	58	H	—	—	Digital output
M32	DO10	M24	L	M24	L	59	L	59	L	—	—	59	L	—	—	Digital output

Note2,3,4

Replaced instruments

Note: Terminal numbers on left of each model
Note: Terminal names on right of each model

Note1: Connect PC and VP wires to PC and PCD, and VP and VPD, respectively, of the replace case.

Note2: In case of soft connection (wafer connection) with CC-M, confirm the replace case and CC-M terminals.

Note3: Ai1 terminal on replace case terminal is not connected in the interior (it should not be used).

Note4: Terminals DO1 and DO2 (multi-connector terminals) on replace case terminal have not been connected internally, and cannot be used.

Note5: PMD is of different connecting terminal names. Be careful. Furthermore, terminal names of PML and PMC are also different with I type. Be careful.

Common: Screw terminals "M", "PI+", "PI-", "W+", "PDI" cannot be used. (11) (31) (32) (57) (80)

Multi-connectors "R-REQ", "LS", "NOT-A", "DO1", "DO2", "C-ENBL", "AI1" cannot be used.

The replace case terminal is not provided with a connector for communication.

⚠ Caution on Safety

*Before using this product, be sure to read its instruction manual in advance.

Fuji Electric Systems Co., Ltd.

Head Office

Gate City Ohsaki, East Tower, 11-2, Osaki 1-chome, Shinagawa-ku, Tokyo 141-0032, Japan

http://www.fesys.co.jp/eng

Instrumentation Div.

International Sales Dept.

No.1, Fuji-machi, Hino-city, Tokyo, 191-8502 Japan

Phone: 81-42-585-6201, 6202 Fax: 81-42-585-6187

http://www.fic-net.jp/eng

Information in this catalog is subject to change without notice.

Printed in Japan