

Digital Controller **COMPACT CONTROLLER M [CC-M]** (FIXED FUNCTION/CONTINUOUS OUTPUT TYPE)

DATA SHEET

PDA1

The Compact Controller M (fixed function/continuous output type) is a single-loop process controller.

Receiving 1 to 5V DC signals as well as those from thermocouples and resistance bulbs as input signals, it performs advanced controls such as PID control, square root extraction, non-linear control, and feed forward control.



FEATURES

1. Single-loop controller with control output

The controller has a single-loop control function.

2. High visibility ensured by color graphic display

A color LCD is adopted for clear graphic displays such as bar graph and trend displays.

3. Networking (option)

Communication can be carried out over our PLC-link (T-link) or Modbus (RS485) network.

4. Backup (option)

In the event of a failure of the main unit, the built-in backup operation device takes over the operation, thus preventing adverse effect on the system.

5. Memory card (option)

The data such as process input data and control output data can be saved in memory cards.

FUNCTIONAL DIAGRAM

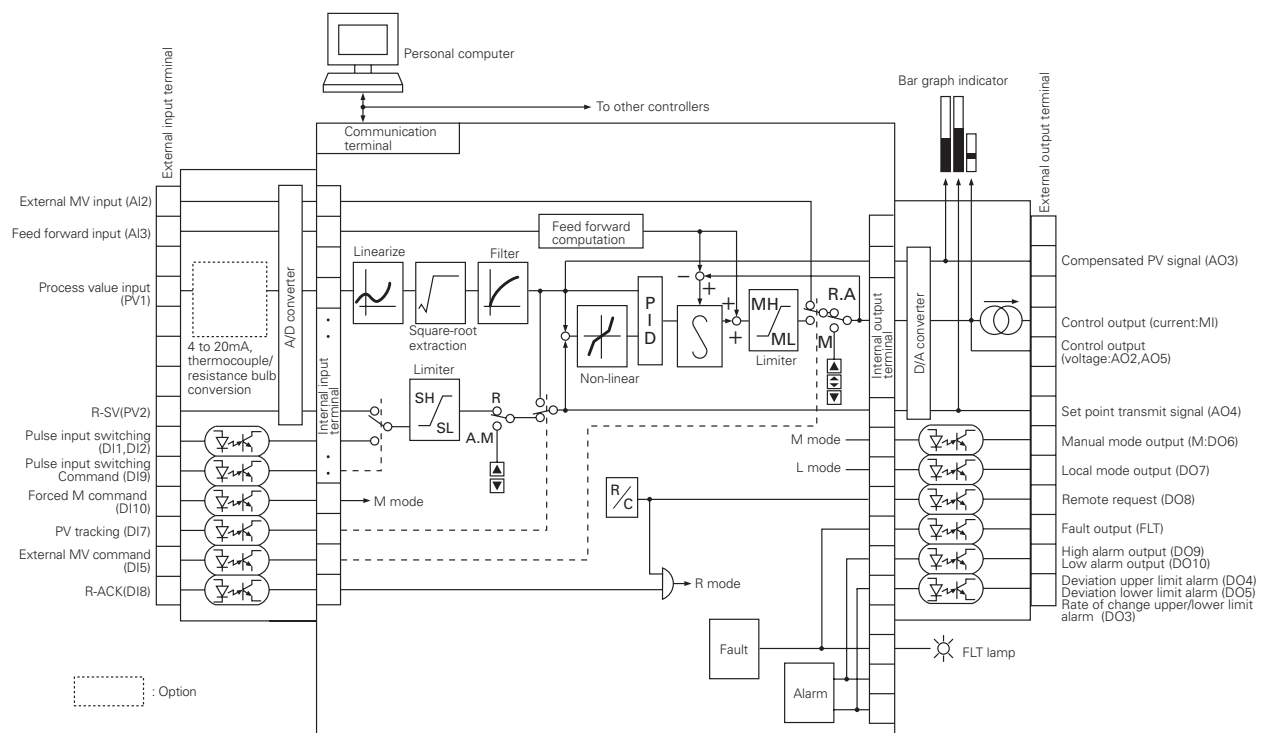

SPECIFICATIONS

1. Control Functions

(1) PID control

- Number of loops and PID : 1 loop (1 control output / 1PID)
- Proportional band (P) : 1.0 to 3276.7%, set at 3000.0% for delivery
- Integration time (I) : 0.1 to 3276.7 s, set at 3000.0 s for delivery
- Derivative time (D) : 0.0 to 900.0 s, set at 0.0 s for delivery

(2) Computation cycle

: 100 ms

(3) Alarm function

- Kinds : Each high/low of PV, SV and MV, PV change rate alarm, MV change rate alarm, high/low deviations.

2. Input Signals

Performance under reference condition (23±2°C, 55±10%RH, 100 V to 240 V AC, 50/60Hz power supply frequency or 24 V DC power supply voltage, free from vibration and the effect of external noise)

2-1 Analog input signal

- Number of inputs : 4 (points used)
- Input signal types :
 - DC voltage, DC current, thermocouple (option), resistance bulb (option)
 - One thermocouple inputs or one resistance bulb inputs are selectable.
- (1) DC voltage / DC current
 - Input range: Selectable among 0 to 5 V DC, 1 to 5 V DC and 0 to 10 V DC
Initial set before delivery : 1 to 5 V DC
 - Input accuracy: ±0.1% of input span±1 digit
 - Scaling (Engineering data conversion) :
Settable within a range from -32767 to 32767
4, 3, 2, 1 or 0 digit below decimal point is selectable.
Initial set before delivery : 0.00% to 100.00%
 - Engineering unit: Settable in up to 8 characters
Usable characters: Alphabets numerals, symbols such as +, -, *, etc.
 - Input accuracy guarantee range: -5% to 105% of input range (minus input excluded).
 - Maximum continuous permissible voltage: ±35 V
 - Input resistance: 1 MΩ or more
 - Influence by ambient temperature: ±0.1% FS/10°C or less.
 - Influence by power supply fluctuation: ±0.1% FS or less.
 - Isolation : Non-isolated from internal circuit.

- In case of current input:
Shunt resistor need to be connected to the analog input terminal.
(250 Ω shunt resistor is optional item)

(2) Thermocouple (option)

- Types and measurable ranges:
* See Table 1.
- Input accuracy: ±0.2% FS ±1 digit
[Note]B type: ±5% between 0 to 400°C
S and R type: ±1% between 0 to 500°C
All type of TC: ±5% under -100°C
- Reference junction compensation error: ±1.0°C (provided measurable range is -50°C and higher)
[Note]Reference junction compensation resistor is connected at external input terminal in case of thermocouple input is ordered.
- Input accuracy guarantee range: -5% to 105% of input range.
- Input resistance: 1 MΩ or more
- Allowable signal source resistance: 100 Ω or less (Zener barrier connection unallowable)
- Influence by signal source resistance: About 0.25 μV/Ω
- Influence by ambient temperature: ±0.2% FS/10°C ±1°C or less.
- Influence by power supply fluctuation: ±0.2% FS ±1°C or less
- Burnout detection: Provided
- Isolation: Isolated from internal circuit.

(3) Resistance bulb (option)

- Types and measurable ranges:
* See Table 1.
- Input accuracy: ±0.2% FS ±1 digit
- Input accuracy guarantee range: -5% to 105% of input range
- Allowable wiring resistance: 10Ω or less per wire, provided wiring resistance must be equal among 3 wires (Zener barrier connection unallowable)
- Influence by ambient temperature: ±0.2% FS/10°C or less.
- Influence by power supply fluctuation: ±0.2% FS or less
- Burnout detection: Provided
- Isolation: Isolated from internal circuit.

[Note] FS: full span.

- Sampling period : 100 ms

2-2 Digital input signal

- Number of inputs : 7 inputs
- Electrical specifications : No-voltage contact or transistor contact ON/0 V, OFF/24 V, ON current/about 8 mA
Isolated from the internal circuit by photocoupler. Not isolated between each digital input and output.
- Contact rating : 30 V DC, 10 mA or more

- **Signal judgment**
 - : No-voltage contact
 - Contact resistance;
 - 200 Ω or less at ON,
 - 100 kΩ or more at OFF
 - : Transistor contact
 - 1V max at ON.,
 - leakage current 100μA max. at OFF

3. Output Signals

Performance under reference condition (23±2°C, 55±10%RH, 100 V to 240 V AC, 50/60Hz power supply frequency or 24 V DC power supply voltage, free from vibration and the effect of external noise)

3-1 Analog output signal

(1) Control output

- **Number of outputs** : 1
- **Output signal** : 4 to 20 mA DC
- **Output accuracy** : ±0.2% FS
- **Load resistance** : 600 Ω or less
- **Output accuracy guarantee range** : 2 to 22 mA DC
- **Influence by ambient temperature** : ±0.2% FS/10°C or less
- **Influence by power supply fluctuation** : ±0.2% FS or less
- **Isolation** : Non-isolated from internal circuit

(2) Auxiliary analog output

- **Number of outputs:** : 4 (points used)
- **Types of signal:** Selectable among 0 to 5 V DC, 1 to 5 V DC and 0 to 10 V DC
Initial set before delivery: 1 to 5 V DC
- **Output accuracy** : ±0.1% FS
- **Load resistance** : 15 kΩ or more
- **Output guarantee range** : 1 to 5 VDC : -12.5% to 112.5%
: 0 to 5 VDC : 0% to 112.5%
: 0 to 10VDC : 0% to 105%
- **Influence by power supply fluctuation** : ±0.1% FS or less
- **Isolation** : Non-isolated from internal circuit

3-2 Digital output signal

- **Number of outputs** : 8 (points used)
- **Electrical specifications** : Transistor open collector
1 V max. at ON, 10 μA max at OFF.
Isolated from the internal circuit by photocoupler. Not isolated between each digital input and output.
- **Output rating** : 30 V DC, 100 mA max. (resistive load)

3-3 Fault output signal (terminal symbol FLT)

- **Number of outputs** : 1 output
- **Electrical specifications**

: Transistor open collector
1 V max. at ON, 10 μA max at OFF.
Isolated from the internal circuit by photocoupler. Not isolated between each digital input and output.

- **Output rating** : 30 V DC, 100 mA max. (resistive load)

4. Display

- **Display unit** : 16 Colors graphic liquid crystal display, with CFL back light and contrast adjust function.
- **Contents of display** : Menu
: Loop panel (1 loops)
Bar graph display, digital display, etc.
: Tuning screen
: Trend screen
: Alarm and alarm historical screen
: Analog input/output and digital input/output indication screen
: Parameter setting screen

5. Setting and Operation

(1) Set point setting method

- **Setting key** : Up key/down key
- **Setting speed** : About 40 s/FS
- **Setting resolution** : 0.05% FS/each key press

(2) Control output operation method

- **Operation key** : Up key, down key and high-speed key
- **Operation speed** : About 40 s/FS (usual),
about 8 s/FS (high speed)

(3) Operation mode

- **Kinds of operation mode** : C (or R), A, M and HM
- [Note] C : Cascade mode (operation according to remote set point)
R : Remote mode (operation according to remote set point)
A : Auto mode (operation according to the local set point)
M : Manual mode (control output to be manually operated by operator)
HM : Hard manual mode (the mode in which operation is performed with a backup operating device)
- [Remark] C and R have different nameplates, while operation is the same.

• Setting method

: Selectable from the followings by specifying the code symbols.
C - A - M
A - M
R - A - M

- **Changeover** : Balance bumpless changeover from Auto to Remote and from Auto to Cascade
Balanceless bumpless in other changeover

[Note] Balance bumpless changeover is a method where each setting value needs to be balanced by operator himself at the time of changeover. Balanceless bumpless changeover is a method where each setting value is automatically balanced by the controller at the time of changeover.

(4) Security

- **Method** : Setting of a password
- **Password** : Settable in 4 numerals (within 0000 to ffff)
Initial set before delivery: 0000
- **Contents of security**
: Inhibition of parameter setting

(5) Other setting items

- **Tag name** : Settable in up to 8 characters
Usable characters; alphabets, numerals, symbols such as +, -, *, etc.

6. Power Supply

- **Voltage rating** : 100 V to 240 V AC/24 V DC [According to Code Symbols]
- **Allowable range**
: 85 V to 264 V AC/20 V to 30 V DC [According to Code Symbols]
- **Frequency** : 47 to 63 Hz
- **Power consumption**
: 60 VA or less (100 V to 240 V AC)
: 30 W or less (24 V DC)
[According to Code Symbols]
- **Power supply output voltage (terminal symbol VP and PC)**
: 20V to 30V DC, max. 40mA

7. General performance and characteristics

- **Insulation resistance**
: 500 V DC, 50 MΩ or more.
- **Dielectric strength**
: 2,000 V AC for 1 minute between power terminal and ground terminal in case of 100 V to 240 V AC power supply
: 500 V AC for 1 minute between power terminal and ground terminal in case of 24 V DC power supply.
: 500 V AC for 1 minute between signal communication terminals and ground terminal
- **Rush current** : 60 A or less. (100 V AC to 240 V AC power supply)
- **Clock** : Set and display year, month, day, hour, minute, second
accuracy : ±100 ppm (deviation per month: about 4 min) except of time lag shorter than 1 s / power ON / OFF action.
- **Memory backup**
: Protection by lithium battery.
(expected battery life is about 2 years under room temperature)
Parameter and program are stored non-volatile memory.

8. Operating and storage conditions

- **Location** : Indoor
- **Operating temperature**
: 0 to 50°C
: 0 to 40°C in case of multiple mounting
(**Temperature change rate**
: Max. 10°C / h)
- **Transport and storage temperature**
: -20 to 70°C
(**Temperature change rate**
: Max. 20°C / h)

- **Operating humidity**
: 5 to 90% RH, condensation unallowable
- **Transport and storage humidity**
: 5 to 95% RH, condensation unallowable
- **Operating continuous vibration**
: 4.9 m/s² or less
- **Transport and storage shock**
: Fall of 60cm max. in packed status

9. Power Failure and restart Function

- **Permissible duration of momentary power failure**
: 20 ms at 90V AC (100 V to 240 V AC only)
In the case of 24V DC, it is recommended to avoid power failure problem that system power supply unit with permissible duration of momentary power failure of 20ms or more (PXJ, for example) is used.
- **Behavior at power failure detection**
: Control stops at detection of power failure.
- **Power recovery mode**
: Selectable initial start and continuous start

10. Self-Diagnosis

- **Control and computation circuit failure**
: Monitoring with watchdog timer
- **Input signal failure**
: Voltage/current input
Monitoring of range over
: Thermocouple and resistance bulb
Monitoring of disconnection
- **Behavior at failure**
: FLT is indicated, FLT lamp lights, FLT output signal turns on, control stops and control output is held.

11. Structure

- **Enclosure** : Plastic (material: PC-ABS)
- **Finish color** : Front frame and enclosure both gray
- **Flame resistance**
: UL94V-0
- **Protection** : Front face; IP54 (display unit and operation key)
- **External dimensions (W x H x D)**
Screw terminal type : 72 x 144 x 272mm
Compression terminal type : 72 x 144 x 280mm
- **Mass** : 1.9 kg or less
- **Mounting method**
: Flush on indoor panel
Vertical mounting as standard
Tilted mounting allowed within backward angle 0° to 45°.

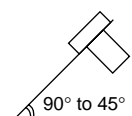

For panel cutout dimension, refer to Panel Cutout Dimensions

- **External terminal**
: Screw terminal type (M3.5) or Compression terminal type (by the code symbols)

12. Backup Function (option)

- **Method** : With backup operation unit
- **Number of control outputs**
 - : 1 output
- **Output signal** : DC4 to 20mA
- **Indicator** : 21-segment LED
- **Operation key** : Control output up, control output down,
- **Operation resolution**
 - : 5%
- **Backup changeover**
 - : Changeover has been made by the HM (Hard Manual) switch. However, changeover cannot be made when the backup operation unit is faulty.
 - : Balanceless and bumpless switching to the HM mode

13. Communications (option)

13-1 Modbus(R) protocol interface (option)

- **Communication mode**: Host communications
- **Communication protocol**: Modbus(R) protocol
- **Physical specifications**: EIA RS485
- **Communication mode**: Two-wire, half-duplex, start-stop synchronous mode
- **Connection mode**: Multi-drop connection
- **Communication speed**: Selectable from 2.4, 4.8, 9.6, 19.2, and 38.4 kbps.
Default setting: 19.2 kbps
- **Communication distance**: Total extension; 500 m
- **Data length**: Fixed to 8 bits
- **Parity**: Selectable from ODD, EVEN, or None.
- **Stop bit**: Selectable from 1 or 2.
- **Insulation**: Insulated from internal circuit
- **End of line resistor**: 100 Ω (option)
- **Communication item**: Parameter, measured value
- **RS232/RS485 converter (recommended item)**
Type: K3SC-10 (Insulated type by OMRON)

13-2 T-link interface (option)

- **Communication behavior**
 - : Master
- **Master communication**
 - : Connecting to CPU capsule
 - : I/O transmission ; 8-word outputs
- **Slave communication**
 - : None
- **Common item** : Wiring system ; multi-drop
 - : Communication speed ; 500kbps
 - : Communication distance; Max. 500m in total
 - : Isolation ; Not isolated from internal circuit
 - : Terminator ; 100 Ω (optional item)

14. Memory Card Interface (option)

- **Specification** : Compact Flash® (Based on CFA)
- **Compatible memory card**
 - : 5 V flash memory card
 - Capacity 4, 20 and 32 MB
- **Application** : Process data logging (3 points)
- **Saving period** : 1s min.
- **Data storage capacity**

Memory card capacity	Data storage
4MB	about 180 thousand data
20MB	about 900 thousand data
32MB	about 1.35 million data

[Remark] Values of 4 points are recorded simultaneously by one data.

[Note] The data of max. 16 points (4 screens) can be stored at storage time as 1 s.

- **Format method**
 - : Dependent on this controller
- **Data readout** : Readout by PC using PCMCIA card slot
- **Recommended memory card**
 - : Made by Sandisk corporation
 - Sandisk compact Flash memory card is standardized and on the market.
 - Models ; SDCFB-4-101-00 (4MB)
 - SDCFB-20-101-00 (20MB)
 - SDCFB-32-101-00 (32MB)

15. Standards under Conformity

(1) General safety

- : IEC 1010-1 (1990)
- EN 61010-1 (1993)

(2) EMC

- : Emission EN 50081-2 (1994)
- Immunity EN 50082-2 (1995)

Table 1

List of Thermocouple and Resistance Bulb Measurable range

Input signal	Input type code	Input range code	Measurable range °C		
Thermocouple	01	00	0.0~400.0		
		01	0.0~800.0		
		02	0.0~400.0		
		03	0.0~800.0		
		04	0.0~1200.0		
		05	0.0~1600.0		
		06	0.0~1800.0		
		07	-200.0~200.0		
		08	-150.0~400.0		
		09	0.0~800.0		
		10	-200.0~800.0		
		11	0.0~1600.0		
		12	0.0~1300.0		
		13	-200.0~400.0		
		14	0.0~2300.0		
Resistance bulb	00	00	0.0~150.0		
		01	0.0~300.0		
		02	0.0~500.0		
		03	0.0~600.0		
		04	-50.0~100.0		
		05	-100.0~200.0		
		06	-200.0~600.0		
		07	-200.0~850.0		
		Resistance bulb	JPt100	08	0.0~150.0
				09	0.0~300.0
				10	0.0~500.0
				11	0.0~600.0
				12	-50.0~100.0
				13	-100.0~200.0
				14	-200.0~600.0
PL II	15			0.0~1300.0	

SCOPE OF DELIVERY

Controller, panel mounting bracket, instruction manual (depend on code symbols)

Optional Items

Item	Type	Specification	Available unit
Terminator for communication (100 Ω)	PDZR1001	For screw terminal	1
	PDZR2001	For compression terminal	1
34-pin multiple connector (Note1)	PDZC1001	Solder type straight terminal	1
	PDZC2001	Solder type right angle terminal	1
	PDZC3001	Solderless type straight terminal	1
	PDZC4001	Solderless type right angle terminal	1
Shunt resistor (250 Ω)	PDZS1001	For screw terminal	1
	PDZS2001	For compression terminal	1
Communication cable (Note2)			
For screw terminal, from PDA to PDA	PDZK1xx1	M3.5 solderless terminals at both ends	1
For screw terminal, from PDA to PLC	PDZK2xx1	M3.5 solderless terminals at both ends	1
For screw terminal, from PDA to PC	PDZK3xx1	9-pin connector at PC side end	1
For compression terminal, from PDA to PDA	PDZK4xx1	With compression terminal at both ends	1
For compression terminal, from PDA to PLC	PDZK5xx1	With M3.5 solderless terminal on PLC side	1
For compression terminal, from PDA to PC	PDZK6xx1	9-pin connector on PC side	1
Replacing case	PDZE1002	For replasing CC-F	1
Compact Controller M (PDA1) Instruction Manual in book form (in Japanese)	PDZX1101	Instruction manual in book form	1
Compact Controller M (PDA1) Instruction Manual in book form (in English)	PDZX2101	Instruction manual in book form	1
Instruction Manual on CD-ROM (in Japanese and English) (Note3)	PDZQ1001	Instruction manual on CD-ROM	1
Mounting bracket (Note4)	PDZA1001	Improved mounting bracket	1

(Note 1) Screw terminal type. Required when using digital input/output.
 (Note 2) Cable for T-link/Modbus communication.
 (Note 3) The instruction manual in Japanese and English are included.
 (Note 4) This is the improved mounting bracket adopted from PDA-2.
 Refer to the outline diagram for shape and dimensions.

Block diagram of electrical isolation

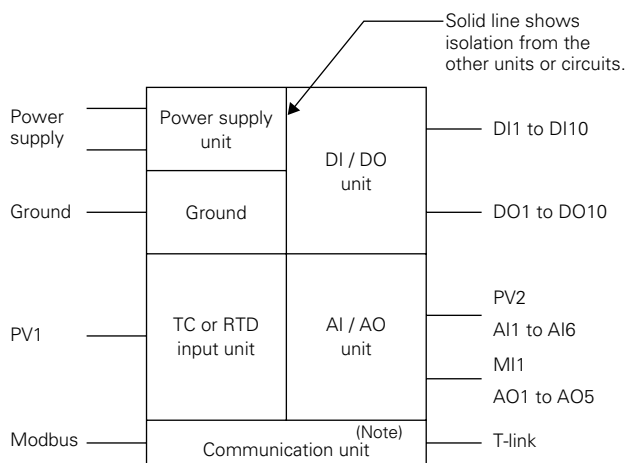

(Note) The communication unit is not isolated from the AI/AO unit when using T-link.

OUTLINE DIAGRAM (Unit : mm)

SCREW TERMINAL TYPE

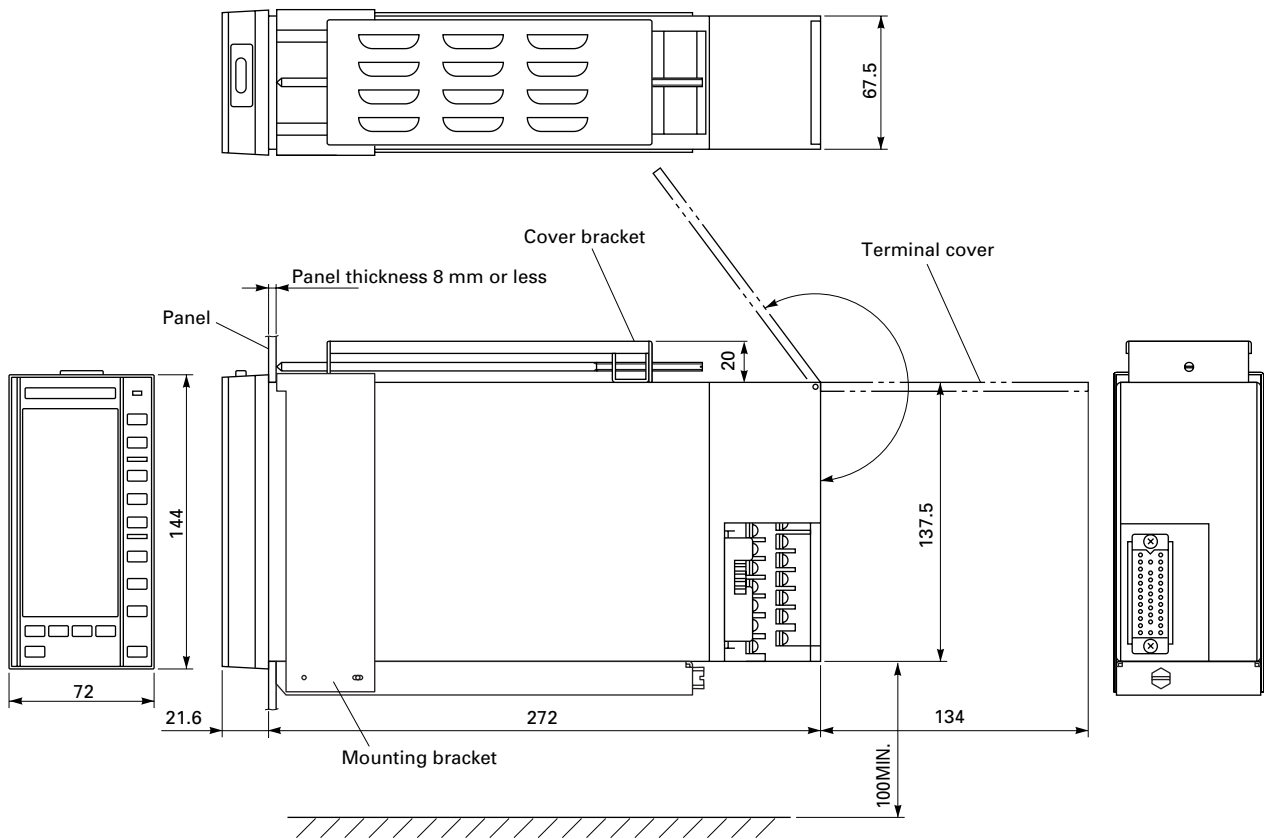

Note) The distance between other instruments and low end of PDA shall be more than 100mm.

COMPRESSION TERMINAL TYPE

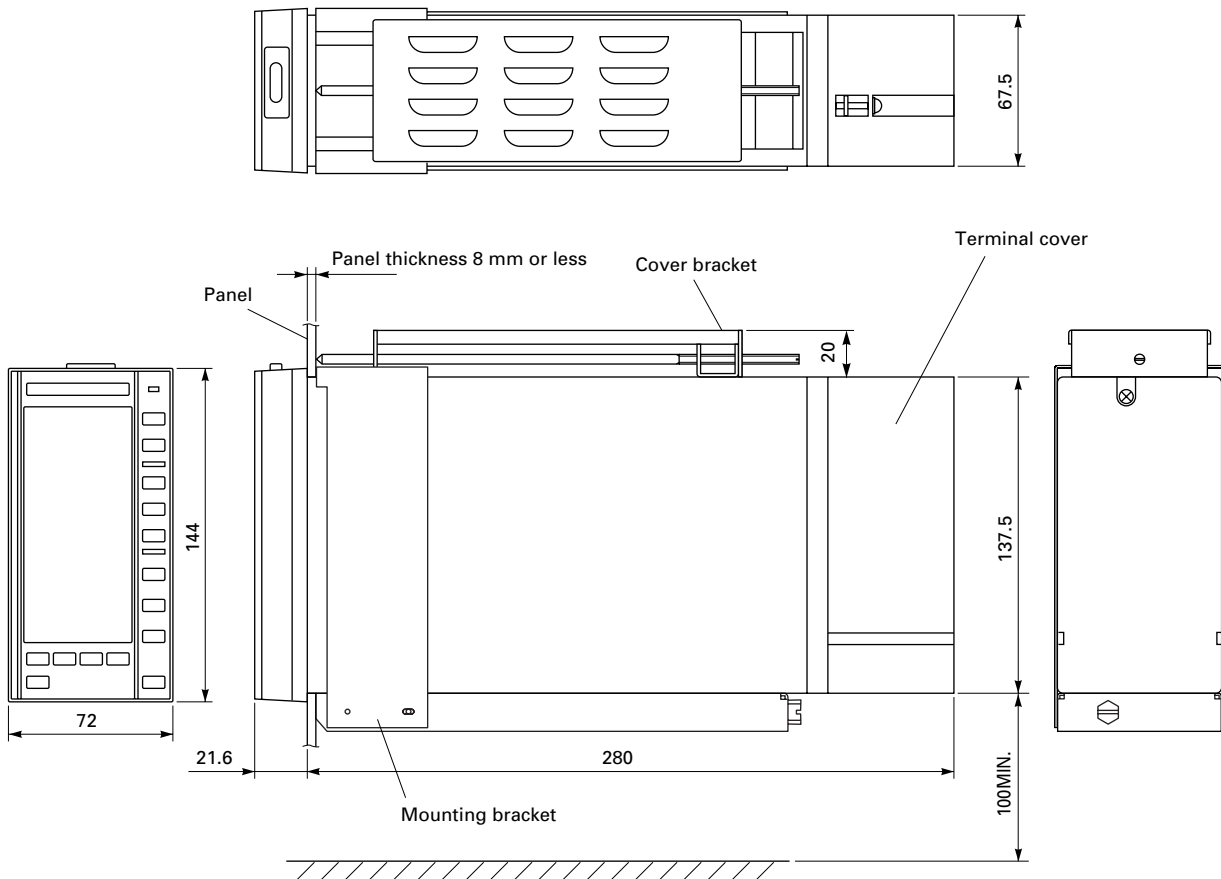

Note) The distance between other instruments and low end of PDA shall be more than 100mm.

MOUNTING BRACKET

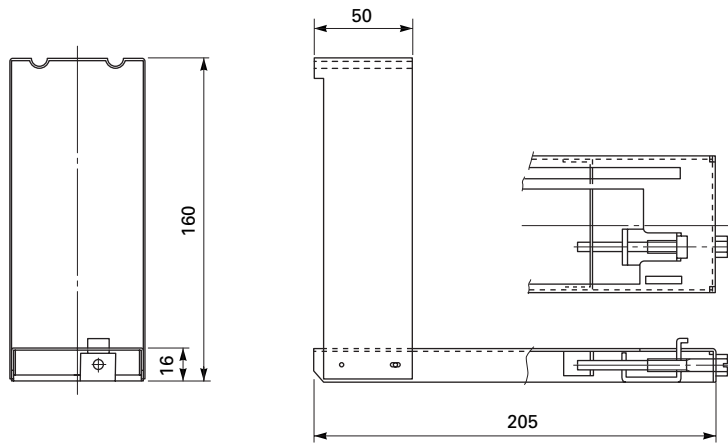

PANEL CUTOUT DIMENSIONS

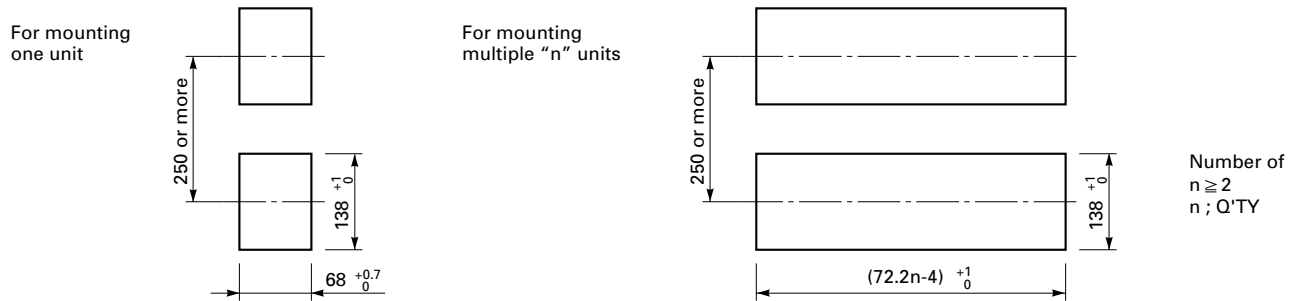

EXTERNAL CONNECTION DIAGRAM

SCREW TERMINAL TYPE M3.5 screw terminal section

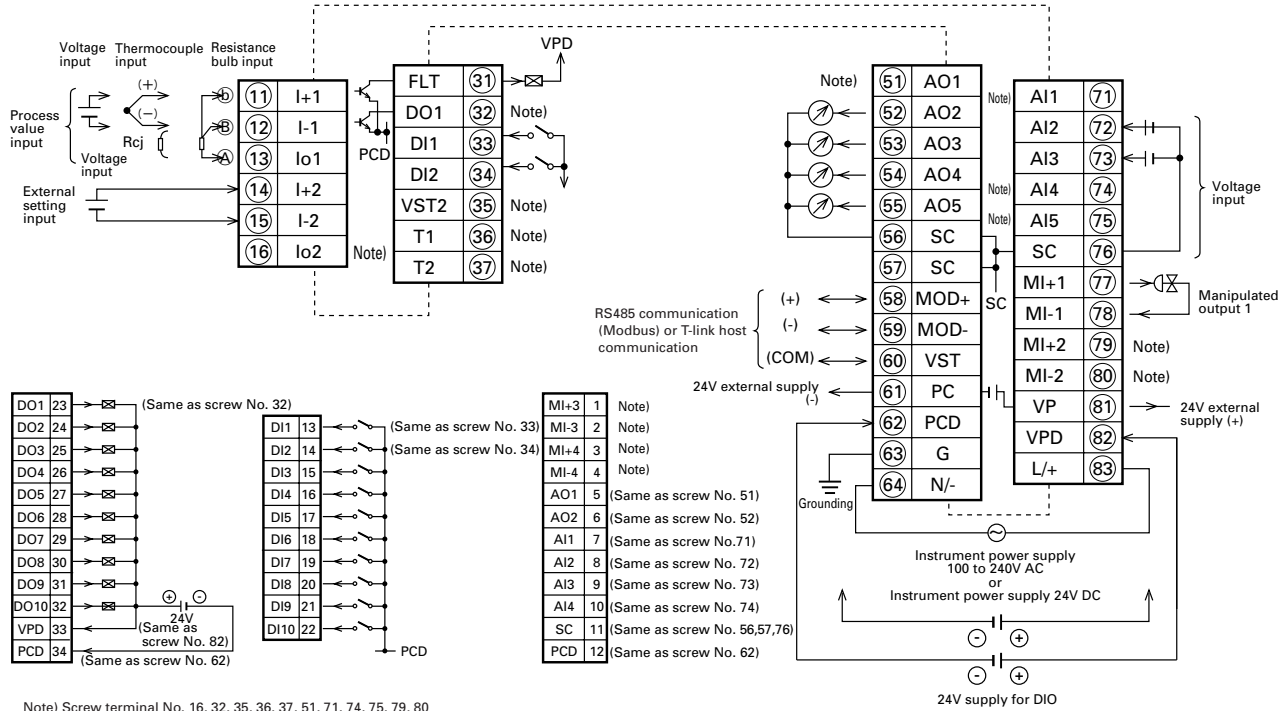

Note) Screw terminal No. 16, 32, 35, 36, 37, 51, 71, 74, 75, 79, 80
 Multiple connector terminal No. 1, 2, 3, 4 not usable (connection not allowed)

EXTERNAL CONNECTION DIAGRAM

COMPRESSION TERMINAL TYPE

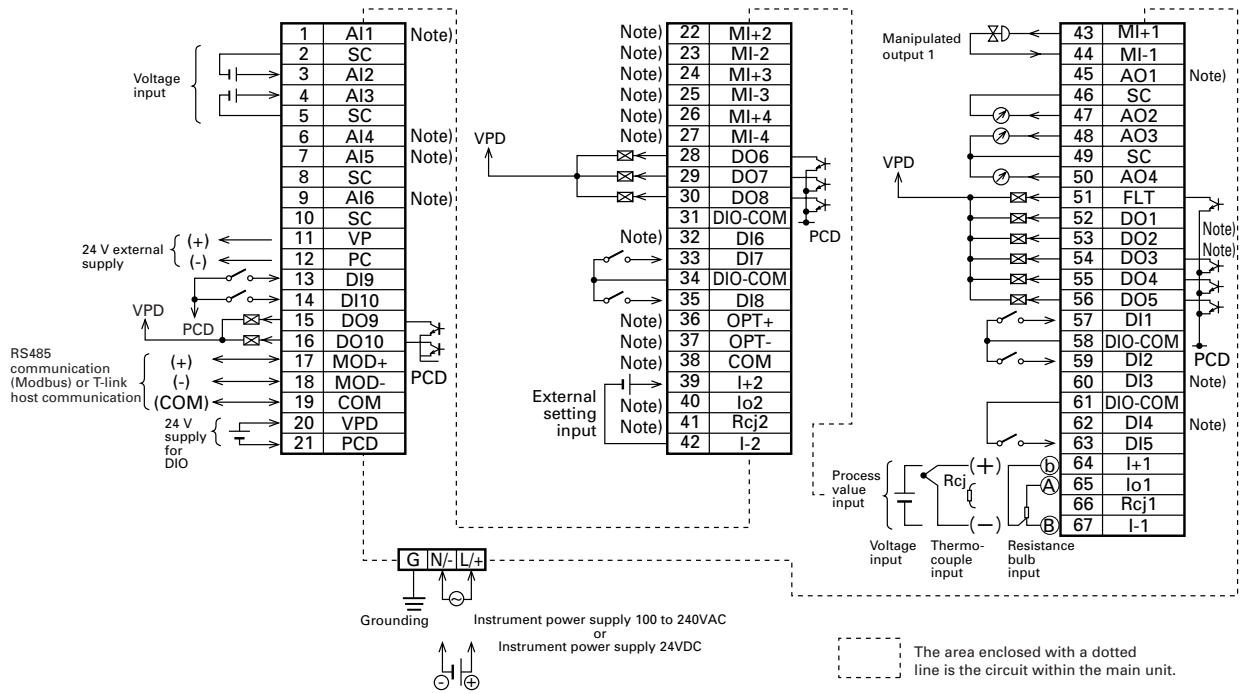

Note) Compression terminal No. 1, 6, 7, 9, 22, 23, 24, 25, 26, 27, 32, 36, 37, 38, 40, 41, 45, 52, 53, 60, 62 not usable (connection not allowed)

[Note] Windows® is the registered trade mark of Microsoft corporation.

[Note] Modbus® is a registered trademark of Schneider Electric Limited.

[Note] Compact Flash® is the registered trade mark of Sandisk corporation.

[Note] Pentium® is the registered trade mark of Intel corporation.

[Note] Adobe® and Acrobat® are trademarks of Adobe Systems Incorporated.

⚠ Caution on Safety

*Before using this product, be sure to read its instruction manual in advance.

Fuji Electric Systems Co., Ltd.

Head Office

Gate City Ohsaki, East Tower, 11-2, Osaki 1-chome,
Shinagawa-ku, Tokyo 141-0032, Japan

<http://www.fesys.co.jp/eng>

Instrumentation Div.

International Sales Dept.

No.1, Fuji-machi, Hino-city, Tokyo, 191-8502 Japan

Phone: 81-42-585-6201, 6202 Fax: 81-42-585-6187

<http://www.fic-net.jp/eng>

Information in this catalog is subject to change without notice.

Printed in Japan