

Digital Controller **COMPACT CONTROLLER M [CC-M]** (FIXED FUNCTION/ STEP OUTPUT TYPE)

DATA SHEET

PDC1

The Compact Controller M (fixed function/step output type) is a single-loop process controller.

Receiving 1 to 5V DC signals as well as those from thermocouples and resistance bulbs as input signals, it performs advanced controls such as PID control, square root extraction, and non-linear control.



FEATURES

1. Single-loop controller with control output

The controller has a single-loop control function.

2. High visibility ensured by color graphic display

A color LCD is adopted for clear graphic displays such as bar graph and trend displays.

3. Networking (option)

Communication can be carried out over our PLC-link (T-link) or Modbus (RS485) network.

4. Memory card (option)

The data such as process input data and control output data can be saved in memory cards.

FUNCTIONAL DIAGRAM

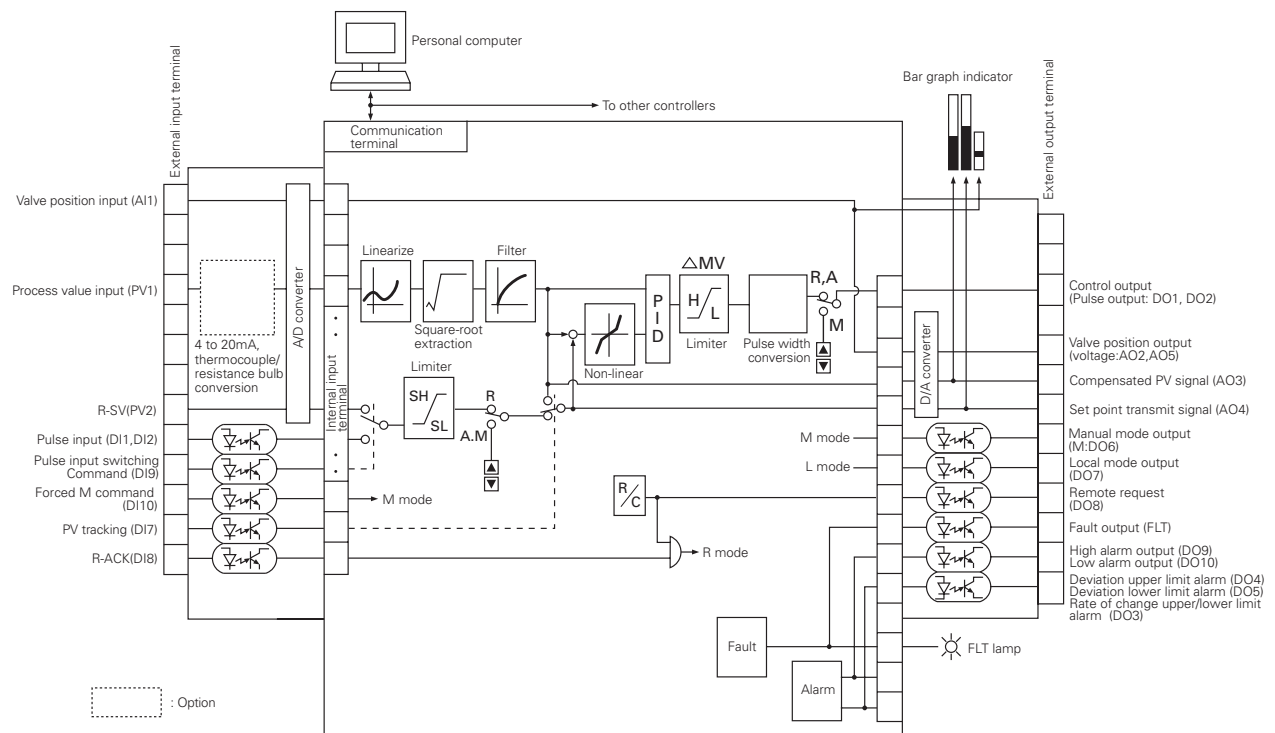

SPECIFICATIONS

1. Control Functions

(1) PID control

- **Number of loops and PID:**
1 loop (1 control output / 1PID)
- **Proportional band (P):**
1.0 to 3276.7%, set at 3000.0% for delivery
- **Integration time (I):**
0.1 to 3276.7 s, set at 3000.0 s for delivery
- **Derivative time (D):**
0.0 to 900.0 s, set at 0.0 s for delivery

(2) Computation cycle:

100 ms

(3) Alarm function

- **Kinds** : Each high/low of PV and SV, PV change rate alarm, high/low deviations.

2. Input Signals

Performance in standard operating conditions (23±2°C, 55±10% RH, power supply voltage 100 V AC to 240 V AC power frequency 50/60 Hz, or 24 V DC, without vibration and external noise).

2-1 Analog input signal

- **Number of inputs:**
3 (points used)
- **Input signal types:**
DC voltage, thermocouple (option), resistance bulb (option)
One thermocouple input or one resistance bulb input are selectable in Code Symbol.
- (1) **DC voltage/DC current**
 - Open-angle input is assigned to AI1 in an unchangeable manner.
 - **Input range:** Selectable among 0 to 5 V DC, 1 to 5 V DC and 0 to 10 V DC
Initial set before delivery : 1 to 5 V DC
 - **Input accuracy:** ±0.1% of input span±1 digit
 - **Scaling (Engineering data conversion):**
Settable within a range from -32767 to 32767
4, 3, 2, 1 or 0 digit below decimal point is selectable.
Initial set before delivery : 0.00% to 100.00%
 - **Engineering unit:** Settable in up to 8 characters
Usable characters: Alphabets numerals, symbols such as +, -, *, etc.
 - **Input accuracy guarantee range:** -5% to 105% of input range. However, minus inputs are excluded.
 - **Maximum continuous permissible voltage:** ±35 V
 - **Input resistance:** 1 MΩ or more
 - **Influence by ambient temperature:** ±0.1% FS/10°C or less.
 - **Influence by power supply fluctuation:** ±0.1% FS or less.
 - **Isolation:** Non-isolated from internal circuit.

- **In case of current input:**
Shunt resistor need to be connected to the analog input terminal.
(250 Ω shunt resistor is optional item)

(2) Thermocouple (option)

- **Types and measurable ranges:**
* See Table 1.
- **Input accuracy:** ±0.2% FS ±1 digit
[Note]B type: ±5% between 0 to 400°C
S and R type: ±1% between 0 to 500°C
All type of TC: ±5% under -100°C
- **Reference junction compensation error:**
±1.0°C (provided measurable range is -50°C and higher)
[Note]Reference junction compensation resistor is connected at external input terminal in case of thermocouple input is ordered.
- **Input accuracy guarantee range:**
-5% to 105% of input range
- **Input resistance:** 1MΩ or more
- **Influence by signal source resistance:**
About 0.25 μV/Ω
- **Influence by ambient temperature:**
±0.2% FS/10°C ±1°C or less.
- **Influence by power supply fluctuation:**
±0.2% FS ±1°C or less
- **Burnout detection:** Provided
- **Isolation:** Isolated from internal circuit.

(3) Resistance bulb (option)

- **Types and measurable ranges:**
* See Table 1.
- **Input accuracy:** ±0.2% FS ±1 digit
- **Input accuracy guarantee range:**
-5% to 105% of input range
- **Allowable wiring resistance:** 10Ω or less per wire, provided wiring resistance must be equal among 3 wires (Zener barrier connection unallowable)
- **Influence by ambient temperature:** ±0.2% FS/10°C or less.
- **Influence by power supply fluctuation:** ±0.2% FS or less
- **Burnout detection:** Provided
- **Isolation:** Isolated from internal circuit.

[Note] FS: full span.

- **Sampling period:**
100 ms

2-2 Digital input signal

- **Number of inputs:**
6 inputs
- **Electrical specifications:**
No-voltage contact or transistor contact
ON/0 V, OFF/24 V, ON current/about 8 mA
Isolated from the internal circuit by photocoupler. Not isolated between each digital input and output.
- **Contact rating:** 30 V DC, 10 mA or more

- **Signal judgment:**
 - No-voltage contact
 - Contact resistance;
 - 200 Ω or less at ON,
 - 100 kΩ or more at OFF
 - Transistor contact
 - 1V max at ON.,
 - leakage current 100μA max. at OFF

3. Output Signals

Performance in standard operating conditions (23±2°C, 55±10% RH, power supply voltage 100 V AC to 240 V AC power frequency 50/60 Hz, or 24 V DC, without vibration and external noise).

3-1 Analog output signal

(1) Auxiliary analog output

- **Number of outputs:**
 - 4 (points used)
- **Types of signal:** Selectable among 0 to 5 V DC, 1 to 5 V DC and 0 to 10 V DC
 - Initial set before delivery: 1 to 5 V DC
- **Output accuracy:**
 - ±0.1% FS
- **Load resistance:**
 - 15 kΩ or more
- **Output guarantee range:**
 - 1 to 5 VDC : -12.5% to 112.5%
 - 0 to 5 VDC : 0% to 112.5%
 - 0 to 10VDC : 0% to 105%
- **Influence by power supply fluctuation:**
 - ±0.1% FS or less
- **Isolation** : Non-isolated from internal circuit

3-2 Control output signal

- **Number of outputs:**
 - 1 pair
 - Increasing pulse; DO1
 - Decreasing pulse; DO2
- **Electrical specifications:**
 - Transistor open collector
 - 1 V max. at ON, 10 μA max at OFF.
 - Isolated from the internal circuit by photocoupler. Not isolated between each digital input and output.
- **Output rating** : 30 V DC, 100 mA max. (resistive load)
 - [Note] Control outputs should be crossed sequentially by an external sequence so that the increasing and decreasing pulse signals are not turned to ON at the same time.

3-3 Digital output signal

- **Number of outputs:**
 - 8 (points used)
- **Electrical specifications:**
 - Transistor open collector
 - 1 V max. at ON, 10 μA max at OFF.
 - Isolated from the internal circuit by photocoupler. Not isolated between each digital input and output.
- **Output rating** : 30 V DC, 100 mA max. (resistive load)

3-4 Fault output signal (terminal symbol FLT)

- **Number of outputs:**
 - 1 output
- **Electrical specifications:**
 - Transistor open collector
 - 1 V max. at ON, 10 μA max at OFF.
 - Isolated from the internal circuit by photocoupler. Not isolated between each digital input and output.
- **Output rating** : 30 V DC, 100 mA max. (resistive load)

4. Display

- **Display unit** : 16 Colors graphic liquid crystal display, with CFL back light and contrast adjust function.
- **Contents of display:**
 - Menu
 - Loop panel
 - Bar graph display, digital display, etc.
 - Tuning screen
 - Trend screen
 - Alarm and alarm historical screen
 - Analog input/output and digital input/output indication screen
 - Parameter setting screen

5. Setting and Operation

(1) Set point setting method

- **Setting key** : Up key/down key
- **Setting speed** : About 40 s/FS
- **Setting resolution:**
 - 0.05% FS/each key press

(2) Control output operation method

- **Operation key** : Up key, down key

(3) Operation mode

- **Selectable operation modes:**
 - C (or R), A and M modes
- [Note] C: Cascade mode (mode of operation according to external set value)
- R: Remote mode (mode of operation according to external set value)
- A: Auto mode (mode of operation according to the value set on front face of this controller)
- M: Manual mode (operation mode in which operator manipulates control output manually)
- [Supplement] In the C and R modes, operations are the same, i.e., only the markings on the nameplate are different.

• **Setting method :**

Selection is required in Code Symbol among the following.

C-A-M

A-M

R-A-M

• **Operation mode changeover:**

Balance bumpless transfer from A to R and from A to C. Balanceless bumpless transfer in other mode changeover.

[Note] Balance bumpless transfer is a mode in which the operator is required to balance each SV for transfer.

Balanceless bumpless transfer is a mode in which the controller automatically balances each SV for transfer.

(4) Security

- **Method** : Setting of a password
- **Password** : Settable in 4 numerals (within 0000 to ffff)
Initial set before delivery: 0000
- **Contents of security:**
Inhibition of parameter setting

(5) Other setting items

- **Tag name** : Settable in up to 8 characters
Usable characters; alphabets, numerals, symbols such as +, -, *, etc.

6. Power Supply

- **Voltage rating** : 100 V to 240 V AC/24 V DC
[as specified in Code Symbol]
- **Allowable range:**
85 V to 264 V AC/20 V to 30 V DC
[as specified in Code Symbol]
- **Frequency** : 47 to 63 Hz
- **Power consumption:**
60 VA or less (100 V to 240 V AC)/
30 W or less (24 V DC)
[as specified in Code Symbol]
- **Power supply output voltage:**
(terminal symbol VP and PC)
20V to 30V DC, max. 40mA

7. General performance and characteristics

- **Insulation resistance:**
500 V DC, 50 MΩ or more.
- **Dielectric strength:**
 - 2,000 V AC for 1 minute between power terminal and ground terminal in case of 100 V to 240 V AC power supply
 - 500 V AC for 1 minute between power terminal and ground terminal in case of 24 V DC power supply.
 - 500 V AC for 1 minute between signal communication terminals and ground terminal
- **Rush current** : 60 A or less. (100 V AC to 240 V AC power supply)
- **Clock** : Set and display year, month, day, hour, minute, second
Accuracy : ±100 ppm (monthly gain/loss about 4 minutes) except of time lag shorter than 1 s / power ON / OFF action.
- **Memory backup:**
 - Protection by lithium battery.
(expected battery life is about 2 years under room temperature)
 - Parameter and program are stored in non-volatile memory.

8. Operating and storage conditions

- **Installation site** : Indoors
- **Operating temperature:**
0 to 50°C
0 to 40°C in case of multiple mounting
Temperature change rate: Max. 10°C / h
- **Transport and storage temperature:**
-20 to 70°C
(Temperature change rate: Max. 20°C / h)
- **Operating humidity:**
5 to 90% RH, condensation unallowable
- **Transport and storage humidity:**
5 to 95% RH, condensation unallowable
- **Operating continuous vibration:**
4.9 m/s² or less
- **Transport and storage shock:**
Fall of 60cm max. in packed status

9. Power Failure and restart Function

- **Permissible duration of momentary power failure:**
20 ms at 90V AC (100 V to 240 V AC only)
[Note] In case of 24 V DC, system power supply unit (model: PXJ) is recommended to avoid power failure problem.
- **Behavior at power failure detection:**
Control stops at detection of power failure.
- **Power recovery mode:**
Selectable initial start and continuous start

10. Self-Diagnosis

- **Control and computation circuit failure:**
Monitoring with watchdog timer
- **Input signal failure:**
 - Voltage/current input
Monitoring of range over
 - Thermocouple and resistance bulb
Monitoring of disconnection
- **Behavior at failure:**
: FLT is indicated, FLT lamp lights, FLT output signal turns on, control stops and control output is OFF (Open-angle of valve is held).

11. Structure

- **Enclosure** : Plastic (material: PC-ABS)
- **Finish color** : Front frame and enclosure both gray
- **Flame resistance:**
UL94V-0
- **Protection** : Front face; IP54 (display unit and operation key)
- **External dimensions (width x height x depth):**
Screw terminal type 72 x 144 x 272 mm
Compression terminal type 72 x 144 x 280 mm
- **Mass** : 1.9 kg or less

• **Mounting method:**

Flush on indoor panel
 Vertical mounting as standard
 Tilted mounting allowed within backward angle 0° to 45°.

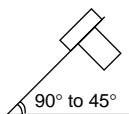

For panel cutout dimension, refer to Panel Cutout Dimensions

• **External terminal:**

Selectable in Code Symbol between the following.
 Screw terminal type (M3.5)
 Compression terminal type

12. Communications (option)

12-1 Modbus(R) protocol interface (option)

- **Communication mode:** Host communications
- **Communication protocol:** Modbus(R) protocol
- **Physical specifications:** EIA RS485
- **Communication mode:** Two-wire, half-duplex, start-stop synchronous mode
- **Connection mode:** Multi-drop connection
- **Communication speed:** Selectable from 2.4, 4.8, 9.6, 19.2, and 38.4 kbps.
Default setting: 19.2 kbps
- **Communication distance:** Total extension; Max. 500 m
- **Data length:** Fixed to 8 bits
- **Parity:** Selectable from ODD, EVEN, or None.
- **Stop bit:** Selectable from 1 or 2.
- **Insulation:** Isolated from internal circuit
- **End of line resistor:** 100 Ω (option)
- **Communication item:** Parameter, measured value
- **RS232/RS485 converter (recommended item)**
Type: K3SC-10 (Insulated type by OMRON)

12-2 T-link interface (option)

- **Communication mode:**
 Communication with upper level
- **High order communication:**
 Connection with CPU capsule
 I/O transmission; 8 words output
- **Low order communication:**
 None
- **Common item:** Topology; Multidrop
 Communication speed; 500 kbps
 Communication distance;
 Max. 500 m in total extension distance
 Isolation; Not isolated from internal circuit
 Terminating resistor; 100 Ω (separately available)

13. Memory Card Interface (option)

- **Specification :** Compact Flash® (Based on CFA)
- **Compatible memory card:**
 5 V flash memory card
 Capacity 4, 20 and 32 MB
- **Application :** Process data logging (3 points)
- **Saving period :** 1s to 2h

• **Data storage capacity:**

| Memory card capacity | Data storage |
|----------------------|-------------------------|
| 4MB | about 180 thousand data |
| 20MB | about 900 thousand data |
| 32MB | about 1.35 million data |

[Note] The data of max. 16 points (4 screens) can be stored at storage time as 1 s.

• **Format method:**

Dependent on this controller

• **Data readout :** Readout by PC using PCMCIA card slot

• **Recommended memory card:**

Made by Sandisk corporation
 Sandisk compact Flash memory card is standardized and on the market.

14. Standards under Conformity

(1) **General safety:**

IEC 1010-1 (1990)
 EN 61010-1 (1993)

(2) **EMC**

: Emission EN 50081-2 (1994)
 Immunity EN 50082-2 (1995)

[Caution on use]

1. Unlike the preceding models, a potentiometer interface (resistance input) for inputting the open angle of a motor-operated valve is not incorporated. For the above purpose, therefore, voltage input is required with a signal converter externally connected.
 Also, since open-angle input is assigned between AI1 and SC, this input will be indicated on the MV indicator.
2. Control output is assigned to the multi-connector section. So, a 34-pin multi-connector should be prepared depending on your specifications, referring to "Items to be ordered separately (Items separately available)."
3. For control output, crossing interlock with relays or the like interlock is required so that both incremental and decelerational pulse signals will not turn on simultaneously.

Table 1

List of Thermocouple and Resistance Bulb Measurable range

| Input signal | Input type code | Input range code | Measurable range °C | |
|-----------------|-----------------|------------------|---------------------|--------------|
| Thermocouple | 01 | 00 | 0.0~400.0 | |
| | | J | 01 | 0.0~800.0 |
| | | K | 02 | 0.0~400.0 |
| | | K | 03 | 0.0~800.0 |
| | | K | 04 | 0.0~1200.0 |
| | | R | 05 | 0.0~1600.0 |
| | | B | 06 | 0.0~1800.0 |
| | | T | 07 | -200.0~200.0 |
| | | T | 08 | -150.0~400.0 |
| | | E | 09 | 0.0~800.0 |
| | | E | 10 | -200.0~800.0 |
| | | S | 11 | 0.0~1600.0 |
| | | N | 12 | 0.0~1300.0 |
| | | U | 13 | -200.0~400.0 |
| | | WRe5-26 | 14 | 0.0~2300.0 |
| PL II | 15 | 0.0~1300.0 | | |
| Resistance bulb | Pt100 | 00 | 00 | 0.0~150.0 |
| | | | 01 | 0.0~300.0 |
| | | | 02 | 0.0~500.0 |
| | | | 03 | 0.0~600.0 |
| | | | 04 | -50.0~100.0 |
| | | | 05 | -100.0~200.0 |
| | | | 06 | -200.0~600.0 |
| | 07 | | -200.0~850.0 | |
| | JPt100 | | 08 | 0.0~150.0 |
| | | | 09 | 0.0~300.0 |
| | | | 10 | 0.0~500.0 |
| | | | 11 | 0.0~600.0 |
| | | | 12 | -50.0~100.0 |
| | | | 13 | -100.0~200.0 |
| 14 | | -200.0~600.0 | | |

SCOPE OF DELIVERY

Controller, panel mounting bracket, instruction manual (depend on code symbols)

Items to be ordered separately (items separately available)

| Item | Type | Specificatio | Unit of sale |
|--|----------|--|--------------|
| Terminating resistor (100 Ω) | PDZR1001 | For screw terminal | 1 |
| | PDZR2001 | For compression terminal | 1 |
| 34-pin multi-connector (Note 1) | PDZC1001 | Soldering type straight terminal | 1 |
| | PDZC2001 | Soldering type right-angle terminal | 1 |
| | PDZC3001 | Solderless type straight terminal | 1 |
| | PDZC4001 | Solderless type right-angle terminal | 1 |
| Shunt resistor (250 Ω) | PDZS1001 | For screw terminal | 1 |
| | PDZS2001 | For compression terminal | 1 |
| Communication cable (Note2) | | | |
| For screw terminals between PDC and PDC | PDZK1xx1 | With M3.5 solderless terminal at both ends | 1 |
| For screw terminals between PDC and PLC | PDZK2xx1 | With M3.5 solderless terminal at both ends | 1 |
| For screw terminals between PDC and PC | PDZK3xx1 | 9-pin connector on PC side | 1 |
| For compression terminal between PDC and PDC | PDZK4xx1 | With compression terminal at both ends | 1 |
| For compression terminal between PDC and PLC | PDZK5xx1 | With M3.5 solderless terminal on PLC side | 1 |
| For compression terminal between PDC and PC | PDZK6xx1 | 9-pin connector on PC side | 1 |
| Extension case (under development) | PDZE2002 | For CC-F replacement | 1 |
| Printed instruction manual (written in Japanese) for compact controller M (PDC1) | PDZX6101 | Printed instruction manual | 1 |
| Printed instruction manual (written in English) for compact controller M (PDC1) | PDZX7101 | Printed instruction manual | 1 |
| Instruction manual in CD-ROM (common for Japanese and English) (Note 3) | PDZQ1001 | CD-ROM version instruction manual | 1 |
| Fixture (Note 4) | PDZA1001 | Improved fixture | 1 |

(Note 1) Screw terminal type required for using control output and digital input/output (see Outline Diagram). Prepare separately if needed.

(Note 2) Transmission cable for T-link/Modbus communication.

(Note 3) This CD-ROM contains the instruction manuals written in Japanese and English.

(Note 4) An improved fixture adopted starting from the PDC-2. For the shape and dimensions, refer to Outline Diagram.

Block diagram of electrical isolation

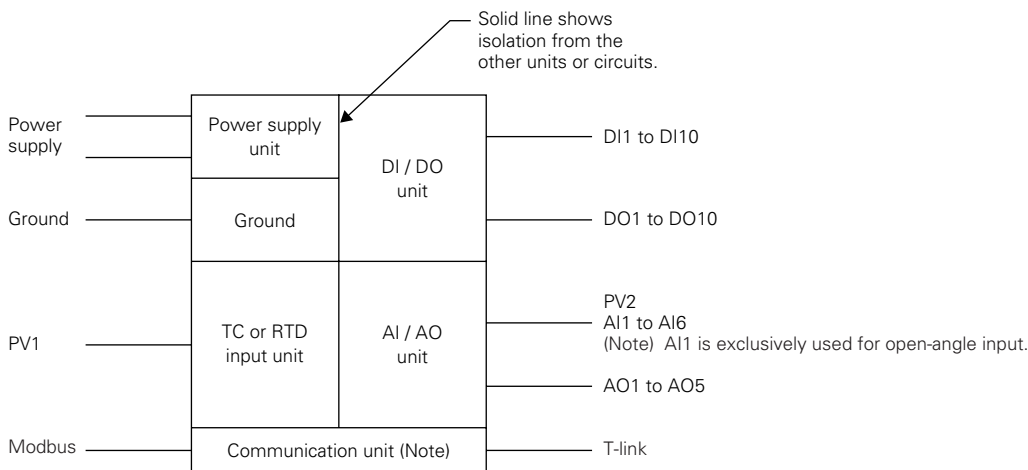

(Note) Not isolated from the analog input/output section in case of T-link.

CODE SYMBOLS

| 1 | 2 | 3 | 4 | 5 | 6 | 7 | 8 | 9 | 10 | 11 | 12 | 13 | 14 | 15 | Description | | |
|---|---|---|---|---|---|---|---|---|----|----|----|----|----|----|-------------|---|-------------------------|
| P | D | C | | | | | 2 | - | | | | | | 1 | 0 | Equipment function <4th digit> With fixed function | |
| | | | 1 | | | | | | | | | | | | | Number of control loops <5th digit> 1 loop (1 control output) | |
| | | | | 1 | | | | | | | | | | | | External terminal <6th digit> M3.5 screw Compression terminal | |
| | | | | | 2 | | | | | | | | | | | Input signal <7th digit> 1 to 5 V DC (DC4 to 20mA) Note 1 Thermocouple : 1 Resistance bulb Pt100 : 1 Resistance bulb JPt100 : 1 | |
| | | | | | | A | | | | | | | | | | Power supply voltage <9th digit> 100 V to 240 V AC (usable range 85 V to 264 V AC), 50/60 Hz 24 V DC (usable range 20 V to 30 V DC) | |
| | | | | | | C | | | | | | | | | | | |
| | | | | | | D | | | | | | | | | | | |
| | | | | | | E | | | | | | | | | | | |
| | | | | | | | | | | | | | | | | | |
| | | | | | | | | A | | | | | | | | Setting method <10th digit> C-A-M type A-M type R-A-M type | |
| | | | | | | | | B | | | | | | | | | |
| | | | | | | | | | C | | | | | | | | |
| | | | | | | | | | A | | | | | | | | |
| | | | | | | | | | R | | | | | | | Backup operation unit <11th digit> None | |
| | | | | | | | | | | | | | | | | | |
| | | | | | | | | | | | | | | | | | |
| | | | | | | | | | | | | | | | | | |
| | | | | | | | | | | | | | | | | | |
| | | | | | | | | | | | | | | | | | |
| | | | | | | | | | | | | | | | | Communication function/memory card interface <12th digit> Notes 2 and 3 (Slave communication) (Master communication) (Memory card interface) | |
| | | | | | | | | | | | | | | | | | Without Without Without |
| | | | | | | | | | | | | | | | | | Without Without With |
| | | | | | | | | | | | | | | | | | Modbus Without Without |
| | | | | | | | | | | | | | | | | | Modbus Without With |
| | | | | | | | | | | | | | | | | | T-link Without Without |
| | | | | | | | | | | | | | | | | | T-link Without With |
| | | | | | | | | | | | | | | | | Instruction manual <13th digit> None CD-ROM version instruction manual (common for both Japanese and English) Note 4 | |
| | | | | | | | | | | | | | | | | | |

Note 1) For current input, conversion into a voltage is required using a shunt resistor.
This resistor is separately available.

Note 2) The communication cable and terminating resistor are separately available.

Note 3) Memory card should be purchased from a dealer such as personal computer shop.

Note 4) The relevant manual is stored in the PDF file format.

For reading the manual, Adobe® Acrobat® Reader is required.

The CD-ROM also contains the Acrobat® Reader setup program.

Input signal and measurable range will meet the following specifications for product delivery.

For specification of voltage input : 0.00 to 100.00% scale

For specification of thermocouple : K thermocouple, measurable range 0.0 to 400.0°C

For specification of resistance bulb : Measurable range 0.0 to 150.0°C with both Pt and JPt

OUTLINE DIAGRAM (screw terminal type) (Unit : mm)

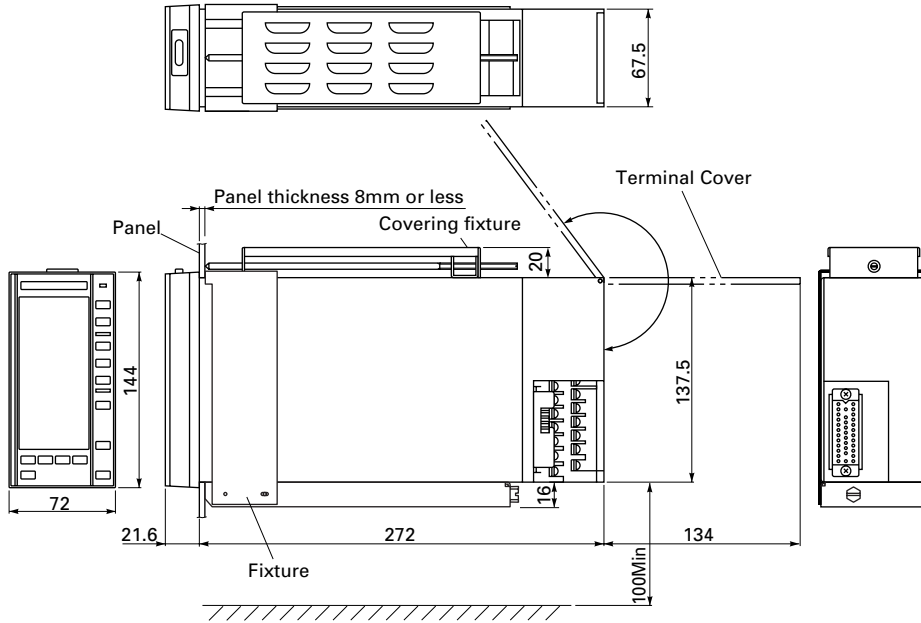

Note) When there is any object like other instrument or floor below the controller, an open space of 100 mm min. is required between the bottom face of controller and such an object.

OUTLINE DIAGRAM (compression type) (Unit : mm)

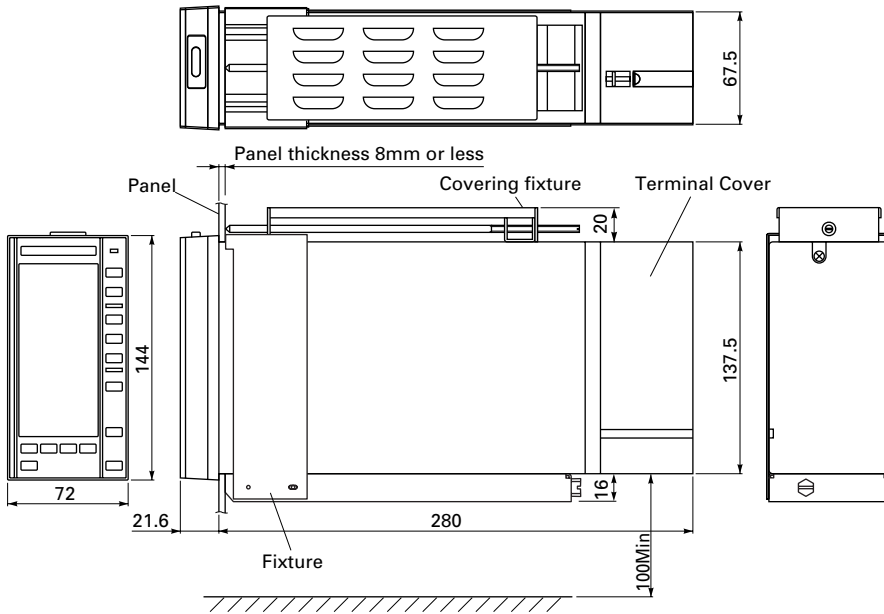

Note) When there is any object like other instrument or floor below the controller, an open space of 100 mm min. is required between the bottom face of controller and such an object.

PANEL CUTOUT DIMENSIONS

For mounting one unit

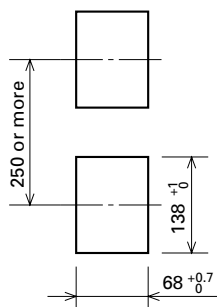

For mounting multiple "n" units

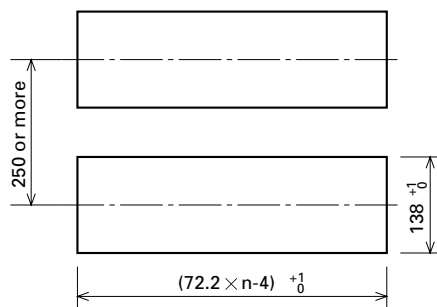

Number of units
 $n \geq 2$

FIXTURE

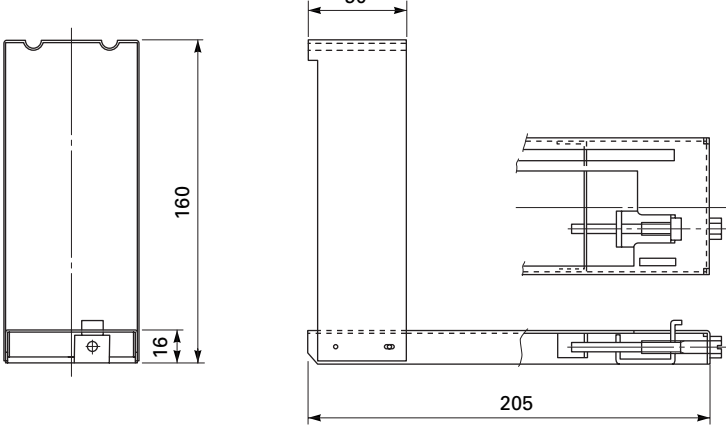

EXTERNAL CONNECTION DIAGRAM (Screw terminal type, M3.5 screw section)

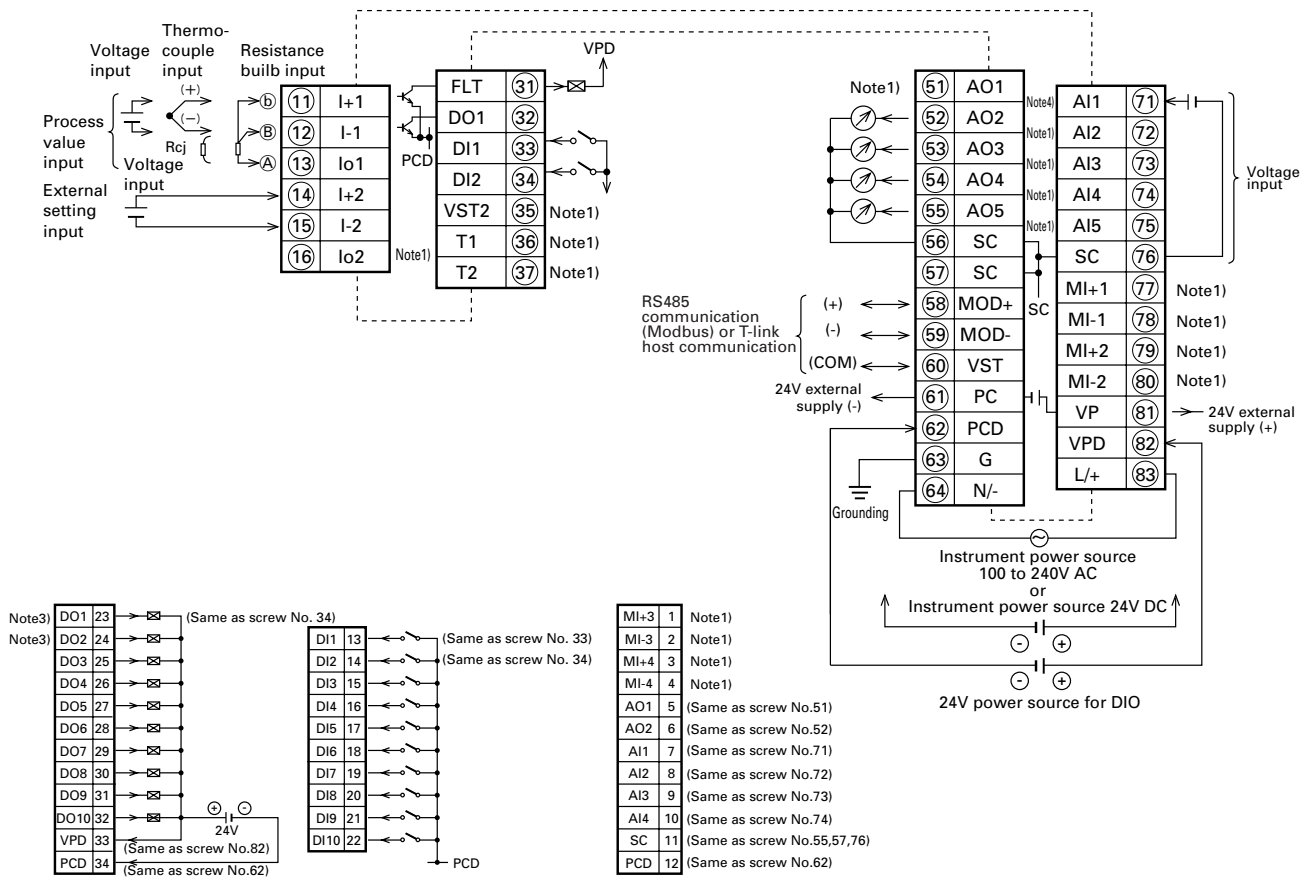

- Note 1) Screw terminals No. 16, 35, 36, 37, 51, 72, 73, 74, 75, 77, 78, 79, 80 and MULTI-CONNECTOR No. 1, 2, 3, 4 do not used (can't connect).
- Note 2) Control output is allocated to MULTI-CONNECTOR No. 23 and 24. Prepare a mult-connector (any one below) separately.

| | |
|----------|--------------------------------------|
| PDZC1001 | Soldering type straight terminal |
| PDZC2001 | Soldering type right-angle terminal |
| PDZC3001 | Solderless type straight terminal |
| PDZC4001 | Solderless type right-angle terminal |

- Note 3) Control output should be cross-connected to each other, externally.

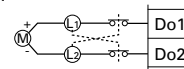

- Note 4) Connect open-angle input between screw terminals Nos. 71 and 11. SC or multi-connector pin 7 and 11.

EXTERNAL CONNECTION DIAGRAM (Compression terminal type)

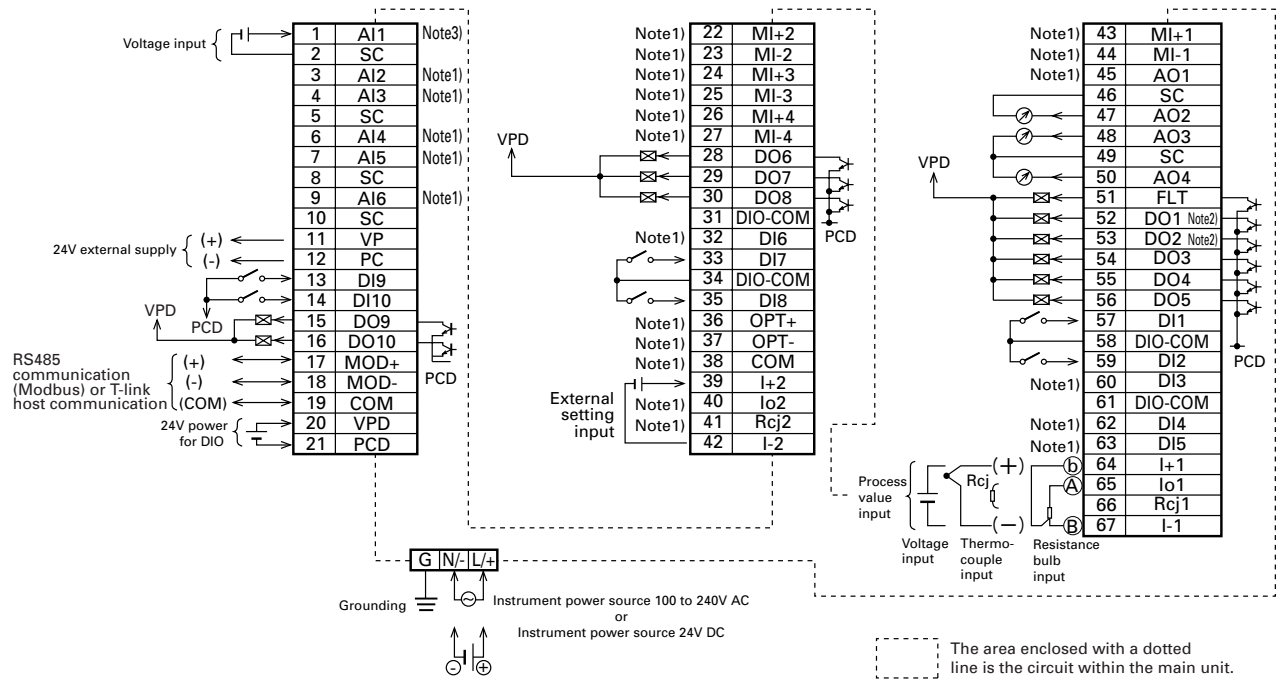

Note 1) Compression terminal No. 3, 4, 6, 7, 9, 22, 23, 24, 25, 26, 27, 32, 36, 37, 38, 40, 41, 43, 44, 45, 60, 62, 63 don't use (can't connect).

Note 2) Control output should be cross-connected to each other, externally.

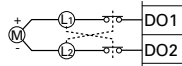

Note 3) Connect open-angle input between compression terminals Nos. 1 and SC.

[Note] Windows® is the registered trade mark of Microsoft corporation.

[Note] Modbus® is a registered trademark of Schneider Electric Limited.

[Note] Compact Flash® is the registered trade mark of Sandisk corporation.

[Note] Pentium® is the registered trade mark of Intel corporation.

[Note] Adobe® and Acrobat® are trade marks of Adobe Systems Incorporated.

⚠ Caution on Safety

*Before using this product, be sure to read its instruction manual in advance.

Fuji Electric Systems Co., Ltd.

Head Office

Gate City Ohsaki, East Tower, 11-2, Osaki 1-chome,
Shinagawa-ku, Tokyo 141-0032, Japan

<http://www.fesys.co.jp/eng>

Instrumentation Div.

International Sales Dept.

No.1, Fuji-machi, Hino-city, Tokyo, 191-8502 Japan

Phone: 81-42-585-6201, 6202 Fax: 81-42-585-6187

<http://www.fic-net.jp/eng>

Information in this catalog is subject to change without notice.

Printed in Japan