

NDIR TYPE INFRARED GAS ANALYZER

DATA SHEET

ZRH

This NDIR gas analyzer is used for measuring CO₂, CO, SO₂ and CH₄ and features a high accuracy, multiple functions and easy operation through use of a microprocessor. It is housed in an easy-to-use horizontal case (can be flush mounted on panel, mounted on 19 inch rack, placed on table top), or vertical case (can be flush mounted on panel, mounted on wall).

The analyzer provides a performance superior to the conventional double-beam system, is easy to maintain, and offers an excellent long-term stability. It is thus optimum for continuous measurement in the combustion control of various industrial furnaces, in research on garden-plants, and so on.



FEATURES

1. The use of a microprocessor provides high accuracy, multiple functions and easy operation.
 - Zero and span calibration is accurate and easy just by pressing the calibrating keys.
 - A self-diagnosis function is included.
 - An automatic calibrating function can be provided as an option.
 - Range can be changed over by a external signal as an option.
2. An improved optical system provides long term stability, and there is a minimum of drift caused by contamination of the measuring cell, so the long-term stability is excellent.
3. Adopting a serial dual-layer type of transmission detector minimizes remarkable the interface from other gas components.
4. Easy maintenance.

The single-beam photometric system uses a sample cell only and eliminates the necessity of delicate adjustment for optical balance. The instrument is designed as a unit of simple construction featuring easy maintenance and checks.

SPECIFICATIONS

Measurable gas components:

Single-component

CO₂, CO, SO₂, CH₄

Dual-component

CO₂/CO:
Landfill garbage application
CO₂: 0 to 50%
CH₄: 0 to 80%

Measuring range: Refer to measurable range combination table (page 5).

Measuring system:

Non-dispersion infrared-ray absorption method, deviation method, single light source – single beam

Output signal:

Output 1; 0 to 1V DC
Output 2; 4 to 20mA DC (optional allowable load resistance 550Ω or less).

Repeatability:

1st range (low range)
Within ±0.5% of full scale
2nd range (high range)
Within ± 1% of full scale

Linearity:

±2% of full scale

Zero drift:

Within ±2% of full scale/week

Span drift:

Within ±2% of full scale/week

Response time:

Within 15 seconds max. (for 90% response) depending on cell length

Power supply:

100V, 115V, 220V or 240V ±10% AC, 50/60Hz

Power consumption:

37VA max.

Ambient temperature:

-5 to +45°C

Ambient humidity:

90% RH or less

Enclosure: Steel casing, for indoor use

Storage condition:

Temperature; -20 to +60°C
Humidity; 100% RH max. (free from condensation)

Outer dimensions (H x W x D):

(1) Horizontal case
Rack mounting type; 133 x 483 x 435 mm
Panel flush mounting type;
133 x 443 x 435 mm
Table-top type; 145 x 443 x 435 mm

(2) Vertical case
Panel flush mounting type;
440 x 294 x 178 mm
Wall mounting type; 484 x 294 x 178 mm

Mass weight: Approx. 12Kg

Finish color: Munsell 2.5Y8.4/1.2

Display: 4 digit LED for concentration display
4 digit LED for sub-display

Output hold: Output value before manual or automatic calibration is hold. Whether or not to effect hold function can be selected.

Sample gas condition:

Temperature; 0 to 50°C
Dust; less than 0.3 µm
Pressure; less than 10 kPa

Standard adjustment gas:

Dry N₂ Balance

Warm up time: Approx. 2 hours

Material of gas-contacting parts:

Sample cell, SUS304, neoprene rubber
Infrared-ray transmitting window; CaF₂ or sapphire
Internal tubing; Toaron tube

Gas inlet/outlet, purge gas inlet size:

Rc1/4 (PT1/4 internal thread) or NPT1/4 internal thread

Measured gas flow rate:

1 ±0.5 liter/minutes

Purge gas flow rate:

Approx. 1 liter/minute

Scope of delivery: Analyzer, power fuse, manual, mounting bracket in the case of panel mounting type

Mounting method:

(1) Horizontal case
Mounted on 19 inch rack, or on panel, or on table-top

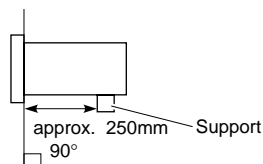

Remark: 70% or more of the analyzer weight should be supported at the bottom of the case. (In case of mounting panel or 19 inch rack, provide a support at the rear of casing.)

(2) Vertical case
Flush mounted on panel or mounted on wall

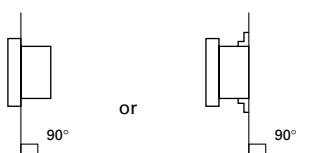

Installation conditions:

Install the analyzer at a place not exposed to direct sunlight or the radiation from a high temperature object. A void vibration, and select a clean place free of corrosive and/or combustible gases. If installing outdoors, provide a suitable casing or cover to protect the analyzer from wind, rain, etc.

Optional specifications

Remote output hold:

Analog output (DC0-1V, 4-20mA) is held via external signal.

Input signal: 5V DC

Remote range changeover:

Range is changeable via external signal. Range changeover input signal: 5V DC

Range identification signal output:

Contact output; 1 a contact
Contact capacity; 250V AC, 2A (resistive load)

Automatic calibration:

Zero and span are automatically calibrated at the preset cycle. Calibration gas is supplied sequentially by driving an electromagnetic valve installed outside.

Calibration channel:

Up to 2 components can be calibrated simultaneously.

Zero calibration point:

Fixed at 0%

Span calibration point:

50 to 100% full scale

Calibration start:

Via built-in timer or remote start signal

Output hold at calibration:

Possible

Calibration gas flow mode:

- (1) Zero gas
- (2) Zero gas – span gas 1
- (3) Zero gas – span gas 2
- (4) Zero gas – span gas 1 – span gas 2

Calibration gas flow time:

Settable from 100 to 599 sec.

Calibration cycle:

1 to 199 hours (in 1-hour step)

Calibration failure alarm:

Provided when fault occurs during auto calibration.

Contact output:

During calibration; 1 a (N.O) contact, contact capacity 250V AC, 2A (resistive load)

Calibration failure; 1 a (N.O) contact, contact capacity 250V AC, 2A (resistive load)

Electromagnetic valve drive; 1 a (N.O) contact, contact capacity 250V AC, 2A (resistive load)

Remote start:

Remote start signal; voltage input 5V DC

Measurable range combination table

(1) Single-component (CO₂ • CO • CH₄)

1st range	2nd range										
	F 0 to 1000 ppm	G 0 to 2000 ppm	U 0 to 2500 ppm	H 0 to 5000 ppm	J 0 to 1%	K 0 to 2%	L 0 to 5%	M 0 to 10%	N 0 to 20%	P 0 to 50%	R 0 to 100%
E 0 to 500 ppm	⊗ ○	⊗ ○	⊗ ○	—	—	—	—	—	—	—	—
F 0 to 1000 ppm	—	⊗ ○ △ □	⊗ ○ △ □	⊗ ○ △ □	—	—	—	—	—	—	—
G 0 to 2000 ppm	—	—	⊗ ○ △ □	⊗ ○ △ □	⊗ ○ △	—	—	—	—	—	—
U 0 to 2500 ppm	—	—	—	⊗ ○ △ □	⊗ ○ △	—	—	—	—	—	—
H 0 to 5000 ppm	—	—	—	—	⊗ ○ △	⊗ ○ △	—	—	—	—	—
J 0 to 1%	—	—	—	—	—	⊗ ○ △	⊗ ○ △	—	—	—	—
K 0 to 2%	—	—	—	—	—	—	⊗ ○ △	⊗ ○ △	—	—	—
Q 0 to 3%	—	—	—	—	—	—	⊗ ○ △	⊗ ○ △	—	—	—
L 0 to 5%	—	—	—	—	—	—	—	⊗ ○ △	—	—	—
M 0 to 10%	—	—	—	—	—	—	—	—	⊗ ○ △	⊗ ○ △	—
N 0 to 20%	—	—	—	—	—	—	—	—	—	⊗ ○ △	⊗ ○
W 0 to 40%	—	—	—	—	—	—	—	—	—	⊗ ○ △	⊗ ○ △
P 0 to 50%	—	—	—	—	—	—	—	—	—	—	⊗ ○ △
X 0 to 70%	—	—	—	—	—	—	—	—	—	—	⊗ ○ △
R 0 to 100%	—	—	—	—	—	—	—	—	—	—	⊗ ○ △

⊗ : CO₂ ○ : CO △ : CH₄ □ : SO₂ — : Impossible

* Also single range is possible

(2) Dual-components (CO₂/CO)

1st component 1st range	2nd component 1st range	CO											
		E 0 to 500ppm	F 0 to 1000ppm	G 0 to 2000ppm	H 0 to 5000ppm	J 0 to 1%	K 0 to 2%	L 0 to 5%	M 0 to 10%	N 0 to 20%	V 0 to 25%	P 0 to 50%	R 0 to 100%
CO ₂	H 0 to 5000 ppm	—	○	○	○	○	○	○	○	○	○	○	○
	J 0 to 1%	○	○	○	○	○	○	○	○	○	○	○	○
	K 0 to 2%	○	○	○	○	○	○	○	○	○	○	*○	○
	L 0 to 5%	○	○	○	○	○	○	○	○	○	○	○	○
	M 0 to 10%	○	○	○	○	○	○	○	○	○	○	○	○
	N 0 to 20%	○	○	○	○	○	○	○	○	○	○	○	○
	P 0 to 50%	○	○	○	○	○	○	○	○	○	○	○	○
	R 0 to 100%	○	○	○	○	○	○	○	○	○	○	○	○

1st component is CO₂, 2nd component is CO.

○ : Dual-components are possible
Both components are able to have 2nd range.
2nd range is x 2 or x 2.5 of 1st range, choose the Code symbols

*○ : Dual-components are possible
But only one component, CO₂ or CO, is able to have 2nd range. 2nd range is x 2 or x 2.5 of 1st range, choose the Code Symbols.
— : Impossible.

FUNDAMENTAL PRINCIPLE DIAGRAM

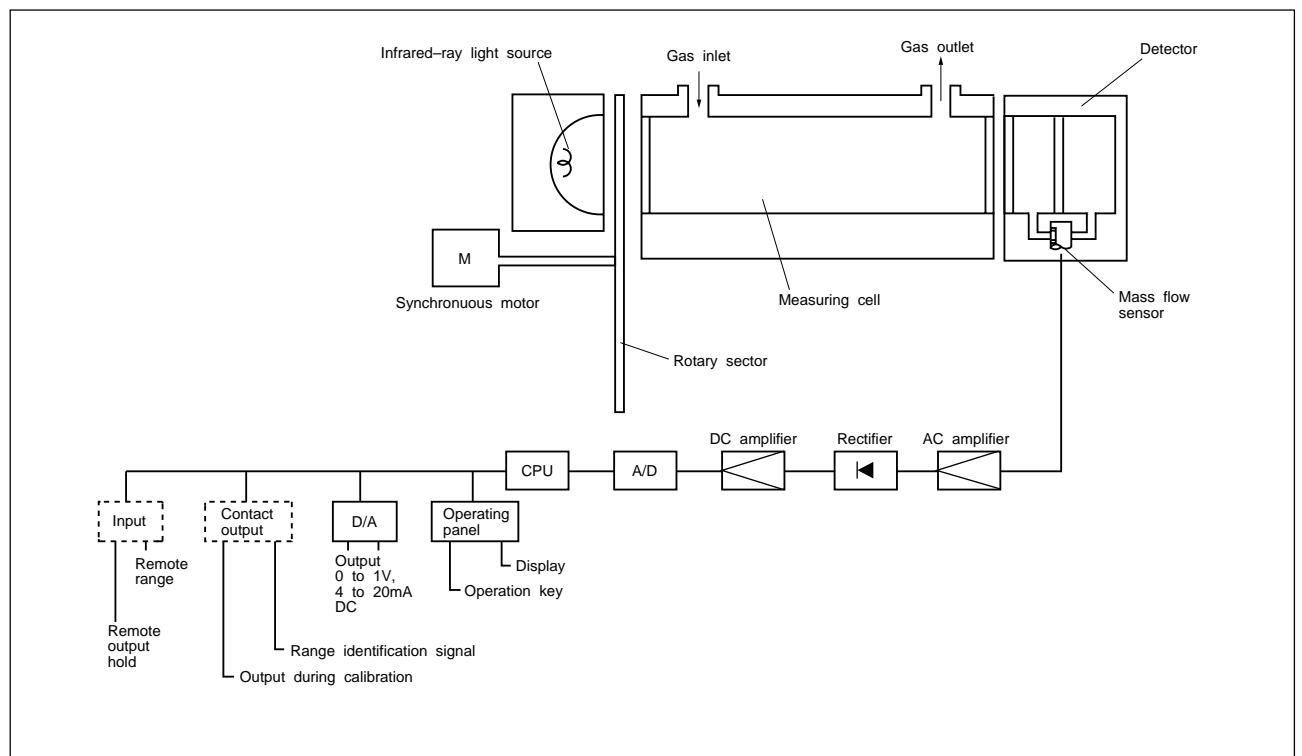

OUTLINE DIAGRAM (Unit:mm)

(1) Horizontal case

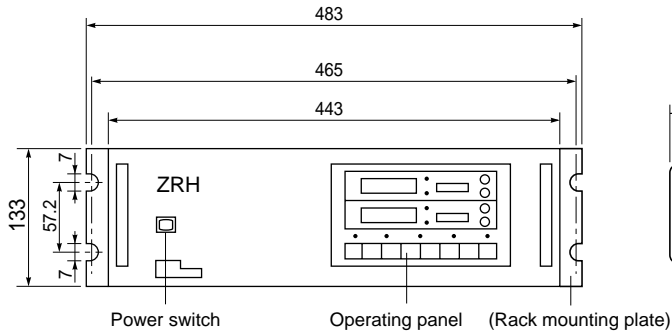

<Front View>

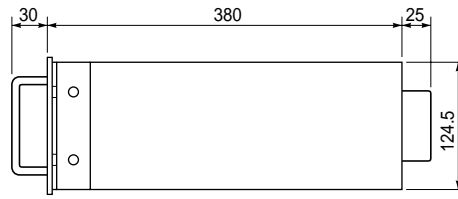

<Side View>

Panel cutout dimensions
(in case of panel mounting)

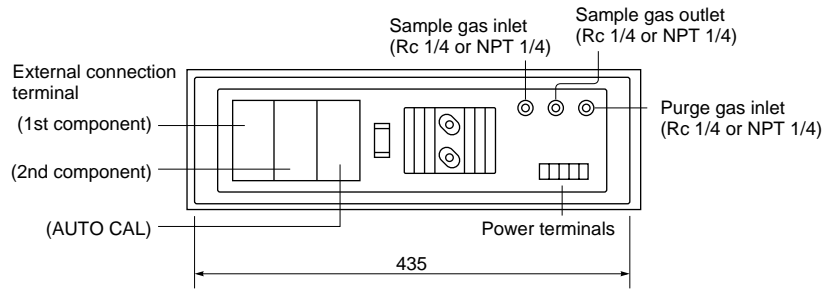
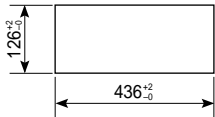

<Rear View>

(2) Vertical case

Panel flush mounting

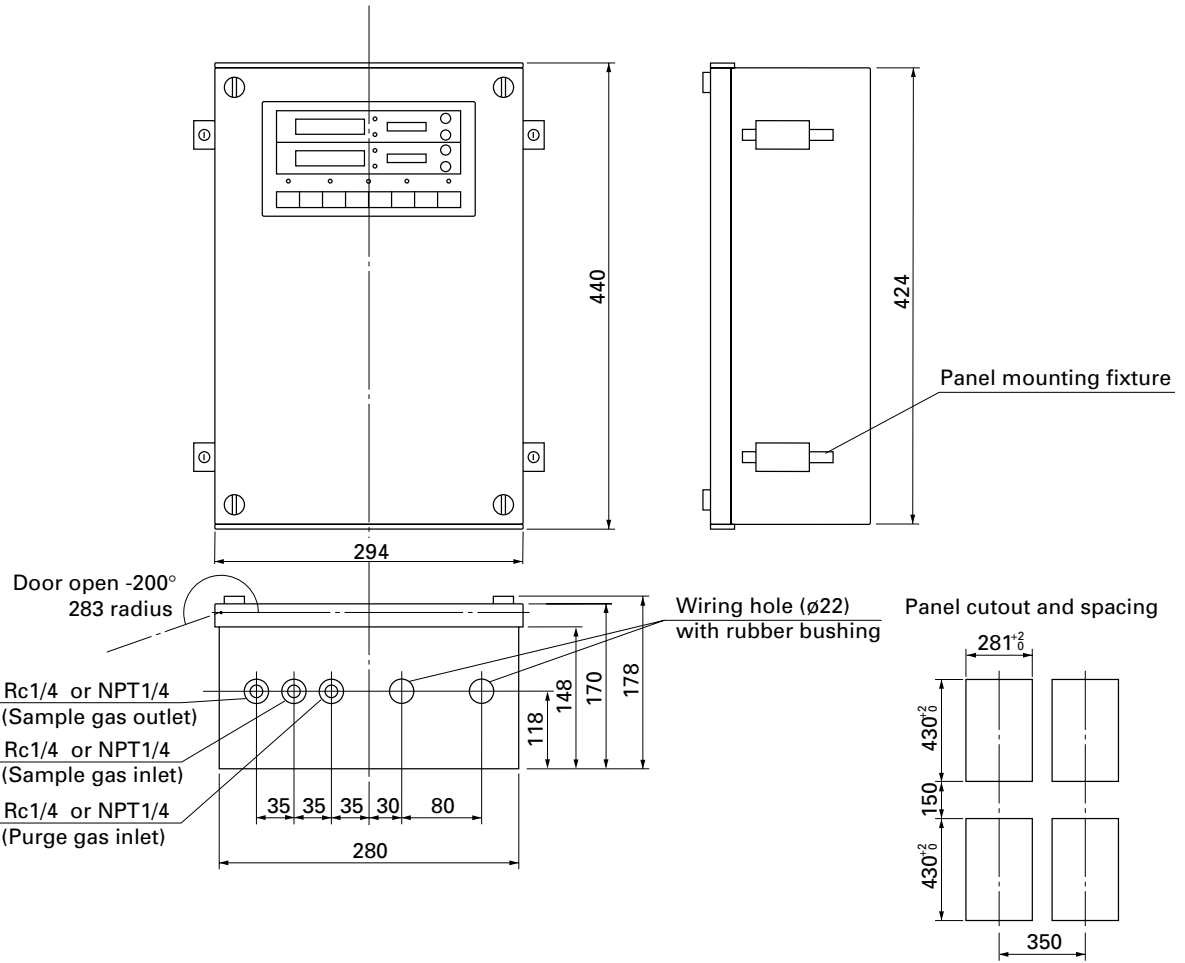

Wall mounting

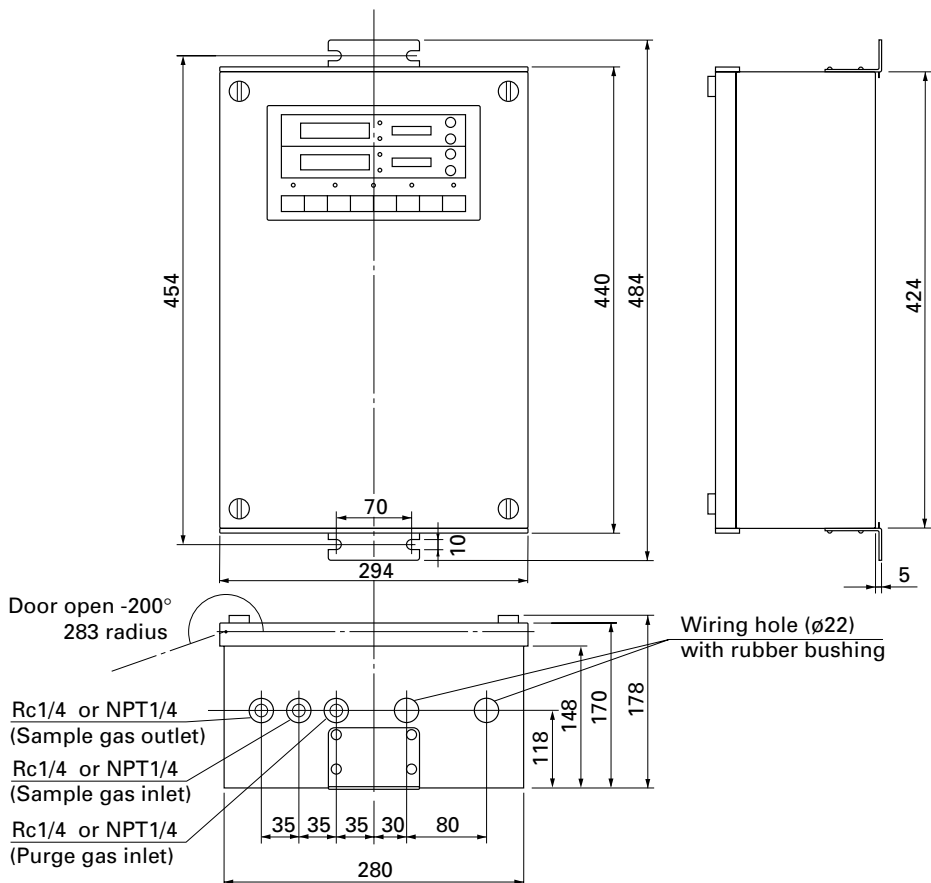

CONNECTION DIAGRAM (Same for horizontal and vertical cases)

M4 screws used

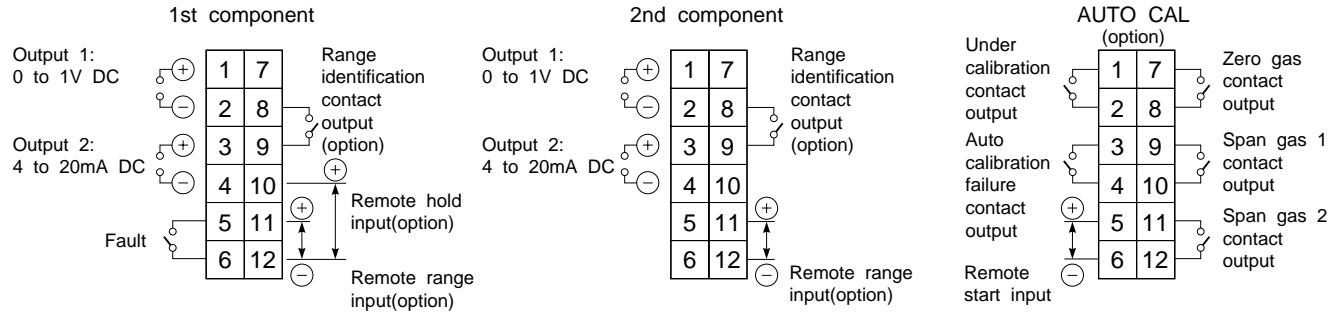

SCOPE OF DELIVERY

- 1 x gas analyzer main unit
- 1 x test report
- 1 x instruction manual
- 2 x Power fuse
- 4 x panel mounting bracket

ORDERING INFORMATION

1. Analyzer type.
2. Maximum, normal and minimum concentrations of sample gas as well as type and content (percent by volume) of concomitant gas.
3. Temperatures (maximum, normal and minimum), pressure and humidity of sample gas.
4. Dust conditions (mg/Nm³ or particle size, characteristics, etc.) and environmental conditions.
5. Other items

RELATED DEVICES

- Gas sampling device
- Accommodating locker
- Standard gas (for calibration)
- Receiving instrument

⚠ Caution on Safety

*Before using this product, be sure to read its instruction manual in advance.

Fuji Electric Systems Co., Ltd.

Head Office

Gate City Ohsaki, East Tower, 11-2, Osaki 1-chome, Shinagawa-ku, Tokyo 141-0032, Japan

<http://www.fesys.co.jp/eng>

Instrumentation Div.

International Sales Dept.

No.1, Fuji-machi, Hino-city, Tokyo, 191-8502 Japan

Phone: 81-42-585-6201, 6202 Fax: 81-42-585-6187

<http://www.fic-net.jp/eng>