

IN-SITU ZIRCONIA OXYGEN ANALYZER

DATA SHEET

ZSB

This oxygen analyzer is used to continuously measure oxygen concentration in combustion exhaust gas of industrial boilers or furnaces, and is ideally suited for combustion monitoring and control.

The analyzer consists of a flow guide tube with a detector, which is directly inserted into a flue, etc. to introduce the gas to be analyzed, a transducer, which performs control, signal processing, display, input to and output from outside, and communication, and an auto calibration/blow unit. The detector of a unit sensor structure facilitates on-site maintenance. The transducer provided with an unconventional sensor diagnostic function and sensor renewal function ensures long-term stable detecting operation.

FEATURES

1. No need for gas sampling devices

Since the sensor unit is directly inserted into a flue, etc., gas-sampling devices such as gas aspirator and dehumidifier are not required, which ensures high response speed.

2. Easy maintenance

The sensor in a unit structure mounted to the detector can be replaced easily. Since the detector and the flow guide tube are installed separately, the filter at the tip of the detector can be replaced easily, and detector and the flow guide tube can be maintained separately depending on the degree of formation of rust, for example.

3. High reliability ensured by the sensor diagnostic and sensor renewal functions

Depending on the components in the gas to be measured, the sensor electrode may degrade. The transducer diagnoses the degree of degradation of the sensor and renews it electrically, thus ensuring high reliability and long-term stable measurement.

4. Improved safety

Detecting a break of the thermocouple for heater control installed at the sensor, power supply to the detector is stopped. Furthermore, external contact input stops power supply to the detector in an emergency. Those functions along with the key lock function are equipped as standard to ensure improved safety.

5. Simple operation

The transducer can be operated and various settings can be made using an interactive system, and display language is available in English, Japanese, and Chinese.



SPECIFICATIONS

General

Measuring object: Oxygen in noncombustible gas

Measuring method:

Directly insert type zirconia system

Measuring range: 0 to 2 ...Setting range at option 2 in 50 vol% O₂ (in 1 vol% O₂ steps)

Repeatability: Within $\pm 0.5\%$ FS

Linearity: Within $\pm 2\%$ FS

Response time: Within 4 to 7 sec, for 90% (from calibration gas inlet)

Warmup time: More than 10 min.

Analog output: 4 to 20mA DC (allowable load resistance 500 Ω or less) or 0 to 1V DC (output resistance more 100 Ω or more)

Power supply: Rated voltage; 100 to 120V AC (operating voltage 90 to 132V AC)
Rated frequency; 50/60Hz

Power consumption:

Maximum 240VA (Detector: approx. 200VA, Converter: approx. 40VA)
Normal 70VA (Detector: approx. 50VA, Converter: approx. 20VA)

Material:

Steel plates (main frame)

Outer dimensions (H x W x D):

Wall-mounting type:
700 X 400 X 180mm
Self-standing type:
1500 X 530 X 550mm

Mass:

Wall-mounting type:
Approx. 27 kg (excluding cable, detector and standard gas)
Self-standing type:
Approx. 48 kg (excluding cable, detector and standard gas)

Finish color:

Munsell 5Y7/1, semi-gloss

Mounting method: Wall-mounting or self-standing**Detector (ZFK8)****Measured gas temperature:**

Flow guide tube system;
–20 to +600°C (for general-use, corrosive gas)

Measured gas pressure:

–3 to +3kPa

Flow guide tube:

- With or without blowdown nozzle
Flange; JIS5K 65A FF
Insertion length; 0.3, 0.5, 0.75, 1m
- For high particulate gas (with blowdown nozzle)
With or without cover
Flange; JIS5K 80A FF
Insertion length; 0.3, 0.5, 0.75, 1m

Operating temperature:

–10 to +60°C for Primary detecting element
–5 to +100°C for detector
125°C or less at detector flange surface with power applied

Storage temperature:

–20 to +70°C

Structure:

Dust/rain-proof structure (IEC IP66 equivalent, except the filter part at the tip)
Use a heat insulation cover in cold climates (as specified)

Filter:

Alumina (filtering accuracy 50 μ m) and quartz paper

Main materials of gas-contacting parts:

Zirconia, SCS14 (SUS316 equivalent), platinum, SUS304

Calibration gas inlet:

ϕ 6mm tube join

Reference air inlet: ϕ 6mm tube join**Detector mounting:**

Horizontal plane \pm 45°, ambient air should be clean.

Outer dimensions (L x max. dia.):

210mm x 100mm

Mass:

Approx. 1.6kg

Finish color:

Silver and SUS metallic color

Calibration gas flow:

1.5 to 2 L/min

Blowdown air inlet pressure:

200 to 300kPa

Converter (ZKM3)**Concentration value indication:**

Digital indication in 4 digits

Contact output signal:

- (1) Contact specification;
6 points,
1a 250V AC/3A or 30V DC/3A
- (2) Contact function;
 - Under maintenance
 - Instrument anomalies ^{Note1)}
 - Alarm ^{Note2)}
 - Zero calibration gas valve
 - Span calibration gas valve
 - Under blowdown ^{Note3)}

Note1) The following Instrument errors

- (1) Thermocouples break
- (2) Sensor break
- (3) Temperature fault
- (4) Calibration fault
- (5) Zero/span fault
- (6) Output error the contact ON

Note2) Alarm selects just one as mentioned below (1) High (2) Low (3) H/L (4) HH (5) LL, it turns ON while operating.

Note3) Under blow down, it is available in case of option, and it turns ON while operating.

Contact input signal:

- (1) Contact specification;
3 points (the following option)
ON; 0V (10mA or less), OFF; 5V
- (2) Contact function;
 - External hold
 - Calculation reset
 - Heater OFF
 - Blow down (option)
 - Inhibition of calibration
 - Calibration start
 - Range change

Calibration method:

- (a) Manual calibration with key operation
- (b) Auto. calibration (option)
Calibration cycle; 00 day 00 hour to 99 days 23 hours
- (c) All calibration

Calibration gas:

- Settable range
Zero gas; 0.010 to 25.00% O₂
Span gas; 0.010 to 50.00% O₂
- Recommended calibration gas concentration
Zero gas; 0.25 to 2.0% O₂
Span gas; 20.6 to 21.0% O₂ (oxygen concentration in the air)

Blowdown: A function for blowing out dust with compressed air that has deposited in the flow guide tube. Blowdown can be performed only for a pre-determined time and at pre-determined intervals.

Blowdown cycle;
00 hour 00 minute
to 99 hours 59 minutes

Blowdown time;
0 minute 00 second
to 0 minutes 999 seconds

Output signal hold: Output signal is held during manual/auto calibration, blowdown, sensor recovery processing, warm-up, PID auto tuning, and while maintenance mode setting is "available". The hold function can also be released.

Communication function:

RS232C (MODBUS) standard specification
RS485 (MODBUS) (option)

Combustion efficiency display:

When you select this display, "rich mode display" will be simultaneously displayed.

This function calculates and displays combustion efficiency from oxygen concentration and measured gas temperature.

Thermocouple (R) is required for temperature measurement.

Operating temperature:

-20 to +55°C

Operating humidity:

95% RH or less, non condensing

Storage temperature:

-30 to +70°C

Storage humidity: 95% RH or less, non condensing

Outer dimensions (H × W × D):

182 × 163.5 × 70.6mm

Mass:

Approx. 2kg (excluding cable and detector) (IP66)

Mounting method: Mounted flush on panel

CODE SYMBOLS

1	2	3	4	5	6	7	8	9	10	11	12	13	14	15	Description
Z	S	B					2								
4th digit			1	Converter mounting (4th digit)											
			2	Wall-mounting type (with indication window)											
				Self-stand type (with indication window)											
5th digit			A	Sensor, Power supply, Cal. Gas inlet (5th digit)											
			B	For general use without protection cover, 100/115 V AC, 50/60 Hz and inlet for $\phi 6$ mm tube											
				For general use with protection cover, 100/115 V AC, 50/60 Hz and inlet for $\phi 6$ mm tube											
				* Protection cover should be selected when ambient temperature is -10°C or lower.											
6th digit			Y	Sensor cable + calibration gas tube (6th digit)											
			A	None											
			B	6 m cable (without conduit) + 6 m Teflon tube ($\phi 6/\phi 4$)											
			C	10 m cable (without conduit) + 10 m Teflon tube ($\phi 6/\phi 4$)											
			D	15 m cable (without conduit) + 15 m Teflon tube ($\phi 6/\phi 4$)											
			E	20 m cable (without conduit) + 20 m Teflon tube ($\phi 6/\phi 4$)											
			F	6 m cable (with conduit) + 6 m Teflon tube ($\phi 6/\phi 4$)											
			G	10 m cable (with conduit) + 10 m Teflon tube ($\phi 6/\phi 4$)											
			H	15 m cable (with conduit) + 15 m Teflon tube ($\phi 6/\phi 4$)											
			J	20 m cable (with conduit) + 20 m Teflon tube ($\phi 6/\phi 4$)											
			K	6 m cable (4-core cable only. Heater cable should be prepared by customer.) + 6 m Teflon tube ($\phi 6/\phi 4$)											
			L	10 m cable (4-core cable only. Heater cable should be prepared by customer.) + 10 m Teflon tube ($\phi 6/\phi 4$)											
			M	15 m cable (4-core cable only. Heater cable should be prepared by customer.) + 15 m Teflon tube ($\phi 6/\phi 4$)											
				20 m cable (4-core cable only. Heater cable should be prepared by customer.) + 20 m Teflon tube ($\phi 6/\phi 4$)											
				* When exclusive-special conduit and heater cable are not used, the following conduit should be used. Conduit with outer diameter $\phi 23$ and inner diameter $\phi 16$ as specified in JIS C8411 For preparing two heater cables, their rating should be 3 A or more.											
7th digit			1	Calibration gas unit (7th digit)											
			2	Automatic calibration unit + zero gas + filter regulator											
			3	Automatic calibration unit + zero gas + air standard gas											
			4	Manual calibration unit + zero gas + filter regulator											
				Manual calibration unit + zero gas + air standard gas											
9th, 10th, 11th digits			0	Y	0	Flow guide tube (9th, 10th and 11th digit)									
			5	A	3	(Flange)	(Application)	(Length)	(Note)						
			5	A	5	SUS304	For general use	300mm							
			5	A	7	SUS304	For general use	500mm							
			5	A	1	SUS304	For general use	750mm							
			5	B	3	SUS316	For general use	1000mm							
			5	B	5	SUS316	For corrosive	300mm							
			5	B	7	SUS316	For corrosive	500mm							
			5	B	1	SUS316	For corrosive	750mm							
			6	D	3	SUS316	For corrosive	1000mm							
			6	D	5	SUS316	Without high particulate cover	300mm	With blow-back unit						
			6	D	7	SUS316	Without high particulate cover	500mm	With blow-back unit						
			6	D	1	SUS316	Without high particulate cover	750mm	With blow-back unit						
			Z	Z	Z	Others	Without high particulate cover	1000mm	With blow-back unit						
			Z	Z	Z	Others	Others	Others							
12th digit			B	Output signal (12th digit)											
			E	4 to 20mA DC											
				0 to 1V DC											
13th digit			J	Language (13th digit)											
			E	Japanese											
			C	English											
				Chinese											
14th digit			1	Communication functions (14th digit)											
			2	RS232											
				RS485											
15th digit			Y	Reference gas (15th digit)											
			1	None											
				$\phi 6$ mm tube joint											

DEVICE CONFIGURATION

The device to be combined differs according to the conditions of the gas to be measured. Please select the flow guide tube, referring to the table shown below.

Measured gas					Device configuration	
Application	Temperature	Gas Flow	Dust	Note	Type at 4th to 7th digits	Flow guide tube at 9th to 11th digits
Boiler, refuse incinerator, sludge incinerator, etc.	600°C or less	5 to 20m/s	Less than 0.2g/Nm ³	For boiler. Fuel; gas, oil	ZSB□□□□2-	5A□
			Less than 1g/Nm ³	When moisture content in measured gas is low.	ZSB□□□□2-	5B□
			Less than 25g/Nm ³	When moisture content in measured gas is low. With blow-down	ZSB□□□□2-	6D□

Note (1) Dust volume is approximate value.

(2) Reference air port specification should be selected when standard gas concentration changes.

(3) For optional specifications, contact the manufacturer separately.

SCOPE OF DELIVERY

1) Standard delivery

- 1 set x zirconia oxygen analyzer
- 1 set x instruction manual
- 1 set x standard accessories
 - 1 x O-ring (for detector)
 - 1 x ceramic filter (for detector)
 - 2 each x fuse (3.15 A, 0. 5 A)
 - 1 set x inlet (for standard gas connection)
 - 1 x polyethylene tube (for standard gas connection)
 - 1 x Toaron tube (for standard gas connection)
 - 1 set x flow guide tube accessories (bolt, nut, spring washer x 4 pieces each)

2) Items to be prepared separately

- Replacement detector
- Spare (detector)
- Spares for 1-year operation
 - 1 x O-ring
 - 2 x ceramic filter
 - 1 x Filter frame
- Spares for 2-year operation
 - 2 x O-ring
 - 4 x ceramic filter
 - 2 x Filter frame

CAUTIONS

- If combustible gas (CO, H₂ etc.) exists in the measured gas, error will occur due to burning at the sensor section. The inclusion of corrosive gas (Si vapor, alkaline metal, P, Pb etc.) will shorten the life of the sensor.
- When the measured gas temperature is high (+300°C or higher), the flange should be separated from the furnace wall in order to bring the detector flange surface temperature below the specified value (+125°C). The flow guide tube should be attached in the direction in which the gas flow to the detector decreases.
- If much dust is contained in the gas, the flow guide tube should be connected obliquely from the top. This tube should also be connected in the direction where gas flow into the detector section is reduced.
- In application to refuse incineration, automatic blow-down of the flow guide tube should be avoided (in order to protect the tube from corrosion due to drain formation). Blow-down should be carried out manually when indication change becomes small during stop of the incinerator.

CONFIGURATION

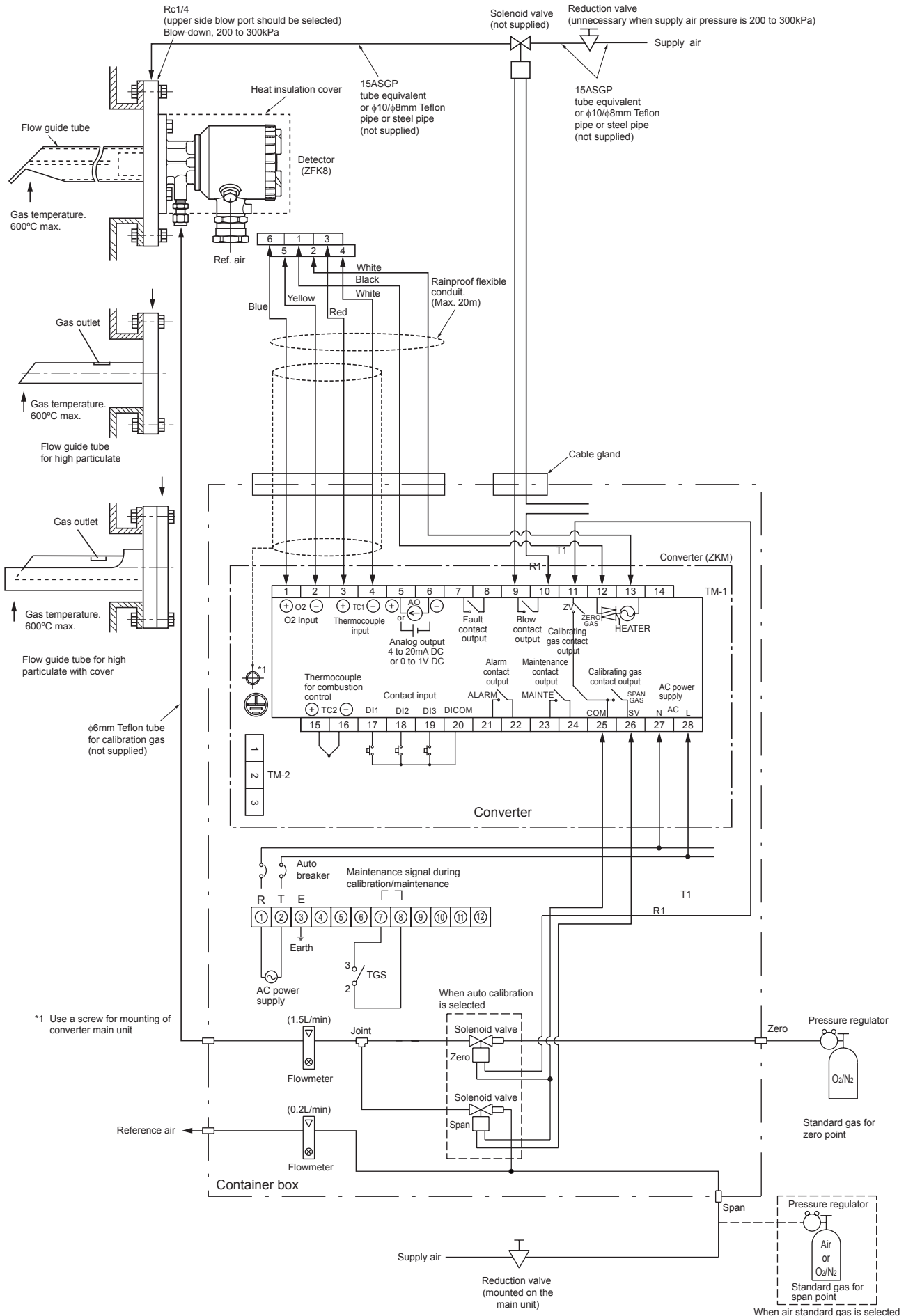

OUTLINE DIAGRAM (Unit : mm)

Self-standing type: ZSB2

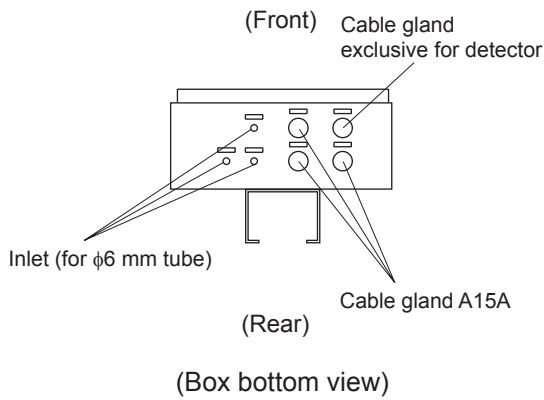
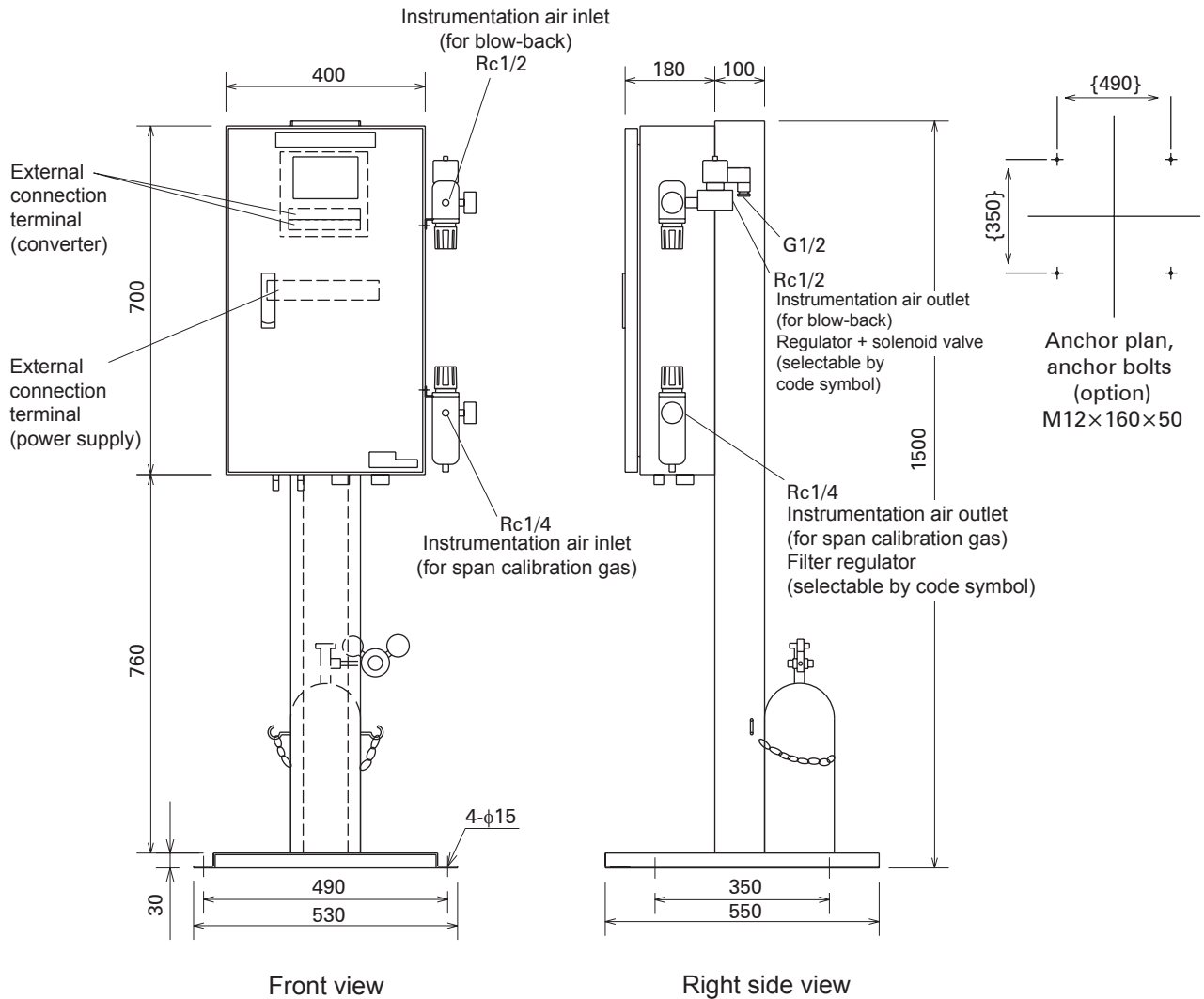

EXTERNAL CONNECTION DIAGRAM (POWER SUPPLY)

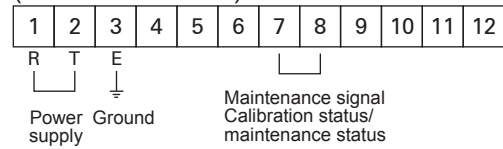

Wall-mounting type: ZSB2

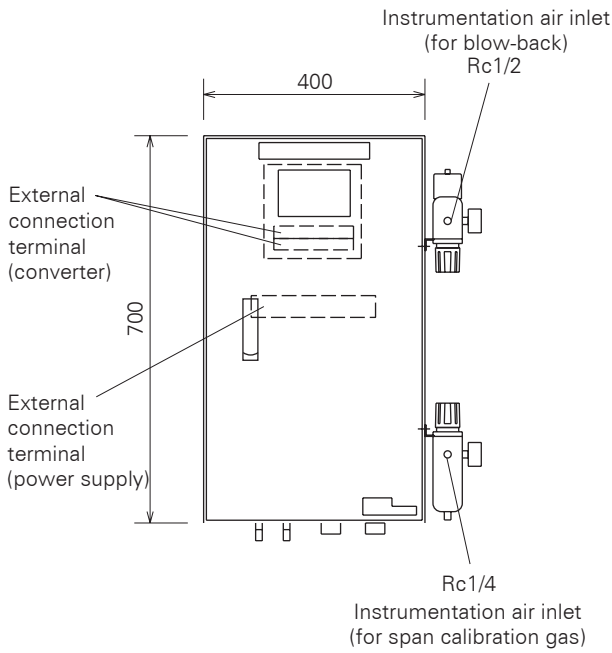

Front view

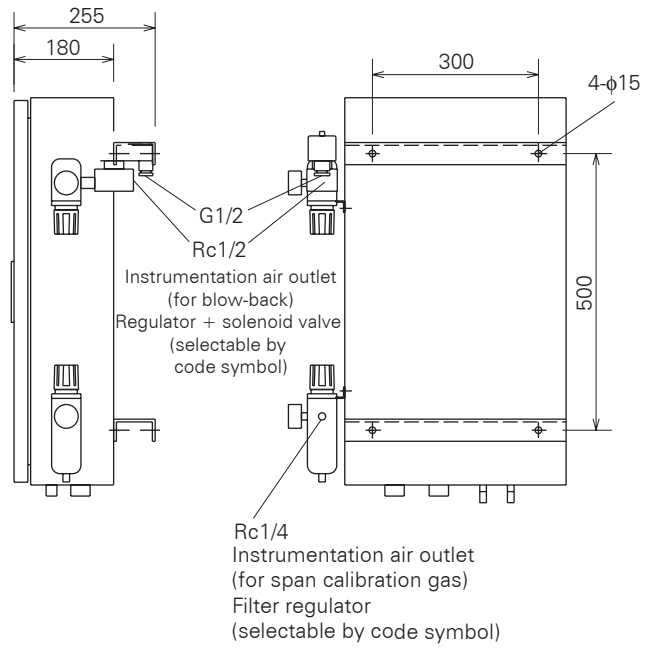

Right side view

Rear view

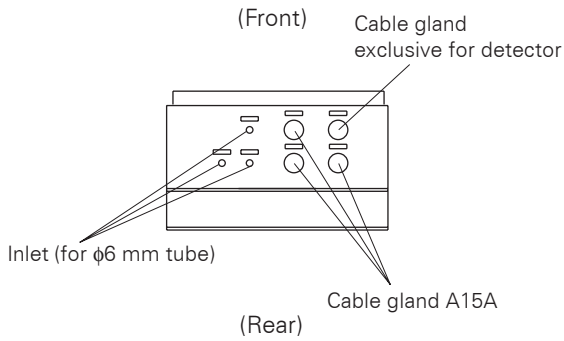

(Box bottom view)

EXTERNAL CONNECTION DIAGRAM (POWER SUPPLY)

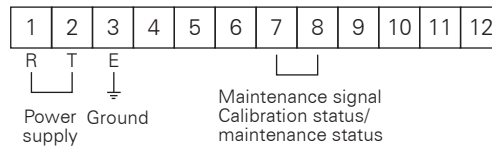

Converter: ZKM3

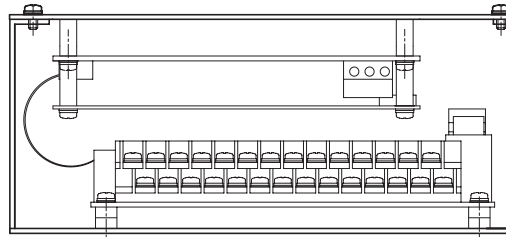
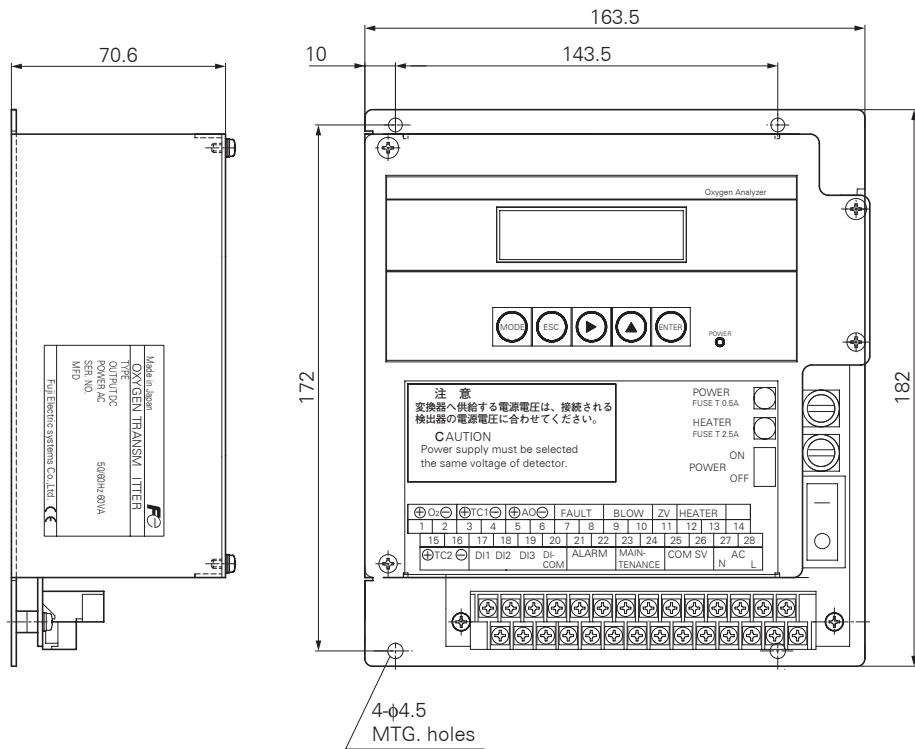

External terminal (TM1)

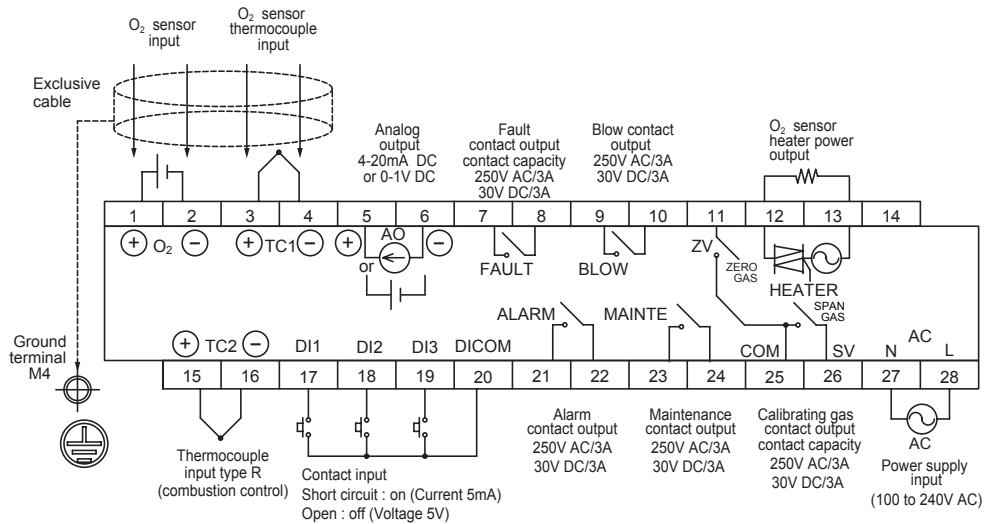

COMMUNICATION TERMINAL (TM2) /INSERTION TERMINAL

	Terminal number			Remarks
	1	2	3	
RS232C	TXD	RXD	GND	Standard
RS485	TRX+	TRX-	GND	Option

Detector: ZFK8

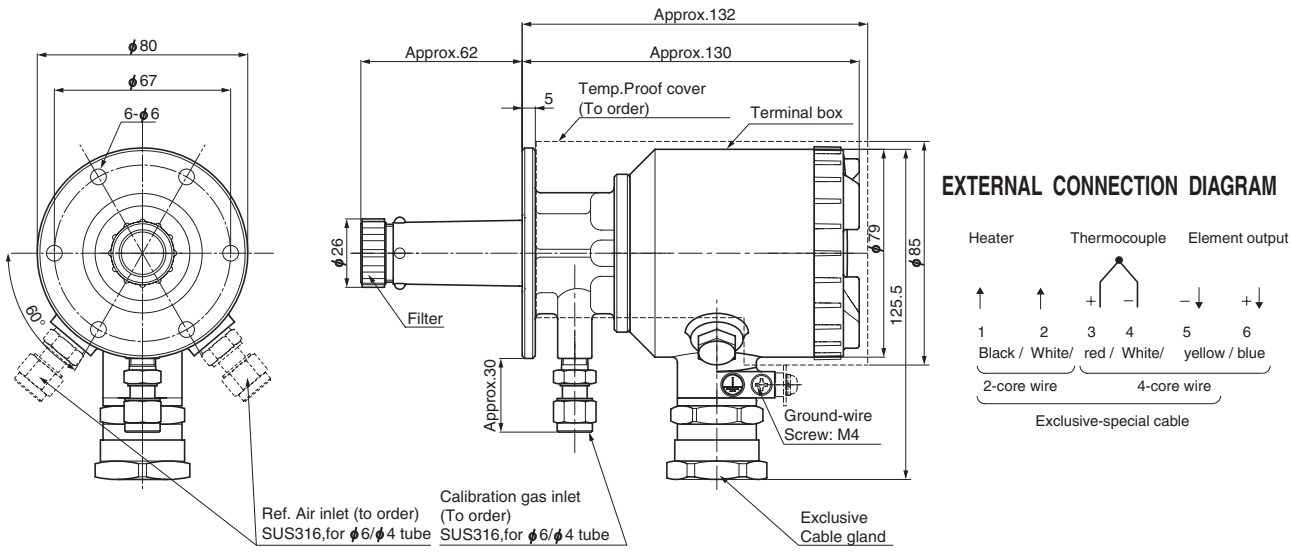

EXTERNAL CONNECTION DIAGRAM

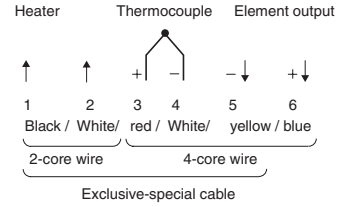

Replacement Detector element

Sensor unit (ZFK8YY)

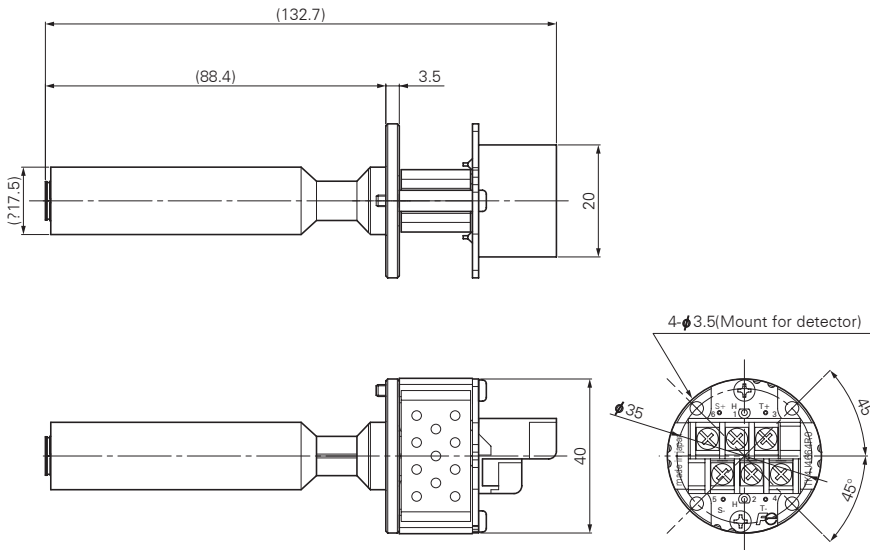

Flow guide tube (for general-use)

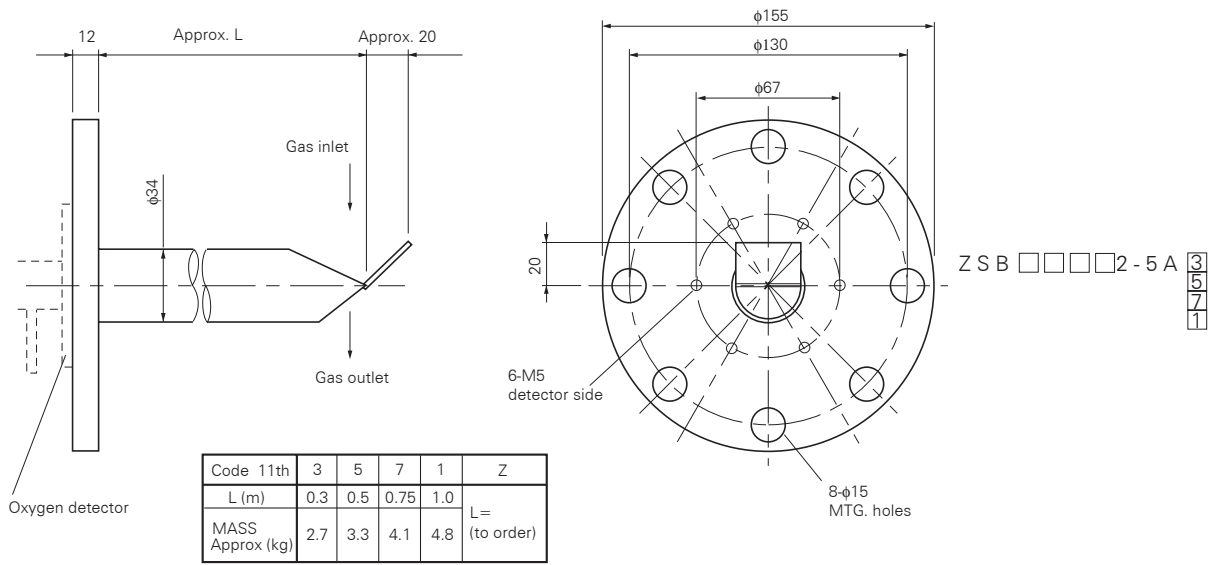

Flow guide tube (for corrosive gas)

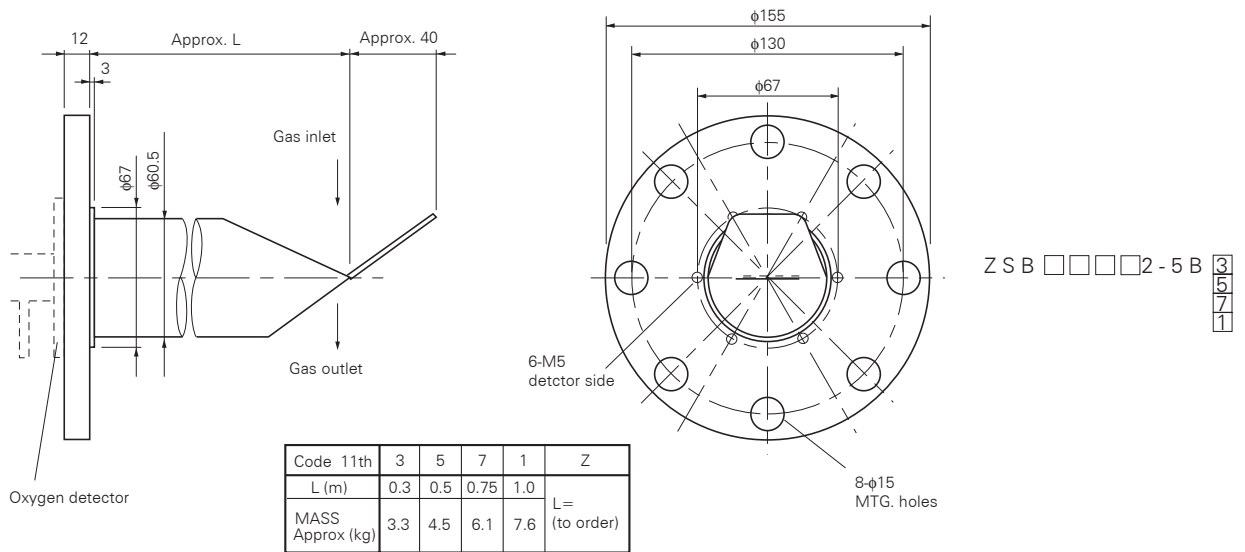

Flow guide tube (for high particulate)

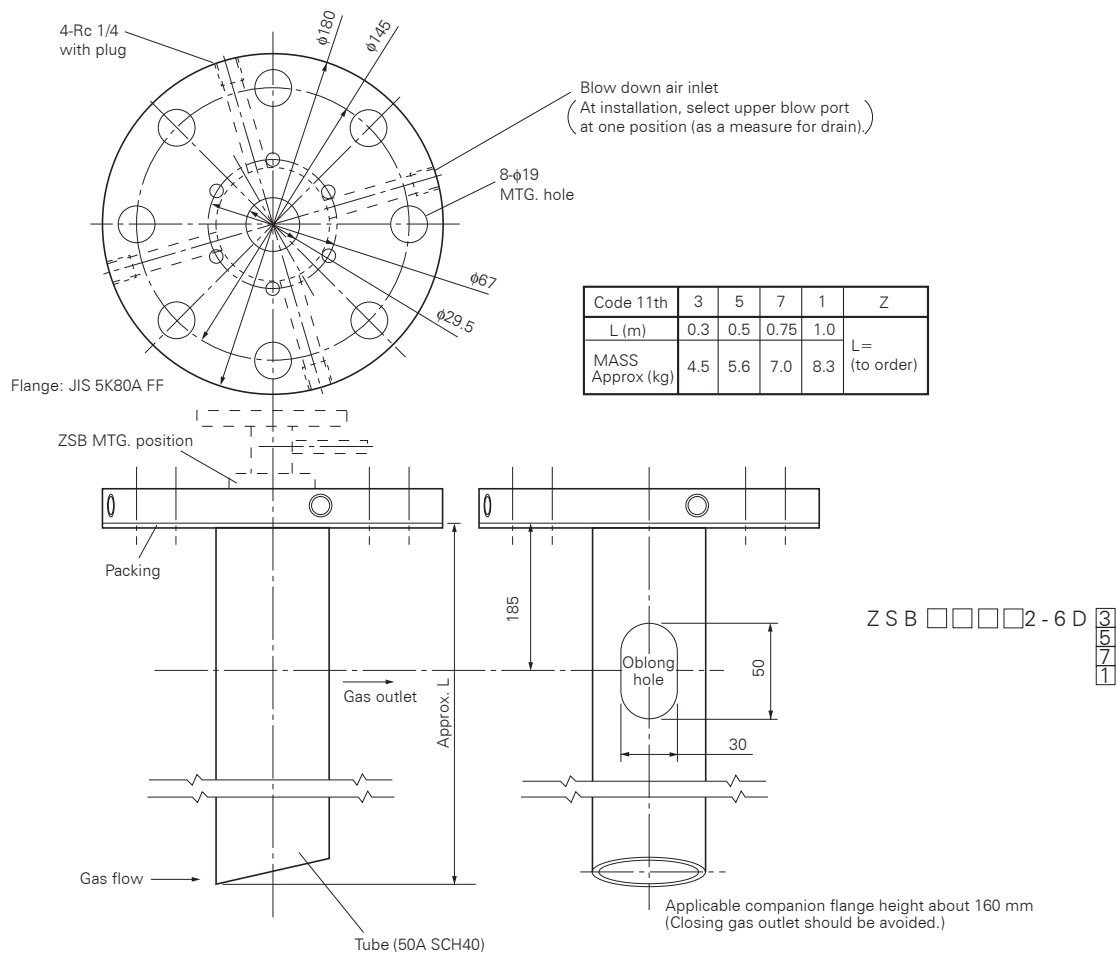

⚠ Caution on Safety

*Before using this product, be sure to read its instruction manual in advance.

Fuji Electric Systems Co., Ltd.

International Sales Div.5

Sales Group

Gate City Ohsaki, East Tower, 11-2, Osaki 1-chome, Shinagawa-ku, Tokyo 141-0032, Japan

<http://www.fesys.co.jp/eng>

Phone: 81-3-5435-7280, 7281 Fax: 81-3-5435-7425

<http://www.fic-net.jp/eng>