

COMPACT TYPE GAS ANALYZER

DATA SHEET

ZSVS

OVERVIEW

The compact type gas analyzer with built-in pump and filter is intended for heat treat furnace, plant cultivation, and research-purpose chemical analysis. With the gas extractor, either simplified measurement probe (non-fixed type) or continuous measurement probe (fixed type) is selectable at option. Since a high-sensitivity single-beam mass flow controller is adopted for the infrared sensor, long-term stability and maintainability are excellent.

FEATURES

1. Gas concentrations of 4 components measurable simultaneously and continuously (Note). Concentrations of max. 3 gas components among CO₂, CO and CH₄ are continuously measurable with the infrared sensor, and that of O₂ is continuously measurable with galvanic cell type oxygen sensor.
2. Standard with 3-range analyzer
Measurement can be performed over a broad range using the range selector key.
3. Compact type small and easy to use.
The compact body with built-in pump and membrane filter is easy to carry and install.
Operation is easier because operation keys and display unit are all gathered in the analyzing block.
4. A rich variety of standard functions incorporated.
Max. 8-channel outputs are allowed including instantaneous concentration value, O₂-corrected value, O₂-corrected moving average value and CP calculation value outputs.

(Note) For continuous measurement, the standard requirements for sample gas (shown on page 3) need to be met, and zero/span calibrations and membrane filter replacement are required periodically.

SPECIFICATIONS

Standard Specifications

- Measuring system:
 - CO₂, CO and CH₄; Non-dispersive infrared absorption method with single light source and single beam (single beam method)
 - O₂; Galvanic cell method



- Measurable component and min./max. measuring range:
 - CO₂; 0 to 200 ppm / 0 to 100 %
 - CO; 0 to 200 ppm / 0 to 100 %
 - CH₄; 0 to 1000 ppm / 0 to 100 %
 - O₂; 0 to 5 % / 0 to 25 %
 - Max. 4 components measurable including O₂
- Number of measuring ranges:
 - 3 ranges
 - Max. range ratio 1:5
- Warm-up time: 30 min after power-on
Provided with count-down timer indicating function.
- Analog output: In up to 8 channels.
4 to 20 mA DC or 0 to 1 V DC (linear)
Non-isolated output
Allowable load; 4 to 20 mA DC, 550Ω or less
0 to 1 V DC, 100 kΩ or more
 - Instantaneous value output of each gas component
 - Instantaneous value output after O₂ correction (when provided with O₂ analyzer)
 - Average value output after O₂ correction (when provided with O₂ analyzer)
 - CP calculation value output (when provided with CO₂ analyzer)
 - * The channel numbers of indicated value and output value correspond to each other one by one.
 - * An exclusive 25-pin cable is standard-equipped.
- Communication output:
 - RS-232C Modbus protocol
 - * Use a commercially available product (D-sub 9-pin cable).

This product is not explosion-proof. When handling dangerous gas, adequate attention shall be paid.

- **Indicated values:**
 - Digital 4-digit indication (by LCD with back light)
 - Instantaneous values of respective gas components
 - Instantaneous values after O₂ correction (when provided with O₂ analyzer)
 - Average value after O₂ correction (when provided with O₂ analyzer)
 - CP calculation value display (when provided with CO₂ analyzer)
 - * The channel numbers of indicated value and output value correspond to each other one by one.
- **Power supply:**
 - Rated voltage; 100 to 115 V AC or 200 to 240 V AC
 - Working voltage; 85 to 132 V AC or 180 to 264 V AC
 - * Depending on customer's code selection.
 - Rated frequency; 50/60 Hz
 - Max. rated power; 150 VA
 - Inlet; Class 1 type conforming with EN60320
- **Operating conditions:**
 - Ambient temperature; 0 to 40°C
 - Ambient humidity; 90% RH or less
 - * Condensation unallowable
- **Storage conditions:**
 - Ambient temperature; -20 to 60°C
 - Ambient humidity; 95% RH or less
 - * Condensation unallowable.
- **External dimensions (H × W × D mm):**
 - 211 × 365 × 527
- **Weight:**
 - Approx. 12 kg
- **Finish color:**
 - Cover; White pearl mica
 - Base; Medium gray metallic
- **Enclosure design:**
 - Casing made of steel plates for indoor installation.
- **Gas-contacting part materials:**
 - Gas inlet/outlet; Polypropylene
 - Sample cell; SUS304/neoprene rubber
 - Transparent window; CaF₂
 - Internal pipes; Toalon tube/Teflon tube
- **Gas inlet/outlet:** φ6/φ3 hose end
- **Purge gas flow rate:**
 - 1 L/min (to be purged as required)

Standard Functions

- **Zero gas flow time:**
 - Z180 to 999 sec (settable in 1-sec step)
- **Auto indication off:**
 - Indication automatically turns off when no key is operated for the determined period of time in the standby status.
 - Light off time; OFF/ON (1 to 30 min) (settable in 1-min step)
- **Output holding:** At calibration during measurement, output holds the value just before the calibration according to hold setting. In the standby status, output will not be held. Indication will not be held either.
 - Hold setting; OFF/ON
- **Key lock:**
 - None of the set values can be changed when key lock is turned ON.
 - This is helpful for reducing operation errors and wrong inputs.

- **Instrument/calibration error indication:**
 - When the instrument or calibration is abnormal, an error number is indicated to help analysis of the error.
- **O₂ correction:**
 - Conversion of measured NO_x, SO₂ and CO gas concentrations into values at standard O₂ concentration
 - Calculating equation;
$$C = \frac{21 - O_n}{21 - O_s} \times C_s$$
 - C; Sample gas concentration after O₂ correction
 - C_s; Measured concentration of sample gas
 - O_s; Measured O₂ concentration
 - O_n; Standard O₂ concentration for conversion (settable within 0 to 19%)
 - The result of conversion is indicated and output in a signal simultaneously.
 - * An O_s value of 20% or more is taken as 20% for calculation.
- **Averaging after O₂ correction;**
 - The result of O₂ correction is subjected to moving average for the determined period of time. And the result of averaging is indicated and output in a signal simultaneously.
 - Average value will be taken at a cycle of 30 sec. (Indication and output are updated every 30 sec.)
- **Resetting of output average value:**
 - Indication and output of average value are cleared in response to resetting.
 - * Effective only when average value selection is specified in CODE SYMBOLS.
- **CP calculation:** The carbon potential of carburizing furnace and conversion furnace are calculated using furnace temperature (fixed input value) and CO concentration value (fixed or measured value) while referring to CO₂ measured value.

Calculation equation; $CP = \frac{CPS \times (PCO)^2}{K1 \times PCO_2}$

where,

CPS ; Saturated carbon concentration (partial pressure)

0.0028t-1.30 (800°C ≤ 850°C)

0.0030t-1.47 (850°C ≤ 950°C)

0.0034t-1.85 (950°C ≤ 1000°C)

t ; Furnace temperature

PCO ; CO concentration value (partial pressure)

PCO₂ ; CO₂ concentration value (partial pressure)

K1 ; Constant K1=10 (9.06-15966/T)

T ; Rankine temperature (tx9/5+32+46°)

Performance

- **Repeatability:** Within $\pm 0.5\%$ of full scale
- **Linearity:** Within $\pm 2\%$ of full scale
- **Zero drift:** Within $\pm 1\%$ of full scale/day
- **Span drift:** Within $\pm 1\%$ of full scale/day
- **Response time:** 90% response time: Within 50 sec Galvanic cell type O₂ analyzer: Within 3 min
- **Other gases' influence:**

Interference component concentration	Sample component/range	CO ₂ analyzer		CO analyzer		O ₂ analyzer	CH ₄ analyzer
		200ppm max	500ppm min	200ppm max	500ppm min	All ranges	All ranges
NO	1000ppm	Within $\pm 2\%$		Within $\pm 2\%$		Within $\pm 2\%$	Within $\pm 2\%$
SO ₂	1000ppm	Within $\pm 2\%$		Within $\pm 2\%$		Within $\pm 2\%$	Within $\pm 2\%$
CO ₂	15%	—	—	Within $\pm 3\%$	Within $\pm 3\%$	Within $\pm 2\%$	Within $\pm 5\%$
CO	1000ppm	Within $\pm 2\%$		—	—	Within $\pm 2\%$	Within $\pm 2\%$
CH ₄	1000ppm	Within $\pm 2\%$		Within $\pm 2\%$		Within $\pm 2\%$	—
NH ₃	50ppm	Within $\pm 2\%$		Within $\pm 2\%$		Within $\pm 2\%$	Within $\pm 2\%$
H ₂ O 2°C saturatio		Within $\pm 3\%$	Within $\pm 2\%$	Within $\pm 3\%$	Within $\pm 2\%$	Within $\pm 2\%$	Within $\pm 2\%$

Standard Requirements for Sample Gas

- **Flow rate:** 0.5 L/min \pm 0.2 L/min
- **Temperature:** 0 to 40°C at inlet of sampling gas
10 to 70°C at tip of non-fixed type probe (available at option)
70 to 400°C at tip of fixed type probe (available at option)
- **Pressure:** 0 to 2 kPa (Gas shall be discharged into atmospheric air.)
- **Dust:** 10 mg/Nm³ or less
- **Mist:** Unallowable
- **Corrosive gas:** HCl 10 ppm or less
Others Unallowable
- **Standard gas for calibration:**
Zero gas; N₂ or clean air
However, clean air cannot be used if CO₂ and O₂ are included in sample gas components.
Span gas; Concentration limited within 90 to 100% of the range of each sample gas component.
Unusable at concentrations beyond 100%.

Options

- **Gas extractor:** Used for aspirating sample gas.
Non-fixed type; Since this type is used for intermittent measurement, it cannot be fixed.
Material;
SUS304/polypropylene
Fixed type; Used for continuous measurement. Flange 5K25A FF
Sampling pipe length selectable among 300, 400, 600 and 800mm
Material; SUS316
- **Sample inlet tube:**
Used for delivering gas from the extractor to sampling block.
Shape; $\phi 6/\phi 4 \times 5$ m or $\phi 6/\phi 4 \times 10$ m
Material; Teflon

Installation Requirements

- Selection of a place which does not receive direct sunlight, rain, wind nor radiation from hot substances.
If such a place cannot be found, a roof or cover should be prepared for protection.
- Avoidance of a place under heavy vibration
- Selection of a place where atmospheric air is clean
- Discharge of exhaust gas into atmospheric air at a safe location
- Avoidance of use in an explosion-proof area

Scope of Delivery

- Gas analyzer system
- Standard accessories (Refer to the table at top Following table.)
- Instruction manual

Items to be Prepared Separately

- Standard gas (ZBM) and pressure regulator (ZBD)
- Recorder (when necessary, Fuji's product type PHR)

Standard Accessories

Name	Quantity
Tubular fuse (2A)(for analyzing block)	2 pcs
Power cord (for domestic use, for 100/115V AC) (2m) \times 2 Power cord (for North American use, for 100/115V AC) (2m) \times 2 Power cord (for European use, for 200/220V AC) (2m) \times 2	Either one pair * Depending on customer's code selection.
Grounding cable (5m)	1 cables
Output signal cable (1m)	1 cable
Filter paper (glass fiber) for membrane filter	5 sheets
Connection tube (5m)	1 tube
Instruction manual (in Japanese or English)	1 copy

Note) Standard accessories include consumables for 6 months.

Spare Parts for 1-Year Measurement

Name	Quantity	Ordering No.
Filter paper (glass fiber) for membrane filter	1 pc (25 sheets)	TK700735P2
Large O-ring for membrane filter	1 pc	8553765
Small O-ring for membrane filter	1 pc	TK733572P1
Diaphragm unit for pump	1 unit	TK713248P1

Specify the ordering No. and the quantity when placing an order.

Other

- A galvanic cell type oxygen sensor has a service life of about 18 months from the date of its delivery. Periodic replacement is recommended.
Replacement part ordering No. : TK7M3502C1

Principle Diagram of Infrared Type Measurement (CO₂, CO, CH₄)

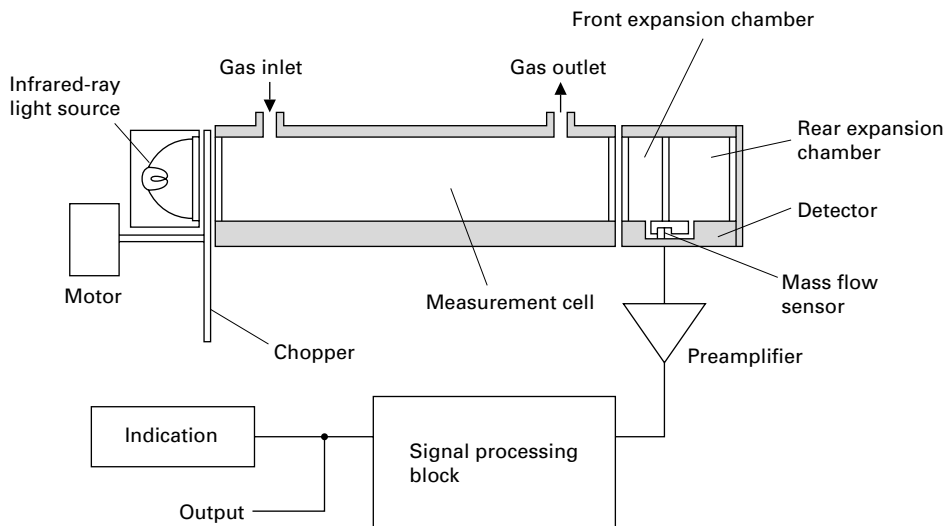

Principle Diagram of Galvanic Cell Type Measurement (O₂)

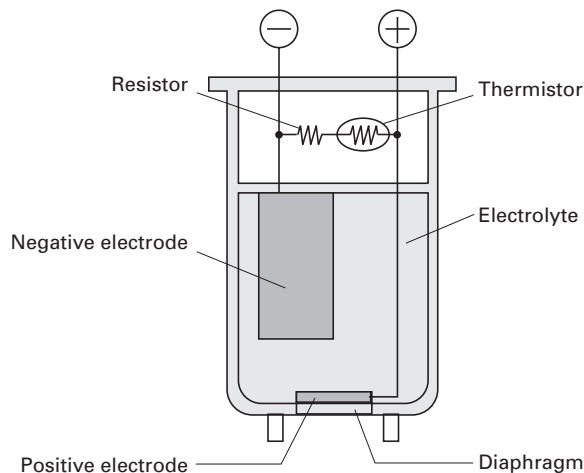

CODE SYMBOLS

Digit	Description	note	1	2	3	4	5	6	7	8	9	10	11	12	13	14	15	16	17	18	19	20	← Digit No. of code
4	< Specification > Analyzing block		Z	S	V	S				Y	1												
5	< Sample components (CO ₂ , CO, CH ₄) > 1-component analyzer CO CO ₂ CH ₄ 2-component analyzer (1st component + 2nd component) CO ₂ +CO CH ₄ +CO CO ₂ +CH ₄ 3-component analyzer (1st component + 2nd component + 3rd component) CH ₄ +(CO ₂ +CO) With out Other	note 2					B	D	E														
6	< Sample component (O ₂) and measuring range > Galvanic cell type oxygen analyzer/0 to 5%/10%/25% With out								1														
8	< Revision code >									1													
9	< Power supply > For domestic use 100 to 115V AC, 50/60Hz For European use 200 to 240V AC, 50/60Hz For North American use 100 to 115V AC, 50/60Hz	note 3										1	2	3									
10	< Measuring range (1st component) > 0 to 200ppm/500ppm/1000ppm 0 to 500ppm/1000ppm/2000ppm 0 to 1000ppm/2000ppm/5000ppm 0 to 2000ppm/5000ppm/1% 0 to 5000ppm/1%/2% 0 to 1%/2%/5% 0 to 2%/5%/10% 0 to 5%/10%/20% 0 to 10%/20%/50% 0 to 20%/50%/100% With out	note 2										A	B	C	D	E	F	G	H	J	K	Y	
11	< Measuring range (2nd component) > 0 to 200ppm/500ppm/1000ppm 0 to 500ppm/1000ppm/2000ppm 0 to 1000ppm/2000ppm/5000ppm 0 to 2000ppm/5000ppm/1% 0 to 5000ppm/1%/2% 0 to 1%/2%/5% 0 to 2%/5%/10% 0 to 5%/10%/20% 0 to 10%/20%/50% 0 to 20%/50%/100% With out	note 2											A	B	C	D	E	F	G	H	J	K	Y
12	< Measuring range (3rd component) > 0 to 200ppm/500ppm/1000ppm 0 to 500ppm/1000ppm/2000ppm 0 to 1000ppm/2000ppm/5000ppm 0 to 2000ppm/5000ppm/1% 0 to 5000ppm/1%/2% 0 to 1%/2%/5% 0 to 2%/5%/10% 0 to 5%/10%/20% 0 to 10%/20%/50% 0 to 20%/50%/100% With out	note 2											A	B	C	D	E	F	G	H	J	K	Y

Digit	Description	note	1	2	3	4	5	6	7	8	9	10	11	12	13	14	15	16	17	18	19	20	← Digit No. of code		
14	< Output > 0 to 1 V DC, non-isolated 4 to 20 mA DC, non-isolated		Z	S	V				Y	1							Y								
15	< Output type > Instantaneous value after O ₂ correction Average value after O ₂ correction CP calculation value With out	note 5,7 note 10 note 6															0	1	2	Y					
17	< Language > Japanese English																		1	2					
18	< Gas extractor > Non-fixed type (for intermittent measurement) Fixed type (for continuous measurement), flange 5K25A, L = 300 mm Fixed type (for continuous measurement), flange 5K25A, L = 400 mm Fixed type (for continuous measurement), flange 5K25A, L = 600 mm Fixed type (for continuous measurement), flange 5K25A, L = 800 mm With out																			1	2	3	4	5	Y
19	< Sample inlet tube > 5m×φ6/φ4, Teflon 10m×φ6/φ4, Teflon 20m×φ6/φ4, Teflon With out	note 8																				A	B	C	Y
20	< Adjustment > Standard adjustment Adjustment for heat treatment furnace Other	note 9																					A	B	Z

- Note 1) A parenthesized sample component stands for the 2nd optical system.
- Note 2) Specify code Y when only O₂ analyzer is needed.
- Note 3) Between "1", "2" and "3" of the 9th digit, the rated voltage and plug shape of the attached power cord are different.
 "1": For domestic use, rated voltage 125V AC (PSE), plug shape North American type
 "2": For European use, rated voltage 250V AC (ECC), plug shape European type
 "3": For North American use, rated voltage 125V AC (UL), plug shape North American type
- Note 4) For possible combinations of sample component and measuring range, refer to the following tables (on pages 8 and 9).
- Note 5) Specify this code when "1" or "2" is specified at the 6th digit.
- Note 6) When "Y" is specified at the 6th digit, "Y" should also be specified at the 15th digit.
- Note 7) The kind of output after O₂ correction will be added to all target components only when an analyzer for NO_x, SO₂ and CO is specified.
- Note 8) Sample inlet tube should be connected within 20 m.
- Note 9) Calibration curve varies with gas components contained in sample gas.
 "A ; standard adjustment" stands for adjustment in N₂ balance.
 "B ; adjustment for heat treatment furnace" is applied to CO analyzer and CO₂ analyzer.
 CO₂ analyzer: CO₂ range gas + 25% CO + 31% H₂/N₂
 CO analyzer: CO range gas + 5% CO₂ + 31% H₂/N₂
 When "Z; other" is specified, a gas composition table should be attached.
- Note 10) Can be manufactured only when " CO₂ analyzer" is selected for the 5th digit.

Tables of Sample Component and Measuring Range - Availability Check Tables -

Table 1: 1-Component Analyzer (CO₂, CO, CH₄)

Sample component Range		CO ₂ analyzer	CO analyzer	CH ₄ analyzer
		D	B	E
A	0 to 200/500/1000ppm	○	○	—
B	0 to 500/1000/2000ppm	○	○	—
C	0 to 1000/2000/5000ppm	○	○	○
D	0 to 2000/5000ppm/1%	○	○	○
E	0 to 5000ppm/1/2%	○	○	○
F	0 to 1/2/5%	○	○	○
G	0 to 2/5/10%	○	○	○
H	0 to 5/10/20%	○	○	○
J	0 to 10/20/50%	○	○	○
K	0 to 20/50/100%	○	○	○

○ : Product available

Table 2: 2-Component Analyzer (CO₂ analyzer + CO analyzer)

CO ₂ analyzer range		Range values are the same as those of CO ₂ analyzer.									
		A	B	C	D	E	F	G	H	J	K
A	0 to 200/500/1000ppm	○	○	—	—	—	—	—	—	—	—
B	0 to 500/1000/2000ppm	○	○	○	—	—	—	—	—	—	—
C	0 to 1000/2000/5000ppm	—	—	○	○	—	—	—	—	—	—
D	0 to 2000/5000ppm/1%	—	○	○	○	○	—	—	—	—	—
E	0 to 5000ppm/1/2%	—	○	○	○	○	○	○	○	—	—
F	0 to 1/2/5%	○	○	○	○	○	○	○	○	○	—
G	0 to 2/5/10%	○	○	○	○	○	○	○	○	○	○
H	0 to 5/10/20%	○	○	○	○	○	○	○	○	○	○
J	0 to 10/20/50%	—	○	○	○	○	○	○	○	○	○
K	0 to 20/50/100%	—	○	○	○	○	○	○	○	○	○

○ : Product available

Table 3: 2-Component Analyzer (CH₄ analyzer + CO analyzer)

CH ₄ analyzer range		Range values are the same as those of CH ₄ analyzer.									
		A	B	C	D	E	F	G	H	J	K
A	0 to 200/500/1000ppm	—	—	—	—	—	—	—	—	—	—
B	0 to 500/1000/2000ppm	—	—	—	—	—	—	—	—	—	—
C	0 to 1000/2000/5000ppm	—	—	—	—	—	—	—	—	—	—
D	0 to 2000/5000ppm/1%	—	—	—	—	—	—	—	—	—	—
E	0 to 5000ppm/1/2%	—	—	○	○	○	○	—	—	—	—
F	0 to 1/2/5%	—	—	○	○	○	○	○	○	—	—
G	0 to 2/5/10%	—	○	○	○	○	○	○	○	○	○
H	0 to 5/10/20%	—	○	○	○	○	○	○	○	○	○
J	0 to 10/20/50%	—	○	○	○	○	○	○	○	○	○
K	0 to 20/50/100%	—	○	○	○	○	○	○	○	○	○

○ : Product available

Table 4: 2-Component Analyzer (CO₂ analyzer + CH₄ analyzer)

CO ₂ analyzer range		Range values are the same as those of CO ₂ analyzer.									
		A	B	C	D	E	F	G	H	J	K
A	0~200/500/1000ppm	—	—	—	—	—	—	—	—	—	—
B	0~500/1000/2000ppm	—	—	—	—	—	—	—	—	—	—
C	0~1000/2000/5000ppm	—	—	—	—	○	—	—	—	—	—
D	0~2000/5000ppm/1%	—	—	—	○	○	○	—	—	—	—
E	0~5000ppm/1/2%	—	—	—	○	○	○	○	—	—	—
F	0~1/2/5%	—	—	—	○	○	○	○	○	—	—
G	0~2/5/10%	—	—	—	○	○	○	○	○	○	—
H	0~5/10/20%	—	—	—	○	○	○	○	○	○	○
J	0~10/20/50%	—	—	—	○	○	○	○	○	○	○
K	0~20/50/100%	—	—	—	○	○	○	○	○	○	○

○ : Product available

- 3-component analyzer (CH₄ analyzer + CO₂ analyzer + CO analyzer);

Possible range in combination of Table 1 (CH₄ analyzer) and Table 2 (CO₂ analyzer + CO analyzer)

One optical line (1 to 3-component gas sampling system diagram): Type ZSVS

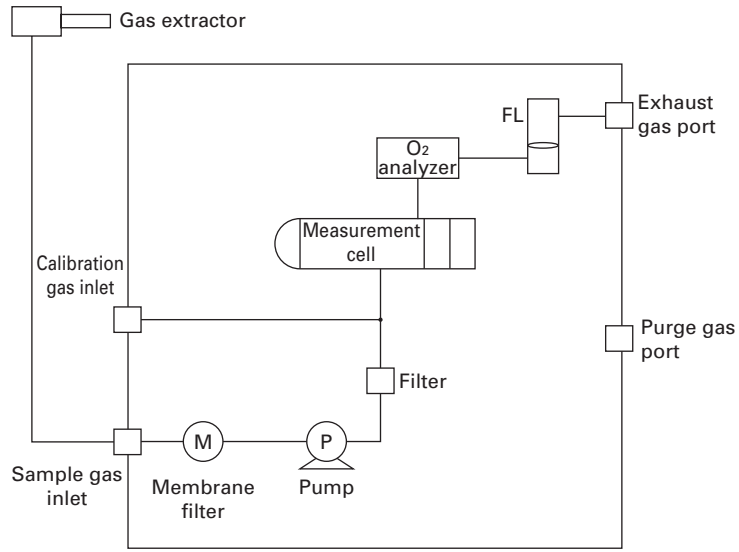

Two optical lines (3 to 4-component gas sampling system diagram): Type ZSVS

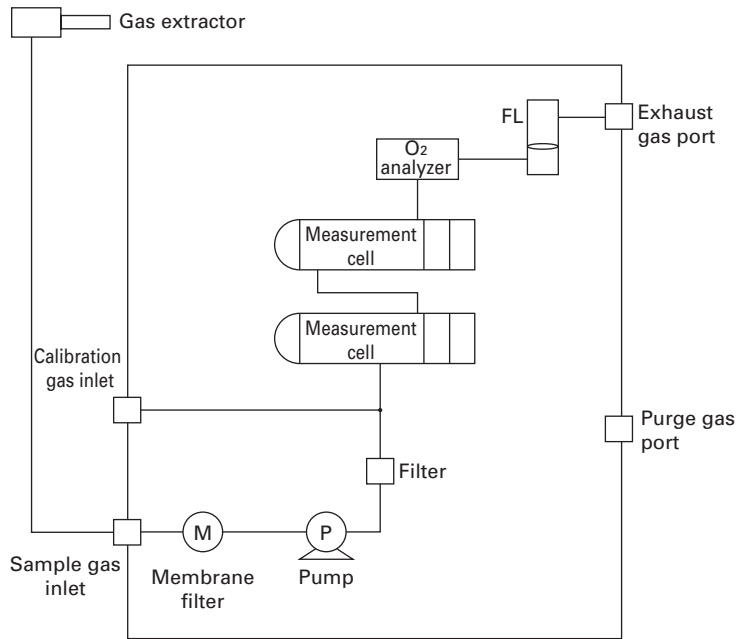

OUTLINE DIAGRAM (Unit : mm)

(1) Analyzing block

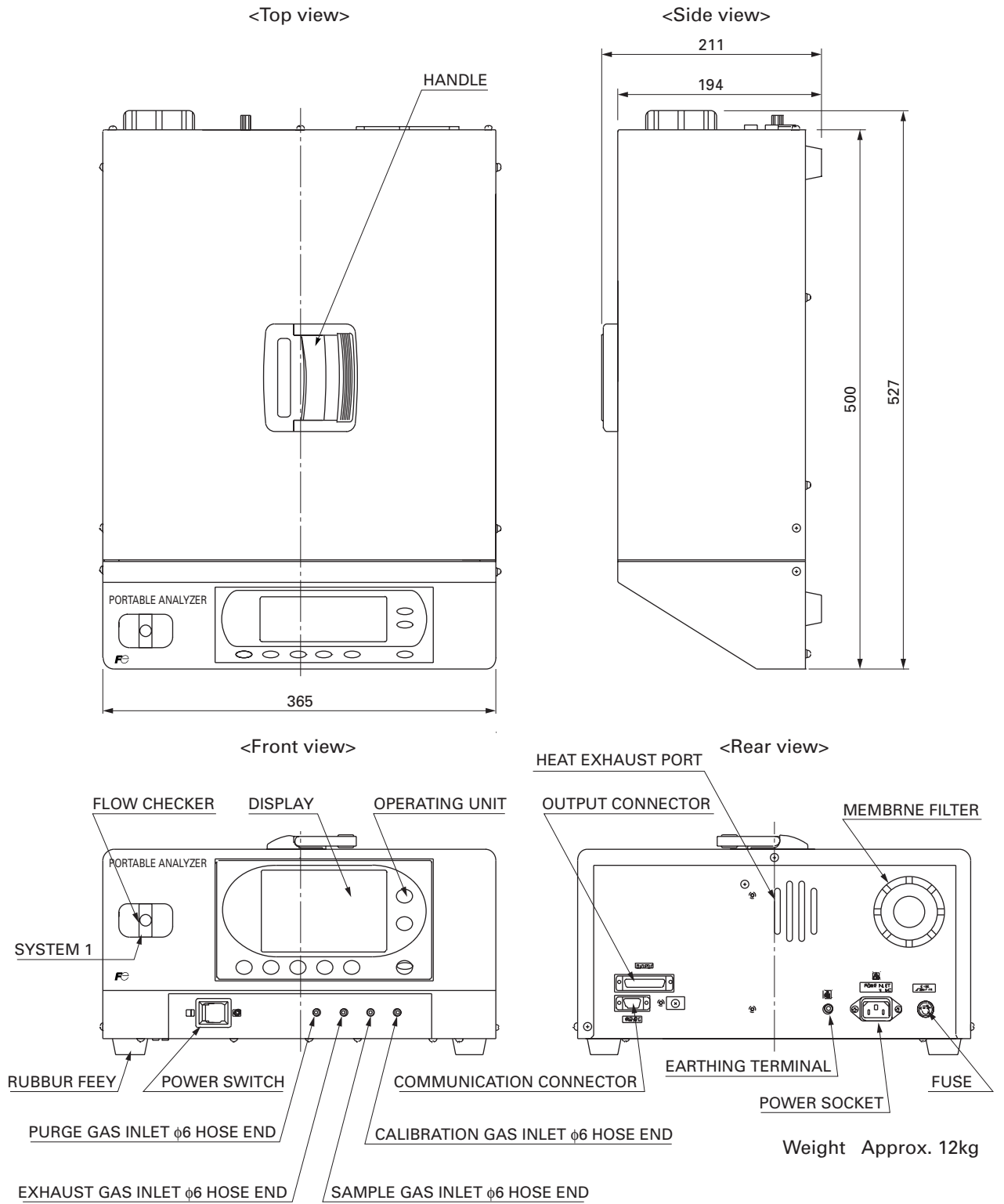

(2) External connection diagrams

Caution) Between male (P) and female (S) connectors, pin numbers are different.
Connect them properly with utmost care.

<Analog output>

On the analyzer side, a female connector (DB-25S-T-N made by Japan Aviation Electronics Industry) is attached.
For connection, the furnished cables (1 m)(DB-25P) should be used.

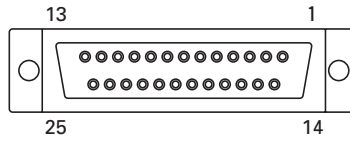

Color of furnished cable	Orange	Red	Brown	Black	White	Gray	Purple	Blue	Green	Yellow	Orange	Red	Brown
Pin name	CH7+	-CH6+	-CH5+	-CH4+	-CH3+	-CH2+	-CH1+						
Pin No.	13	12	11	10	9	8	7	6	5	4	3	2	1
Pin No.	25	24	23	22	21	20	19	18	17	16	15	14	
Pin name	NC										-CH8+	-CH7	
Color of furnished cable											Blue	Green	Yellow

<Communication output>

On the analyzer side, a male connector (DE-9P-T-N made by Japan Aviation Electronics Industry) is attached.
For connection, commercially available cross cables (DE-9S) should be used.

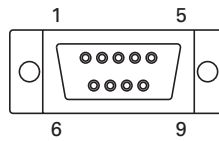

Pin name	NC	TXD	RXD	NC	GND
Pin No.	1	2	3	4	5
Pin No.	6	7	8	9	
Pin name	NC	NC	NC	NC	

OUTLINE DIAGRAM (Unit : mm)

(3) Power cord and signal cable

- Power cord for domestic and North American use (North American type), rated voltage 125V AC.
Note: The standards for domestic and North American use are different, but the shape is the same.

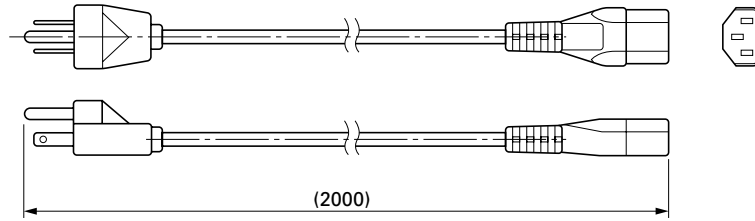

- Power cord for European use (European type), rated voltage 250 V AC

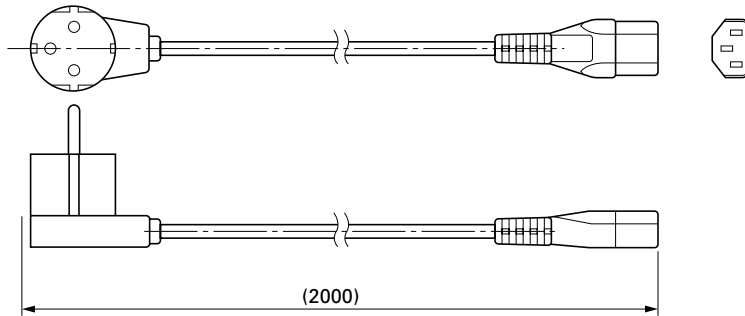

- Output cable

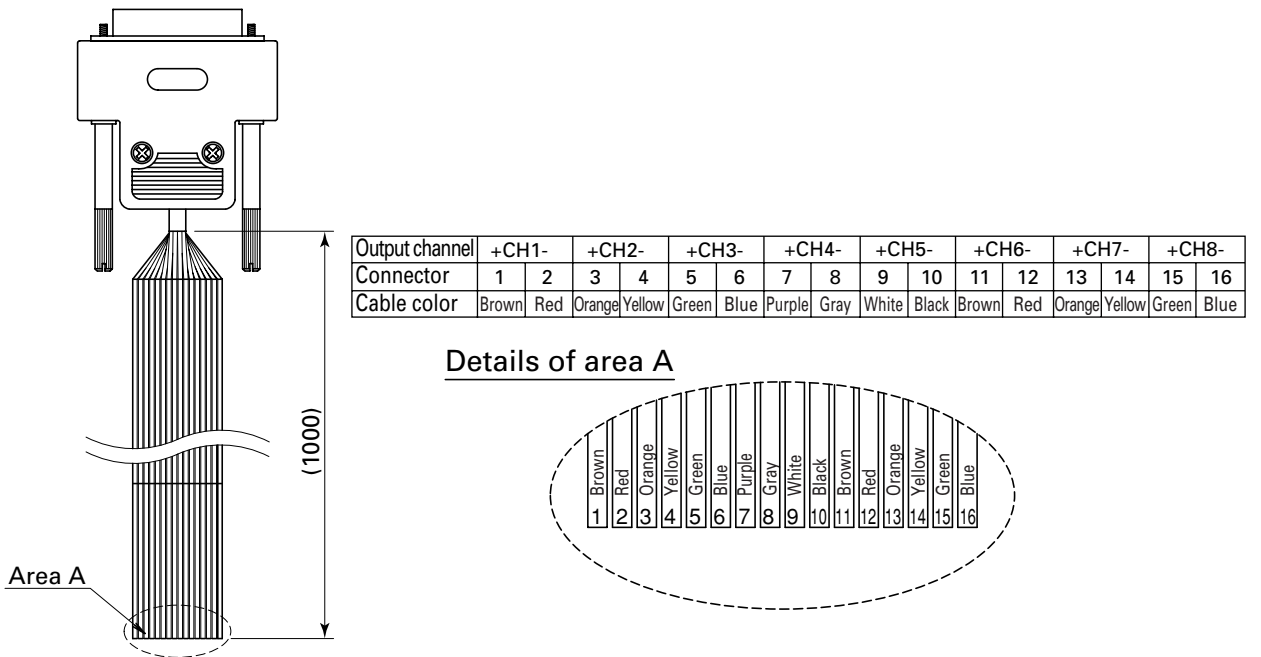

- Control input/output cable

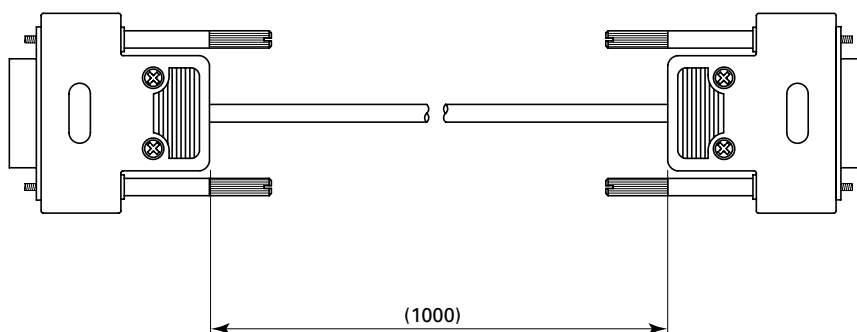

OUTLINE DIAGRAM (Unit : mm)

(4) Non-fixed type gas extractor

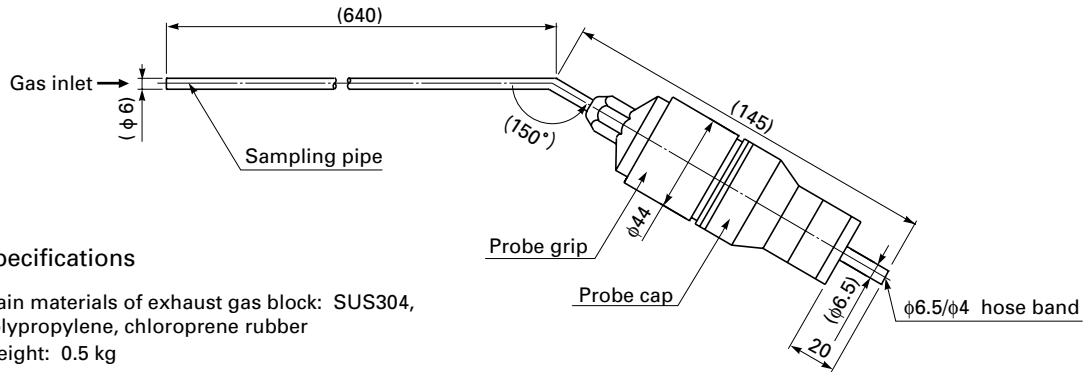

(5) Fixed type gas extractor

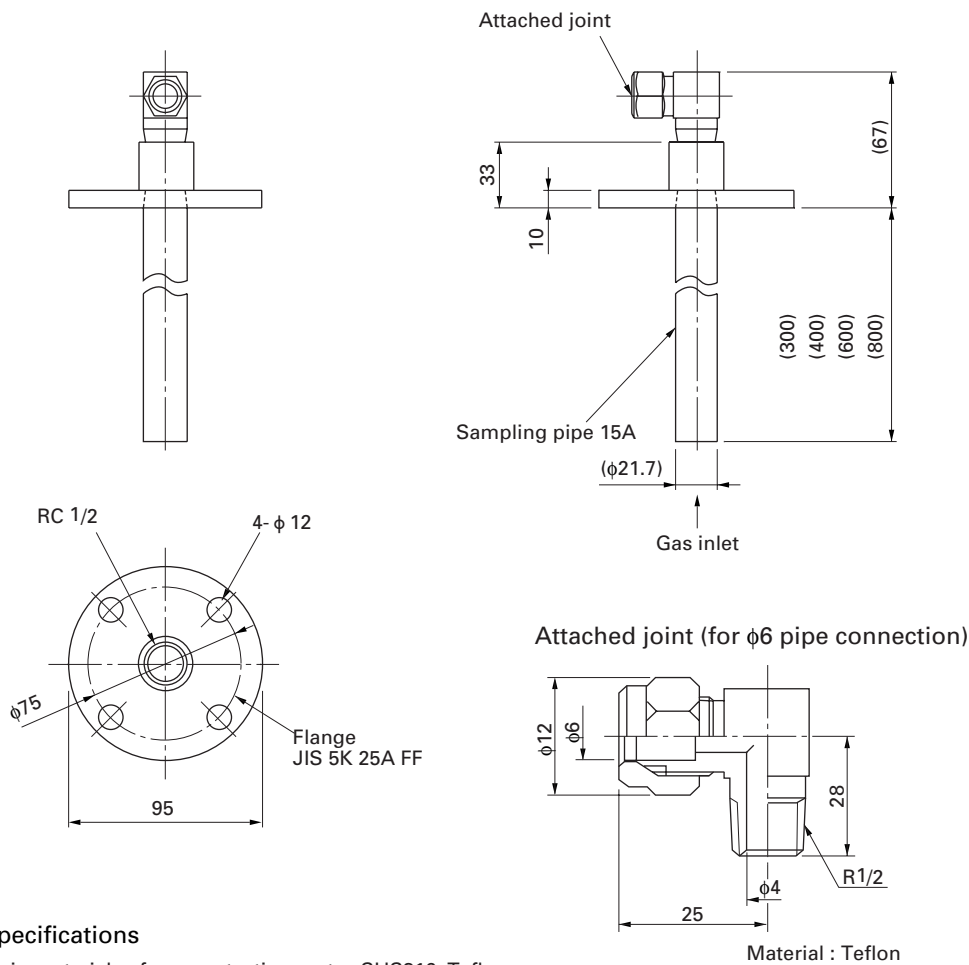

⚠ Caution on Safety

*Before using this product, be sure to read its instruction manual in advance.

Fuji Electric Systems Co., Ltd.

International Sales Div.5

Sales Group

Gate City Ohsaki, East Tower, 11-2, Osaki 1-chome,
Shinagawa-ku, Tokyo 141-0032, Japan

<http://www.fesys.co.jp/eng>

Phone: 81-3-5435-7280, 7281 Fax: 81-3-5435-7425

<http://www.fic-net.jp/eng>