

# INFRARED GAS ANALYZER FOR HEAT TREATMENT FURNACES

DATA SHEET

ZFG

## OVERVIEW

This gas analyzer (ZFG) is capable of measuring the concentrations of CO<sub>2</sub>, CO and CH<sub>4</sub> components in sample gas. Compact and lightweight design is intended, and a maximum of 2 components are simultaneously measurable.

A high-sensitivity mass flow sensor is used in the detector unit of infrared method. Due to use of single beam system for measurement, maintenance is easy and an excellent stability is ensured for a long period of time.

In addition, a microprocessor is built in and a large sized liquid crystal display is provided for easier operation, higher accuracy and more functions.

This analyzer is thus optimum for combustion control of various heat treatment furnaces.



## FEATURES

1. Compact and lightweight design is intended, and a maximum of 2 components are simultaneously measurable; 2 components selected from among CO<sub>2</sub>, CO and CH<sub>4</sub>.
2. A high stability mass flow sensor is used in the detector; The original optics (measurement block) minimizes drift particularly due to contamination of a measuring cell, so an excellent stability is ensured for a long period of time.
3. Subdued interference from other gas components; Interference from other gas components is insignificant, because the detector is a serial dual-layer type transmission detector.
4. Easy maintenance; Because of single-beam system, the measurement block is simple with no need for optical balance adjustment. Therefore, maintenance is easy.
5. Easy to operate; Operation can be carried out smoothly in an interactive way through a large-size liquid crystal display.
6. Abundant functions;
  - Zero/span can be accurately calibrated just by pressing the calibration keys.
  - An error will be detected by self-diagnostic function and indicated by error message.
  - Besides, a rich variety of functions are provided including CP calculation value output, remote range changeover input, range discrimination signal output and output signal holding.

## SPECIFICATIONS

### Standard Specifications

- **Measuring system:**  
Non-dispersive infrared absorption method with single light source and single beam (single beam method)
- **Measurable gas components and measuring range:**

	Min. measuring range	Max. measuring range
CO <sub>2</sub>	0 to 0.5%	0 to 100vol%
CO	0 to 0.5%	0 to 100vol%
CH <sub>4</sub>	0 to 1%	0 to 10%

  - Max. 2 components measurable
  - 2 ranges selectable
  - Measuring range ratio ≤ 1:5 max
- **Measured value indication:**  
Digital indication in 4 digits (LCD with back light, Automatic OFF function)
  - Instantaneous value of each component
  - Result display for CP calculation (optional)
 Display language: Japanese or English selectable
- **Analog output signals:**  
4 to 20mA DC, 0 to 1V DC, 0 to 10mV DC or 0 to 100mV DC  
Non-isolated output  
Analog output corresponds to measured value indication in 1:1.
- **Allowable load resistance:**  
4 to 20mA DC 550Ω or less  
0 to 1V DC, 0 to 100mV DC, or 0 to 10mV DC, 100kΩ or more

- **Contact output:**  
1a relay contact (250V AC/2A, resistive load)  
Instrument error (standard), range identification signal (optional)  
All relay contacts are isolated mutually from the internal circuit.
- **Contact input (optional):**  
No-voltage contact (ON/0V, OFF/5V DC, 5mA flowing at ON)  
Remote range changeover input, remote hold input  
Isolated from the internal circuit with photocoupler. Contact inputs are not isolated from one another.
- **Power supply:** Rated voltage 100 to 240V AC  
Operating voltage 85 to 264V AC  
Frequency; 50Hz/60Hz  
Power consumption; 50VA max.
- **Operation conditions:**  
Ambient temperature; -5 to 45°C  
Ambient humidity; 95% RH or less, no condensation
- **Storage conditions:**  
Ambient temperature; -20 to 60°C  
Ambient humidity; 95% RH or less, no condensation
- **Dimensions (H × W × D):**  
211 × 218 × 257 mm
- **Mounting dimensions:**  
Panel flash-mount type (vertical mounting on panel)
- **Weight:** About 5 kg
- **Finish color:** Off-white (Munsell 10Y7.5/0.5 or equivalent)
- **Enclosure:** Steel casing, for indoor use
- **Material of gas-contacting parts:**  
Gas inlet/outlet; SUS304,  
Sample cell; SUS304/neoprene rubber,  
Infrared-ray transmitting window; CaF<sub>2</sub>,  
Internal tubing; Toaron
- **Gas inlet/outlet:**  
Rc1/4 or NPT1/4 internal thread (as specified)
- **Purge gas flow rate:**  
1 L/min (to be purged as required)
- **External terminal:**  
Power terminal; M4 screw,  
Others; M3.5 screw

### Performance

- **Repeatability:** Within ±0.5% of full scale
- **Linearity:** Max.±1.0% of full scale (max.±2.0% of full scale when range ratio is 1:4 or 1:5)
- **Zero drift:** Within ±2% of full scale/week
- **Span drift:** Within ±2% of full scale/week
- **Response time (for 90% FS response):**  
Within 10 seconds
- **Interference from other gas components:**  
Within ±2%
- **Warm-up time:** Approx. 30 minutes

### Description of functions

- **Automatic OFF function (standard):**  
After OFF time is set, the LCD backlight automatically turns off when no key is operated. Press any key to turn on.
- **Output signal holding (standard):**  
By setting an output hold to ON, analog output signal is held in the value just before the manual calibration.
- **Instrument error contact output (standard):**  
When the main unit is abnormal, contact signal output is provided.
- **CP calculation (optional):**  
The carbon potential of carburizing furnace and conversion furnace are calculated using furnace temperature (fixed input value) and CO concentration value (fixed or measured value) while referring to CO<sub>2</sub> measured value.  
  
 Formula; 
$$CP = \frac{CPS \times (PCO)^2}{K1 \times PCO_2}$$
  - CPS ; Saturated carbon concentration (partial pressure)  
0.0028t-1.30 (800°C ≤ t < 850°C)  
0.0030t-1.47 (850°C ≤ t < 950°C)  
0.0034t-1.85 (950°C ≤ t < 1000°C)
  - t ; Furnace temperature (°C)
  - PCO ; CO concentration value (partial pressure)
  - PCO<sub>2</sub>; CO<sub>2</sub> concentration value (partial pressure)
  - K1 ; Constant K1=10 (9.06-15966/T)
  - T ; Rankine temperature (t×9/5+32+460)
- **Remote output holding (optional):**  
Output signal is held at the latest value or setting value by short-circuiting the remote output holding input terminals. Holding is maintained while the terminals are short-circuited.  
Indication values will not be held.
- **Remote range changeover (optional):**  
Range is selected by the contact input signal. Changeover is effective only when remote range setting is turned on. In this case, measuring range cannot be changed manually. When the contact input terminals for each component are short-circuited, the first range is selected, and it is changed over to the second range when the terminals are open.
- **Range identification signal (optional):**  
The present measuring range is identified by a contact signal. When the contact output terminals for each component are closed, the first range is selected, and it is changed over to the second range when the terminals are open.

### Standard Requirements for measuring gases

- **Flow rate:** 0.5L/min  $\pm$  0.2L/min or 1L/min  $\pm$  0.5L/min
- **Temperature:** 0 to 40°C
- **Pressure:** 5kPa or less (Gas outlet side should be open to the atmospheric air.)
- **Dust:** 0.3 $\mu$ m or less
- **Mist:** Unallowable
- **Moisture:** Below a level where saturation occurs at room temperature (condensation unallowable).
- **Corrosive component:** HCL 1ppm or less
- **Standard gas for calibration:**
  - Zero gas; Dry N<sub>2</sub> or dry air
  - Span gas; Each sample gas having concentration 90 to 100% of its measuring range (recommended). Unusable at concentrations beyond 100%.

### Installation condition

- Mount the instrument in a place that is not subject to direct sunlight, weathering nor radiation heat from high-temperature objects. If such a place cannot be found, a roof or cover should be prepared for protection.
- Avoid a place where receives heavy vibration.
- Select a clean environment.
- Discharge the exhaust gas into atmospheric air at a safe location.
- Avoid using the analyzer in an explosion-proof area.

### Standard gas sampling system

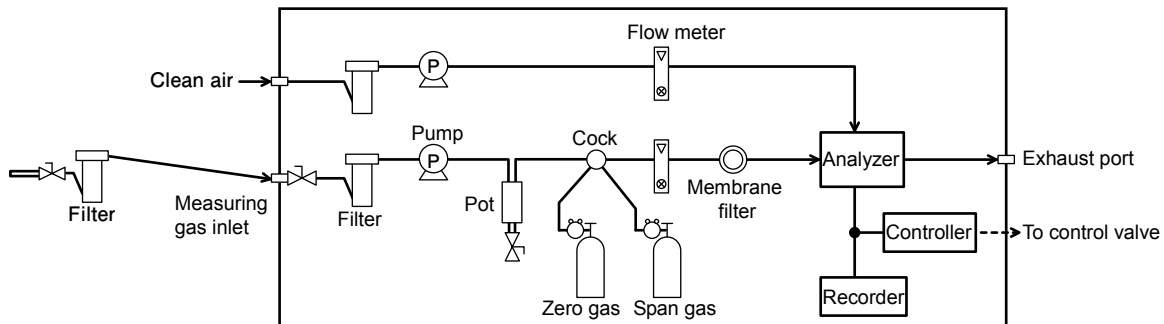

Note) This is the example of sampling which dose not contain water in the measuring gas.

### Principle diagram of NDIR type measurement (For CO, CO<sub>2</sub>, CH<sub>4</sub>)

Quantity of infrared ray that is absorbed by the measuring cell is detected with the mass flow sensor.

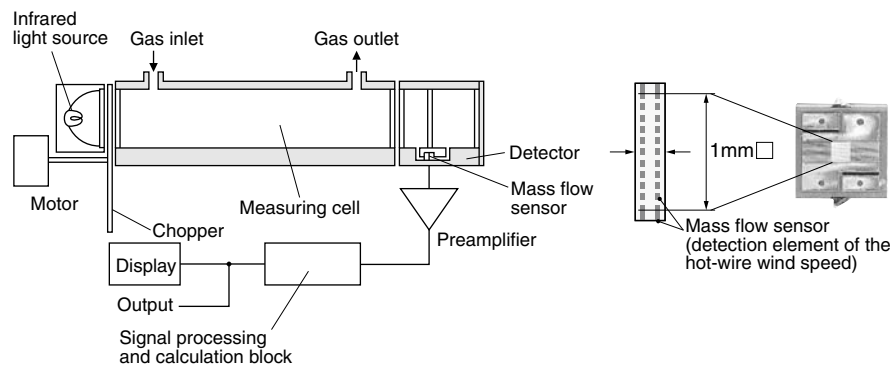



## Correspondence table of the possible measuring ranges

Table1: Single-component analyzer <CO<sub>2</sub>>

2nd range \ 1st range		Y	J	K	Q	L	M	N	V	W	P	X	R
		Without	0 to 1%	0 to 2%	0 to 3%	0 to 5%	0 to 10%	0 to 20%	0 to 25%	0 to 40%	0 to 50%	0 to 70%	0 to 100%
H	0 to 0.5%	○	○	○	○	-	-	-	-	-	-	-	-
J	0 to 1%	○	-	○	○	○	-	-	-	-	-	-	-
K	0 to 2%	○	-	-	○	○	○	-	-	-	-	-	-
Q	0 to 3%	○	-	-	-	○	○	-	-	-	-	-	-
L	0 to 5%	○	-	-	-	-	○	○	○	-	-	-	-
M	0 to 10%	○	-	-	-	-	-	○	○	○	○	-	-
N	0 to 20%	○	-	-	-	-	-	-	○	○	○	○	○
V	0 to 25%	○	-	-	-	-	-	-	-	○	○	○	○
W	0 to 40%	○	-	-	-	-	-	-	-	-	○	○	○
P	0 to 50%	○	-	-	-	-	-	-	-	-	-	○	○
X	0 to 70%	○	-	-	-	-	-	-	-	-	-	-	○
R	0 to 100%	○	-	-	-	-	-	-	-	-	-	-	-

Table2: Single-component analyzer <CO>

2nd range \ 1st range		Y	J	K	Q	L	M	N	V	W	P	X	R
		Without	0 to 1%	0 to 2%	0 to 3%	0 to 5%	0 to 10%	0 to 20%	0 to 25%	0 to 40%	0 to 50%	0 to 70%	0 to 100%
H	0 to 0.5%	○	○	○	○	-	-	-	-	-	-	-	-
J	0 to 1%	○	-	○	○	○	-	-	-	-	-	-	-
K	0 to 2%	○	-	-	○	○	○	-	-	-	-	-	-
Q	0 to 3%	○	-	-	-	○	○	-	-	-	-	-	-
L	0 to 5%	○	-	-	-	-	○	○	○	-	-	-	-
M	0 to 10%	○	-	-	-	-	-	○	○	○	○	-	-
N	0 to 20%	○	-	-	-	-	-	-	○	○	○	○	○
V	0 to 25%	○	-	-	-	-	-	-	-	○	○	○	○
W	0 to 40%	○	-	-	-	-	-	-	-	-	○	○	○
P	0 to 50%	○	-	-	-	-	-	-	-	-	-	○	○
X	0 to 70%	○	-	-	-	-	-	-	-	-	-	-	○
R	0 to 100%	○	-	-	-	-	-	-	-	-	-	-	-

Table3: Single-component analyzer <CH<sub>4</sub>>

2nd range \ 1st range		Y	K	Q	L	M	N	V	W	P	X	R
		Without	0 to 2%	0 to 3%	0 to 5%	0 to 10%	0 to 20%	0 to 25%	0 to 40%	0 to 50%	0 to 70%	0 to 100%
J	0 to 1%	○	○	○	○	-	-	-	-	-	-	-
K	0 to 2%	○	-	○	○	○	-	-	-	-	-	-
Q	0 to 3%	○	-	-	○	○	-	-	-	-	-	-
L	0 to 5%	○	-	-	-	○	○	○	-	-	-	-
M	0 to 10%	○	-	-	-	-	○	○	○	○	-	-
N	0 to 20%	○	-	-	-	-	-	○	○	○	○	○
V	0 to 25%	○	-	-	-	-	-	-	○	○	○	○
W	0 to 40%	○	-	-	-	-	-	-	-	○	○	○
P	0 to 50%	○	-	-	-	-	-	-	-	-	○	○
X	0 to 70%	○	-	-	-	-	-	-	-	-	-	○
R	0 to 100%	○	-	-	-	-	-	-	-	-	-	-

## Correspondence table of the possible measuring ranges

Table4: Two-component analyzer <CO<sub>2</sub>/CO>

1st component <CO <sub>2</sub> >		2nd component <CO>																1st range/2nd range			
1st range/ 2nd range	Code	0 to 0.5 /1%	0 to 1 /2%	0 to 1 /3%	0 to 2 /3%	0 to 2 /5%	0 to 3 /5%	0 to 5 /10%	0 to 10 /20%	0 to 10 /25%	0 to 20 /25%	0 to 20 /40%	0 to 20 /50%	0 to 25 /40%	0 to 25 /50%	0 to 40 /50%	0 to 40 /70%	0 to 50 /70%	0 to 50 /100%	0 to 70 /100%	0 to 100% /Without
		HJ	JK	JQ	KQ	KL	QL	LM	MN	MV	NV	NW	NP	VW	VP	WP	WX	PX	PR	XR	RY
0 to 0.5/1%	HJ	o	o	o	o	o	o	o	o	o	o	o	o	o	o	o	o	o	o	o	o
0 to 1/2%	JK	o	o	o	o	o	o	o	o	o	o	o	o	o	o	o	o	o	o	o	o
0 to 1/3%	JQ	o	o	o	o	o	o	o	o	o	o	o	o	o	o	o	o	o	o	o	o
0 to 2/3%	KQ	o	o	o	o	o	o	o	o	o	o	o	o	o	o	o	o	o	o	o	o
0 to 2/5%	KL	o	o	o	o	o	o	o	o	o	o	o	o	o	o	o	o	o	o	o	o
0 to 3/5%	QL	o	o	o	o	o	o	o	o	o	o	o	o	o	o	o	o	o	o	o	o
0 to 5/10%	LM	-	o	o	o	o	o	o	o	o	o	o	o	o	o	o	o	o	o	o	o
0 to 10/20%	MN	-	-	-	o	o	o	o	o	o	o	o	o	o	o	o	o	o	o	o	o
0 to 10/25%	MV	-	-	-	o	o	o	o	o	o	o	o	o	o	o	o	o	o	o	o	o
0 to 20/25%	NV	-	-	-	o	o	o	o	o	o	o	o	o	o	o	o	o	o	o	o	o
0 to 20/40%	NW	-	-	-	o	o	o	o	o	o	o	o	o	o	o	o	o	o	o	o	o
0 to 20/50%	NP	-	-	-	o	o	o	o	o	o	o	o	o	o	o	o	o	o	o	o	o
0 to 25/40%	VW	-	-	-	o	o	o	o	o	o	o	o	o	o	o	o	o	o	o	o	o
0 to 25/50%	VP	-	-	-	o	o	o	o	o	o	o	o	o	o	o	o	o	o	o	o	o
0 to 40/50%	WP	-	-	-	o	o	o	o	o	o	o	o	o	o	o	o	o	o	o	o	o
0 to 40/70%	WX	-	-	-	o	o	o	o	o	o	o	o	o	o	o	o	o	o	o	o	o
0 to 50/70%	PX	-	-	-	o	o	o	o	o	o	o	o	o	o	o	o	o	o	o	o	o
0 to 50/100%	PR	-	-	-	o	o	o	o	o	o	o	o	o	o	o	o	o	o	o	o	o
0 to 70/100%	XR	-	-	-	o	o	o	o	o	o	o	o	o	o	o	o	o	o	o	o	o
0 to 100%/Without	RY	-	-	-	o	o	o	o	o	o	o	o	o	o	o	o	o	o	o	o	o

Table5: Two-component analyzer <CO<sub>2</sub>/CH<sub>4</sub>>

1st component <CO <sub>2</sub> >		2nd component <CH <sub>4</sub> >														1st range/2nd range		
1st range/ 2nd range	Code	0 to 2 /3%	0 to 2 /5%	0 to 3 /5%	0 to 5 /10%	0 to 10 /20%	0 to 10 /25%	0 to 20 /25%	0 to 20 /40%	0 to 20 /50%	0 to 25 /40%	0 to 25 /50%	0 to 40 /50%	0 to 40 /70%	0 to 50 /70%	0 to 50 /100%	0 to 70 /100%	0 to 100% /Without
		KQ	KL	QL	LM	MN	MV	NV	NW	NP	VW	VP	WP	WX	PX	PR	XR	RY
0 to 1/2%	JK	o	o	o	o	o	o	o	o	o	o	o	o	o	o	o	o	o
0 to 1/3%	JQ	o	o	o	o	o	o	o	o	o	o	o	o	o	o	o	o	o
0 to 2/3%	KQ	o	o	o	o	o	o	o	o	o	o	o	o	o	o	o	o	o
0 to 2/5%	KL	o	o	o	o	o	o	o	o	o	o	o	o	o	o	o	o	o
0 to 3/5%	QL	o	o	o	o	o	o	o	o	o	o	o	o	o	o	o	o	o
0 to 5/10%	LM	-	-	-	o	o	o	o	o	o	o	o	o	o	o	o	o	o
0 to 10/20%	MN	-	-	-	o	o	o	o	o	o	o	o	o	o	o	o	o	o
0 to 10/25%	MV	-	-	-	o	o	o	o	o	o	o	o	o	o	o	o	o	o
0 to 20/25%	NV	-	-	-	o	o	o	o	o	o	o	o	o	o	o	o	o	o
0 to 20/40%	NW	-	-	-	o	o	o	o	o	o	o	o	o	o	o	o	o	o
0 to 20/50%	NP	-	-	-	o	o	o	o	o	o	o	o	o	o	o	o	o	o
0 to 25/40%	VW	-	-	-	o	o	o	o	o	o	o	o	o	o	o	o	o	o
0 to 25/50%	VP	-	-	-	o	o	o	o	o	o	o	o	o	o	o	o	o	o
0 to 40/50%	WP	-	-	-	o	o	o	o	o	o	o	o	o	o	o	o	o	o
0 to 40/70%	WX	-	-	-	o	o	o	o	o	o	o	o	o	o	o	o	o	o
0 to 50/70%	PX	-	-	-	o	o	o	o	o	o	o	o	o	o	o	o	o	o
0 to 50/100%	PR	-	-	-	o	o	o	o	o	o	o	o	o	o	o	o	o	o
0 to 70/100%	XR	-	-	-	o	o	o	o	o	o	o	o	o	o	o	o	o	o
0 to 100%/Without	RY	-	-	-	o	o	o	o	o	o	o	o	o	o	o	o	o	o

Table6: Two-component analyzer <CH<sub>4</sub>/CO>

1st component <CH <sub>4</sub> >		2nd component <CO>																1st range/2nd range		
1st range/ 2nd range	Code	0 to 1 /2%	0 to 1 /3%	0 to 2 /3%	0 to 2 /5%	0 to 3 /5%	0 to 5 /10%	0 to 10 /20%	0 to 10 /25%	0 to 20 /25%	0 to 20 /40%	0 to 20 /50%	0 to 25 /40%	0 to 25 /50%	0 to 40 /50%	0 to 40 /70%	0 to 50 /70%	0 to 50 /100%	0 to 70 /100%	0 to 100% /Without
		JK	JQ	KQ	KL	QL	LM	MN	MV	NV	NW	NP	VW	VP	WP	WX	PX	PR	XR	RY
0 to 1/2%	JK	o	o	o	o	o	o	o	o	o	o	o	o	o	o	o	o	o	o	o
0 to 1/3%	JQ	o	o	o	o	o	o	o	o	o	o	o	o	o	o	o	o	o	o	o
0 to 2/3%	KQ	o	o	o	o	o	o	o	o	o	o	o	o	o	o	o	o	o	o	o
0 to 2/5%	KL	o	o	o	o	o	o	o	o	o	o	o	o	o	o	o	o	o	o	o
0 to 3/5%	QL	o	o	o	o	o	o	o	o	o	o	o	o	o	o	o	o	o	o	o
0 to 5/10%	LM	o	o	o	o	o	o	o	o	o	o	o	o	o	o	o	o	o	o	o
0 to 10/20%	MN	o	o	o	o	o	o	o	o	o	o	o	o	o	o	o	o	o	o	o
0 to 10/25%	MV	o	o	o	o	o	o	o	o	o	o	o	o	o	o	o	o	o	o	o
0 to 20/25%	NV	o	o	o	o	o	o	o	o	o	o	o	o	o	o	o	o	o	o	o
0 to 20/40%	NW	o	o	o	o	o	o	o	o	o	o	o	o	o	o	o	o	o	o	o
0 to 20/50%	NP	o	o	o	o	o	o	o	o	o	o	o	o	o	o	o	o	o	o	o
0 to 25/40%	VW	o	o	o	o	o	o	o	o	o	o	o	o	o	o	o	o	o	o	o
0 to 25/50%	VP	o	o	o	o	o	o	o	o	o	o	o	o	o	o	o	o	o	o	o
0 to 40/50%	WP	-	-	o	o	o	o	o	o	o	o	o	o	o	o	o	o	o	o	o
0 to 40/70%	WX	-	-	o	o	o	o	o	o	o	o	o	o	o	o	o	o	o	o	o
0 to 50/70%	PX	-	-	o	o	o	o	o	o	o	o	o	o	o	o	o	o	o	o	o
0 to 50/100%	PR	-	-	o	o	o	o	o	o	o	o	o	o	o	o	o	o	o	o	o
0 to 70/100%	XR	-	-	o	o	o	o	o	o	o	o	o	o	o	o	o	o	o	o	o
0 to 100%/Without	RY	-	-	o	o	o	o	o	o	o	o	o	o	o	o	o	o	o	o	o

# OUTLINE DIAGRAM (Unit : mm)

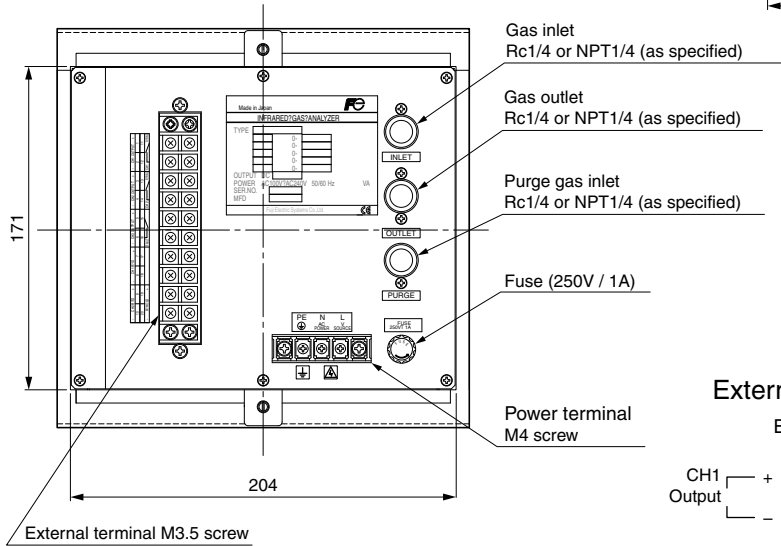
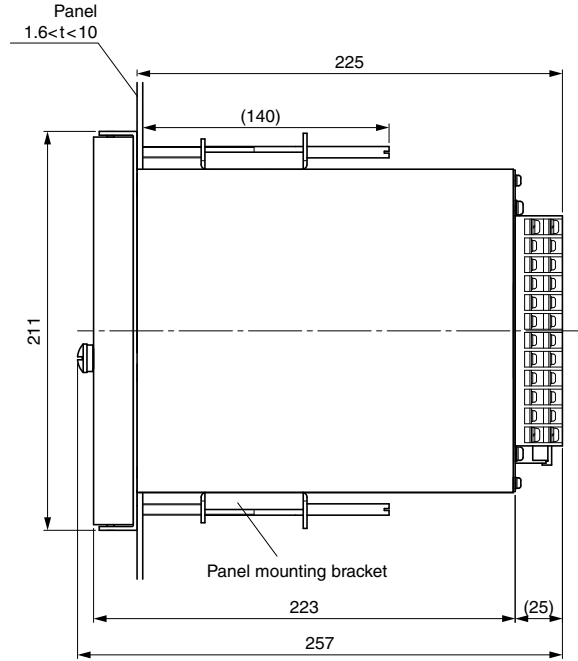
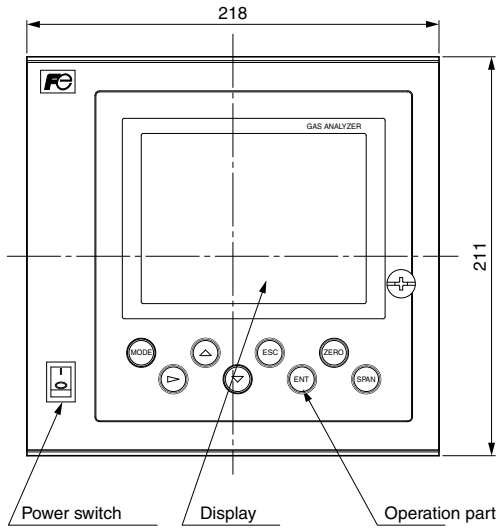

## Panel cut dimensions

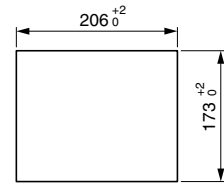

## External wiring diagram

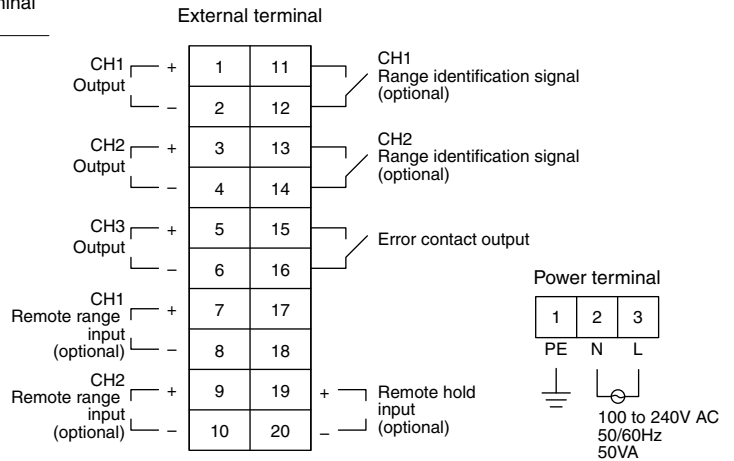

### Scope of delivery:

- Main unit
- Panel mounting bracket x1
- Power fuse x2 (250V AC 1A)
- Instruction manual; 1 copy

### Optional items:

- Gas sampling device
- Standard gas
- Receiving instrument, etc

### Ordering information

- Type
- Application and composition of sample gas (in case of nonstandard)

⚠ Caution on Safety

\*Before using this product, be sure to read its instruction manual in advance.

---

## **Fuji Electric Systems Co., Ltd.**

### **Head Office**

Gate City Ohsaki, East Tower, 11-2, Osaki 1-chome,  
Shinagawa-ku, Tokyo 141-0032, Japan

<http://www.fesys.co.jp/eng>

### **Instrumentation Div.**

#### **International Sales Dept.**

No.1, Fuji-machi, Hino-city, Tokyo, 191-8502 Japan  
Phone: 81-42-585-6201, 6202 Fax: 81-42-585-6187

<http://www.fic-net.jp/eng>

---

Information in this catalog is subject to change without notice.

Printed in Japan