

INFRARED GAS ANALYZER FOR STACK GAS

DATA SHEET

ZSU-4

This analyzer consists of an infrared gas analyzer, an O₂ sensor and a gas sampling device. It is used for simultaneous and continuous measurement of the NO_x, SO₂, CO, CO₂ and O₂ components in the flue gas of various boilers, garbage incinerators, etc.

For CO and O₂ measurement specifications, the function for coping with the Japanese regulation on dioxin emission is incorporated.

FEATURES

- Gas concentrations of 5 components is measurable simultaneously and continuously
NO_x, SO₂, CO and CO₂ gas concentration measurements are integrated by infrared method, to which a zirconia or magnetic type O₂ sensor is added for O₂ measurement. Therefore, the gas concentrations of 5 components are simultaneously and continuously measurable.
- The use of highly sensitive and reliable mass flow detector allows the range ratio of up to 1:25 with the standard 2 range.
- Maintenance can be performed from the front side, thus saving the installation space.
Unitized structure of the analyzing block and gas sampling module enables better maintenance.
- Provided with abundant functions including O₂ correction output, average value output, automatic calibration, CO peak count alarm, automatic range changeover, and alarms.
- N₂O and CH₄ can also be measured as an optional feature.
Having warming effect 300 times as high as that of CO₂, N₂O is the greenhouse gas most controversial now.

SPECIFICATIONS

1. Standard Specifications

•Measuring system :

NO_x, SO₂, CO and CO₂ ; Ndir type infrared

O₂ ; Zirconia type, magnetic type

•Measurable component and min./max. measurement range :

NO_x ; 0 to 50ppm/0 to 5000ppm

SO₂ ; 0 to 50ppm/0 to 5000ppm

CO ; 0 to 50ppm/0 to 5000ppm

CO₂ ; 0 to 10%/0 to 20%

O₂ ; 0 to 10%/0 to 25%

N₂O and CH₄ can be measured as an optional feature.

•Number of measurement ranges :

2 Maximum range ratio: 1:25 (Refer to Code Symbols.)

•Warm-up time : Within 4 hours after power-on



•Analog output signals :

Simultaneous output of signals of 4 to 20 mA DC each (non-isolated or isolated depending on customer's code selection)

- Five instantaneous value outputs (NO_x, SO₂, CO, CO₂ and O₂)
- Three instantaneous values (NO_x, SO₂, CO) after O₂ correction when provided with O₂ sensor
- Three average values (NO_x, SO₂, CO) after O₂ correction when provided with O₂ sensor
- Allowable load resistance : 550 Ω or less (750 Ω or less for isolated output)

•Contact output:

- (1) Each 1a contact (contact capacity 250 V AC, 2 A or 30 V DC, 3 A) for:
 - Range identification of each component (Close/1st range) , analyzing block error, calibration error, auto calibration status, maintenance status, and CO peak count alarm
- (2) Each 1c contact (contact capacity 250 V AC, 1 A or 30 V DC, 1 A) for:
 - Concentration alarm for each component's instantaneous value (H, L, HL settable), analyzing block power off

- **Contact input :** Non-voltage contact (1.5 sec or longer)
 - Auto calibration start, average value resetting
 - Non-voltage contact (Status holded)
 - Range changeover (1st range when contact closes), output hold, remote pump OFF (OFF when contact closes)
- **Indication :** LCD with back light for indicating:
 - Instantaneous values (NO_x , SO_2 , CO , CO_2 and O_2)
 - O_2 corrected instantaneous values (NO_x , SO_2 , CO) after O_2 correction when provided with O_2 sensor
 - O_2 corrected average values (NO_x , SO_2 , CO) after O_2 correction when provided with O_2 sensor
 - O_2 average value when provided with O_2 sensor
 - Peak count value (when provided with CO , O_2 analyzer)
 - Parameter assignment
- **Fluorescent lamp in cubicle :** Standard equipment
- **Recorder (option) :** Paperless recorder (Fuji Electric's type PHR) mounted
- **Gas extractor :** Electrical heating type (filter built in)
 - Wire mesh filter : 40 μm mesh of SUS 316 stainless steel
 - Flange : JIS 5K 65AFF
 - Mass: Approx. 9 kg (excluding gas sampling pipe)
 - Power supply voltage: 100 V AC, 50/60 Hz
 - Power consumption: Approx 100 VA
 - Sampling pipe: Refer to Code Symbols for materials and length of the pipe. SUS 316 (length 300, 400, 600, 800, 1000 mm), or titanium (length 600, 800, 1000 mm), or SiC (length 700, 900 mm)
 - * SUS 316 is used for 800°C or lower.
 - * Titanium is used for 1000°C or lower.
 - * SiC is used for 1300°C or lower.
- **Sample inlet tube :**
 - $\phi 10 / \phi 8$ Teflon tube or heating tube (max. 30 m)
 - *The heating tube needs to be specified in the following cases.
 - (1) Ambient temperature -5°C or lower
 - (2) SO_2 of 50 or 100 ppm
 - (3) Tube length 10 m or longer in SO_2 measurement
 (Power supply voltage: 100 V AC, 50/60 Hz, power consumption: 36 VA/m)
- **Rated operating conditions :**
 - Ambient temperature: -5 to 40°C (depending on customer's code selection)
 - Ambient humidity: 90% RH or less
 - Power supply voltage: 100, 110, 115, 200 or 230 V AC $\pm 15\%$ (Fluorescent lamp: $\pm 10\%$) (depending on customer's code selection)
 - Frequency: 50 or 60 Hz ± 0.5 Hz
- **Power consumption:** Max. 600 VA (excluding gas extractor and heating tube)
- **Storage condition:**
 - Ambient temperature; -20 to 60°C (Water within the drain pot should be drained before storage.)
 - Ambient humidity; 95%RH or lower (Required for a oil/coal boiler or when the first range of the SO_2 meter for gas dryer purging is 500 ppm or higher.) Dew point; -20°C DP or lower Pressure; 100 kPa to 400 kPa Dust and mist; None
- **Dry air :**
- **External dimensions (H x W x D) :**
 - Indoor type; 1710 x 800 x 615 mm
 - Outdoor type; 1780 x 815 x 700 mm
- **Mass :** Approx. 300 kg (excluding standard gas)
- **Cubicle finish color :** Munsell 5Y7/1 semi-gloss
- **Cubicle structure :** Indoor or outdoor installation, of self-standing type, single-swing front door, plate thickness 2.3 mm standard (both cubicle and door)
- **Other :** Six standard gas cylinders (3.4 L) accommodatable
Note: Fluctuation in the operation period of 4 hours from the end of warm-up time is within $\pm 2\%$ FS.
- **Measurement Law type approval No.:**
 - SAN991-1 (NO_x analyzer)
 - SAS992-1 (SO_2 analyzer)
 - SAC992-1 (CO analyzer)
 - SE981 (Zirconia O_2 sensor)
 - SF011 (Magnetic O_2 sensor)

2. Standard Functions

Function	Description
O ₂ Correction	<ul style="list-style-type: none"> Conversion of measured NO_x, SO₂ and CO gas concentrations into values at standard O₂ concentration <p>Calculating equation : $C = \frac{Cs(21-O_N)}{21-O_s}$</p> <p>C : Sample gas concentration after O₂ correction Cs : Measured concentration of sample gas Os : Measured O₂ concentration ON : Standard O₂ concentration (4% for petroleum fuel, 5% for gas fuel, 6% for coal fuel, 12% for garbage incinerator) Setting range: 0 to 19%</p> <ul style="list-style-type: none"> The result of conversion is indicated and output in a signal of 4 to 20 mA DC.
Auto Calibration	<ul style="list-style-type: none"> The gas analyzer is automatically calibrated. Auto calibration cycle settable range: 1 to 99 hours (1-hour step) or 1 to 40 days (1-day step) Auto calibration gas injection time settable range: 60 to 599 seconds (in 1-sec step) Auto/manual calibration error contact output: Provided when calibration quantity exceeds 50% of full scale. Contact output during auto calibration and maintenance: Provided during calibration gas flow and replacement. Also provided during maintenance. Auto calibration remote start contact input: Calibration starts at opening after short-circuit for 1.5 sec or longer. Standard gas consumption: Approx. 1 year with 3.4L cylinder in a calibration cycle of 7 days
Average Value after O ₂ Correction, O ₂ average value	<ul style="list-style-type: none"> NO_x, SO₂ and CO values are averaged after O₂ correction, and the result is indicated and output in 4 to 20 mA DC. Averaging time is settable by key operation at the front of analyzing block. Settable range: 1 to 59 minutes or 1 to 4 hours (factory-set at 1 hour)
Remote Output Hold	<ul style="list-style-type: none"> The output signal values are collectively held according to external contact input. Output is held during short-circuit.
Average Value Resetting Input	<ul style="list-style-type: none"> Output and indication of average value after O₂ conversion are reset according to external contact input. Output and indication are reset at short-circuit for 1.5 sec or longer.
Automatic range changeover	<ul style="list-style-type: none"> Automatically changed from low range to high range, and from high range to low range. Low → High: Changed at 90% point of the low range High → Low: Changed at 80% point of the high range
Remote range Changeover Input	<ul style="list-style-type: none"> Low or high range is selectable for each sample component via external contact input. High range is selected for open-circuit, and low range for short-circuit.
Range Identification Contact Output	<ul style="list-style-type: none"> Identification between low and high ranges is output through a contact. When the contact is closed, low range is selected.
Concentration Alarm Contact Output	<ul style="list-style-type: none"> Instantaneous value alarm is settable for each sample component. High, Low, High or Low is settable (by keys at the front of analyzing block). Contact output hysteresis is also settable. Contact is 1c type.
CO Instantaneous Value Peak Count Alarm Contact Output	<ul style="list-style-type: none"> Alarm is issued and indicated when CO instantaneous value has exceeded the set limit by the set number of times. Settable number of times: 1 to 99, alarm settable range: 10 to 1000 ppm (5 ppm step) The number of overshootings per hour is indicated.
Analyzing Block Error Contact Output	<ul style="list-style-type: none"> Contact output is provided when the analyzing block is abnormal.
Temperature Input Signal	<ul style="list-style-type: none"> K thermocouple input x 2 (for recorder available at option)

3. Performance

- **Repeatability :** $\pm 0.5\%$ of full scale
- **Zero drift :** $\pm 1.0\%$ of full scale or lower/week
($\pm 2.0\%$ of full scale/week when the range is less than 200 ppm)
Max. $\pm 2.0\%$ of full scale/month on O₂ sensor
- **Span drift :** Max. $\pm 2.0\%$ of full scale/week
Max. $\pm 2.0\%$ of full scale/month on O₂ sensor
- **Linearity :** Max. $\pm 1.0\%$ of full scale
- **Response time :** For 90% indication (after extracting sample gas through the inlet)
NO_x : 120 sec or shorter
SO₂ : 240 sec or shorter
CO : 120 sec or shorter
CO₂ : 120 sec or shorter
O₂ : 120 sec or shorter
- **Sample gas flow rate :**
Approx. 2L/min

4. Standard Requirements for Sample Gas

- **Temperature :** Standard : 60 to 800°C
Non standard : 1000°C (titanium probe)
1300°C (SiC probe)
- **Dust :** 100 mg/Nm³ or less
- **Pressure :** -3k to +3kPa
- **Components :**

SO ₂	500 ppm or less
NO _x	1000 ppm or less
CO ₂	0 to 15%
CO	2000 ppm or less
O ₂	1 to 21%
HCL	100 ppm or less
The remaining	N ₂ , H ₂ O

5. Installation Requirements

- (1) Selection of a place which does not receive direct sunlight or radiation from hot substances
If such a place cannot be found, a roof or cover should be prepared for protection.
- (2) Avoidance of a place under heavy vibration
- (3) Selection of a place where atmospheric air is clean

SCOPE OF DELIVERY

- Gas analyzer system
- Specified external drain separator/drain pot
- Specified gas extractor/probe set
- Specified gas inlet tube set
- Standard accessories

ITEMS TO BE PREPARED SEPARATELY

1. Standard gas and pressure regulator
(Refer to ZSY of CODE SYMBOLS)
2. Recorder (when necessary) type PHR
3. Individual inspection of measurement method
4. 1-year spare (Refer to ZBN of CODE SYMBOLS)
5. Waterproof gland for outdoor wiring port (A25A),
Order No.: 8641625
6. Anchor bolt

5-Component Gas Sampling System Diagram 1 (Standard type with SO₂ first range of less than 500ppm)

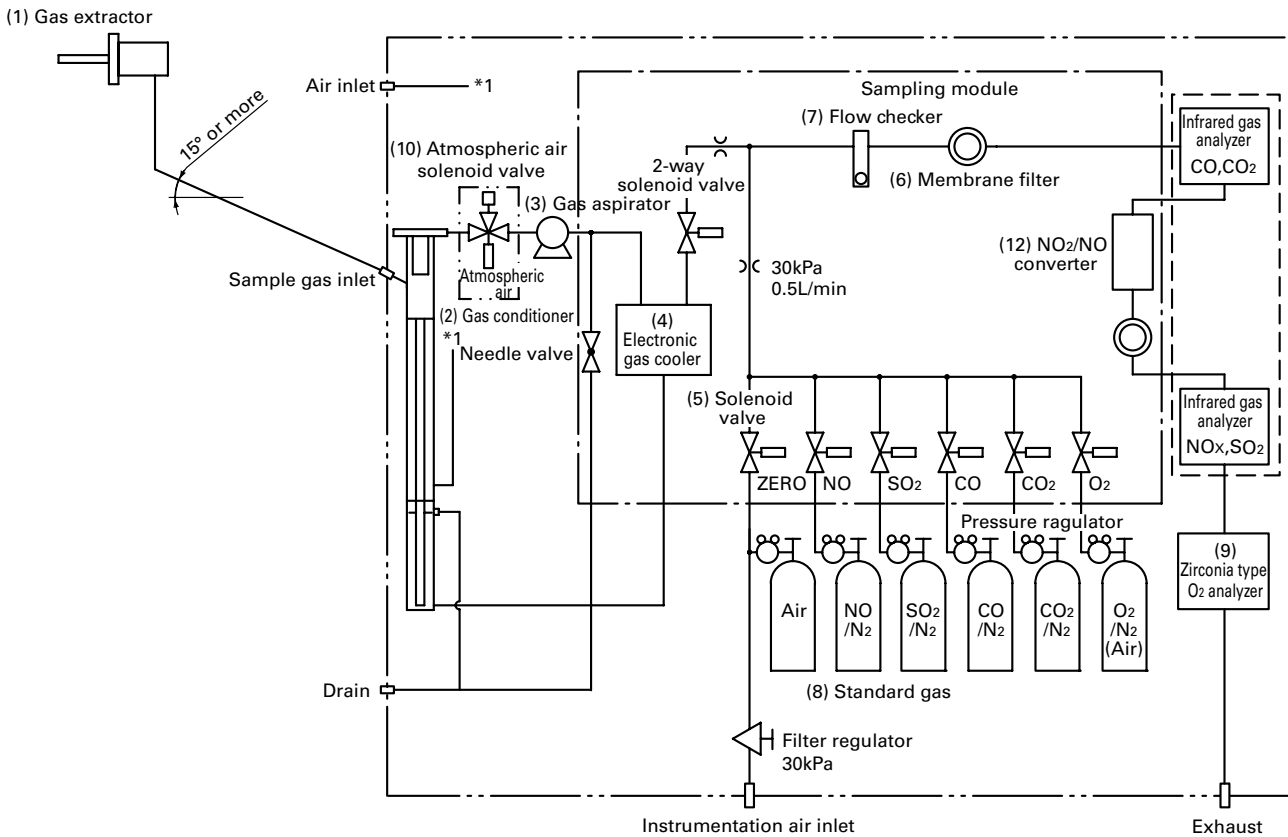

Functions of Individual Components

- (1) **Gas extractor:** Gas extraction, with heating type stainless steel filter having a standard diameter of 40 μ m
- (2) **Gas conditioner:** Removes drain, mist and dust, and monitors the gas pressure.
- (3) **Gas aspirator:** Aspirates sample gas (Flow rate of sample gas: Approx. 2L/min)
- (4) **Electronic gas cooler:** Dries the moisture in the sample gas.
- (5) **Solenoid valve:** Used for introducing calibration gas.
- (6) **Membrane filter:** PTFE filter, glassfiber filter used to eliminate fine dust particles and permit monitoring of dust adhering condition on the gas analyzer.
- (7) **Flow checker:** Monitors the sample gas flow rate (it can be controlled by the separate needle valve.)
- (8) **Standard gas:** Reference gas used for calibrating zero and span of the analyzer. Up to 6 gases (Zero gas air, span gas NO_x, SO₂, CO, CO₂ and O₂) can be used.
- (9) **O₂ sensor:** Used for measuring the oxygen concentration (0 to 25%) in sample gas.
- (10) **Atmospheric air solenoid valve:** Can be built in for using the atmospheric air instead of standard air.
- (11) **Switching box:** 7 power ON-OFF switches of the following equipments are built in.
- Gas extractor
 - Gas aspirator
 - Fluorescent lamp and service outlet (Max. 2A)
 - Sampling module
 - O₂ sensor
 - Heater for the gas conditioner
 - Ventilator
- (12) **Converter:** Added to NO_x analyzer. A special catalyst material for efficient conversion of NO₂ gas to NO is used.
- (13) **Pressure control valve:** Pressure adjustor to keep the sample gas pressure at a fixed level.
- (14) **Gas dryer:** Semi-permeable membrane type dehumidifier to dry the moisture in the sample gas to dew point -15°C or less.
- (15) **Mist catcher:** Removes sulfate mist in the sample gas. Replaced every 4 months when SO₃ concentration value is 30ppm. Added when SO₂ value is more than 0 to 500ppm or when oil/coal boiler is used.

5-Component Gas Sampling System Diagram 2

(Gas boiler or sludge incineration with SO₂ first range of less than 500ppm)

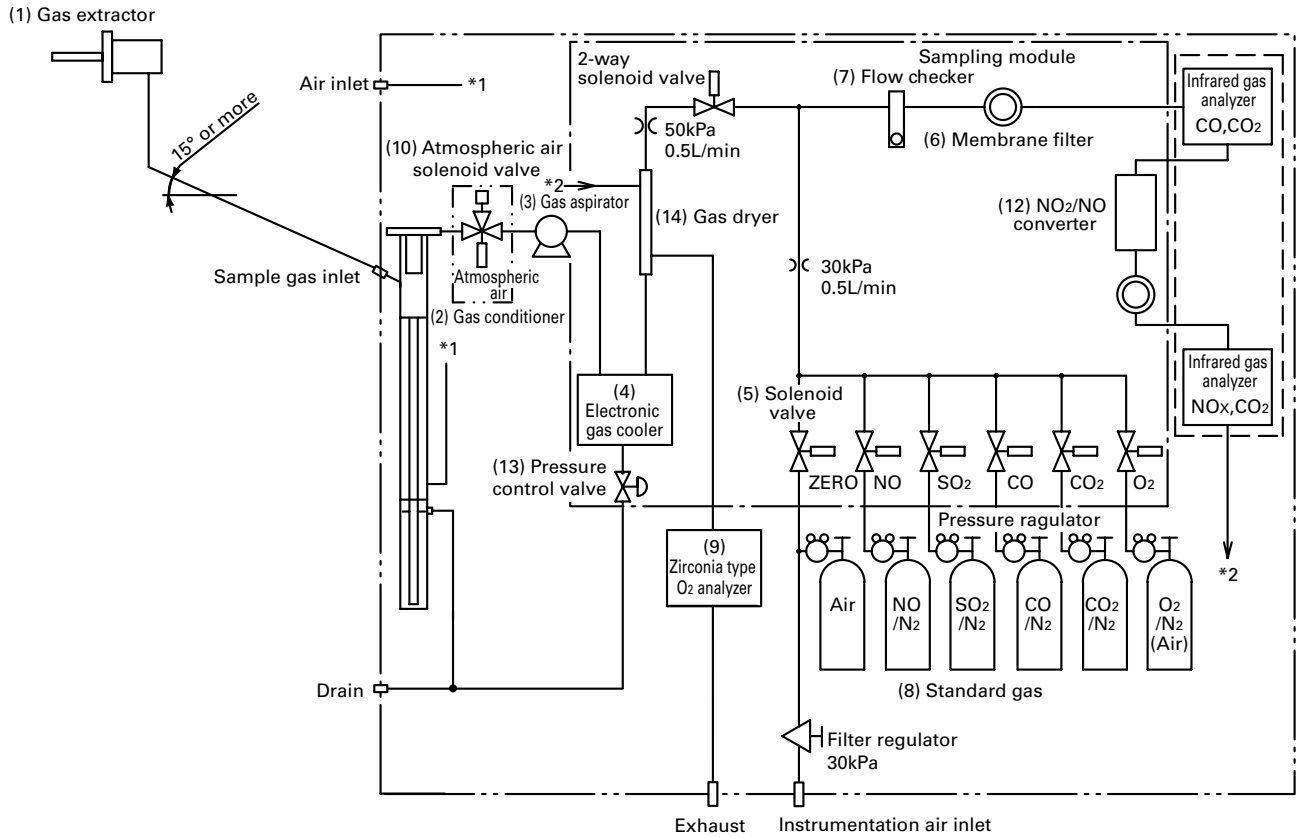

5-Component Gas Sampling System Diagram 3 (SO₂ first range of 500ppm or higher or oil/coal boiler)

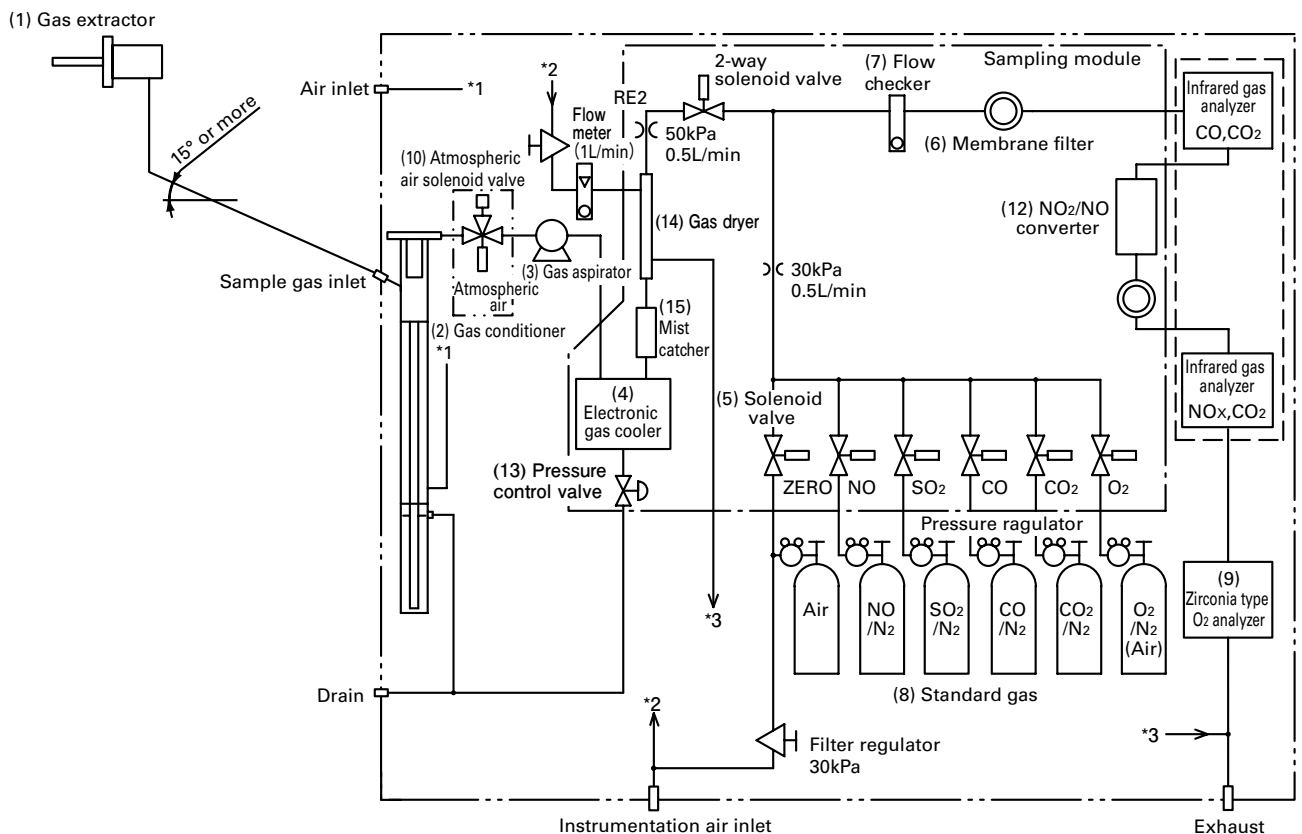

External Terminal Connection Diagram

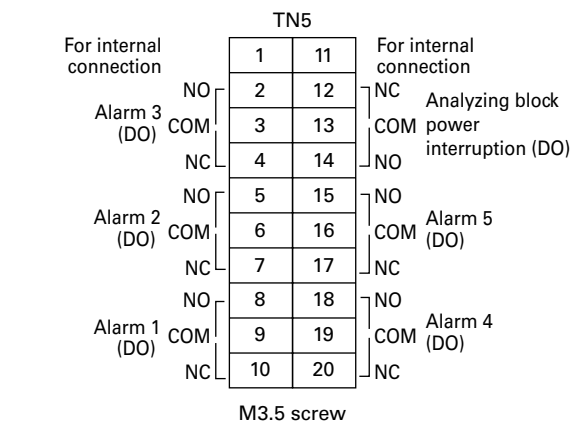
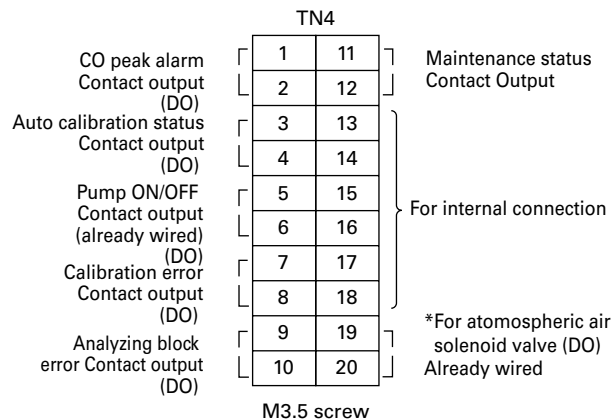
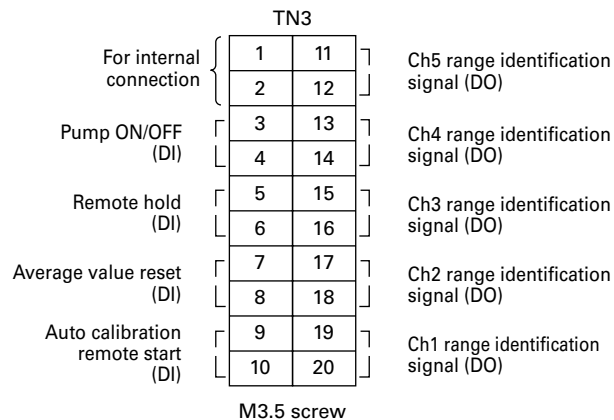
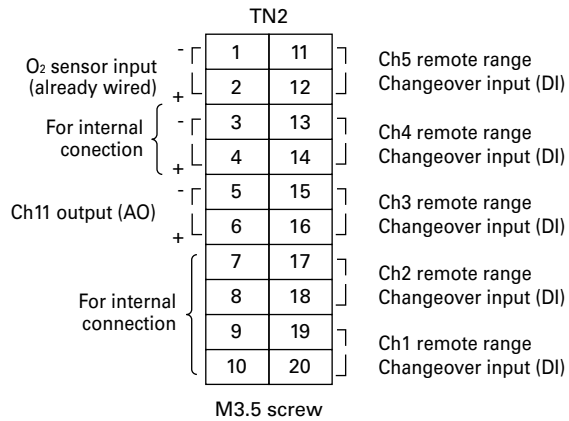
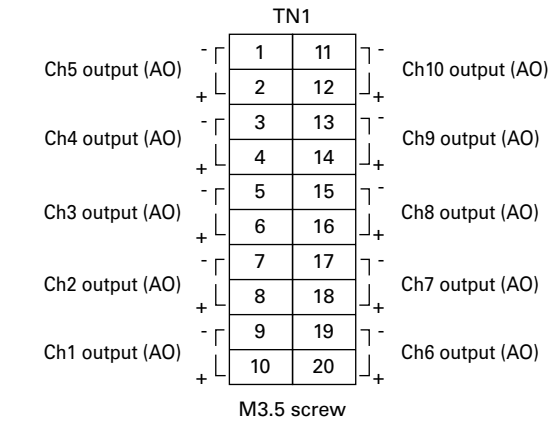
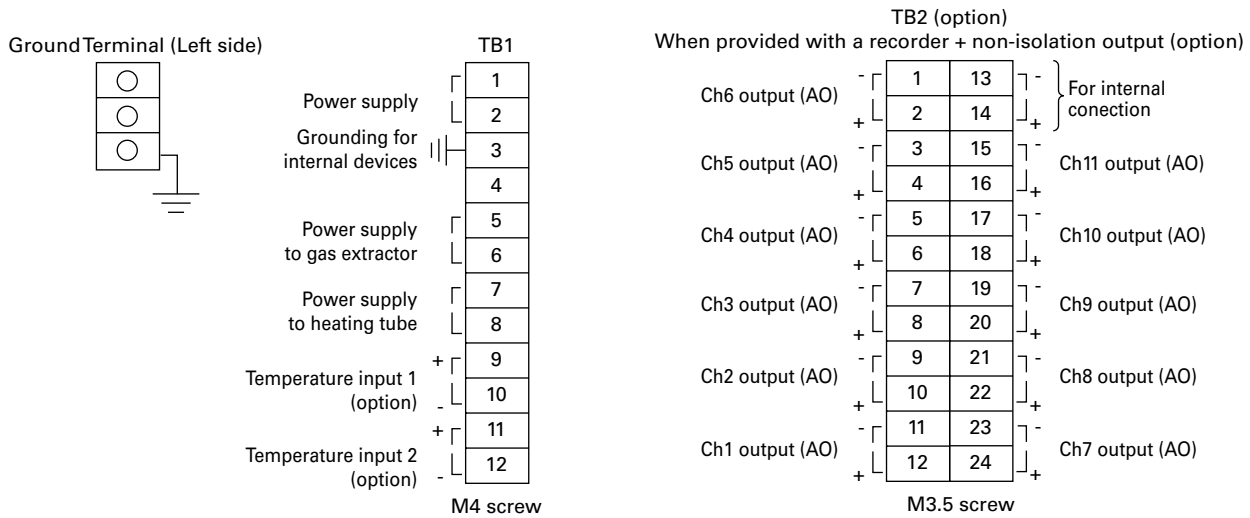

External terminal block diagram (Upper side of main unit)

TB1	TB2	TN1	TN2	TN3	TN4	TN5
1	1	13	1	11	1	11
2	2	14	2	12	2	12
3	3	15	3	13	3	13
4	4	16	4	14	4	14
5	5	17	5	15	5	15
6	6	18	6	16	6	16
7	7	19	7	17	7	17
8	8	20	8	18	8	18
9	9	21	9	19	9	19
10	10	22	10	20	10	20
11	11	23				
12	12	24				

Note) NO; normal open contact, NC; normal close contact

Contents of Measured Channel (CH)

The following table gives the contents of each output signal according to code symbols.

Code symbol		Contents
4th digit	5th digit	
P	0	Ch1: NO _x
A	0	Ch1: SO ₂
B	0	Ch1: CO
F	0	Ch1: NO _x , Ch2: SO ₂
H	0	Ch1: NO _x , Ch2: CO
L	0	Ch1: NO _x , Ch2: SO ₂ , Ch3: CO
M	0	Ch1: NO _x , Ch2: SO ₂ , Ch3: CO ₂ , Ch4: CO
P	4 to G	Ch1: NO _x , Ch2: O ₂ , Ch3: Corrected NO _x , Ch4: Corrected NO _x average
A	4 to G	Ch1: SO ₂ , Ch2: O ₂ , Ch3: Corrected SO ₂ , Ch4: Corrected SO ₂ average
B	4 to G	Ch1: CO, Ch2: O ₂ , Ch3: Corrected CO, Ch4: Corrected CO average
F	4 to G	Ch1: NO _x , Ch2: SO ₂ , Ch3: O ₂ , Ch4: Corrected NO _x , Ch5: Corrected SO ₂ , Ch6: Corrected NO _x average, Ch7: Corrected SO ₂ average
H	4 to G	Ch1: NO _x , Ch2: CO, Ch3: O ₂ , Ch4: Corrected NO _x , Ch5: Corrected CO, Ch6: Corrected NO _x average, Ch7: Corrected CO average
L	4 to G	Ch1: NO _x , Ch2: SO ₂ , Ch3: CO, Ch4: O ₂ , Ch5: Corrected NO _x , Ch6: Corrected SO ₂ , Ch7: Corrected CO, Ch8: Corrected NO _x average, Ch9: Corrected SO ₂ average, Ch10: Corrected CO average
M	4 to G	Ch1: NO _x , Ch2: SO ₂ , Ch3: CO ₂ , Ch4: CO, Ch5: O ₂ , Ch6: Corrected NO _x , Ch7: Corrected SO ₂ , Ch8: Corrected CO, Ch9: Corrected NO _x average, Ch10: Corrected SO ₂ average, Ch11: Corrected CO average

Standard Accessories

No.	Name	Quantity	Remarks	
1	Filter paper for membrane filter/as spare (Teflon)	4 pair	When SO ₂ meter is provided When SO ₂ meter is not provided	
	Filter paper for membrane filter (pack of 25)/as spare (glass fiber)	1 box		
2	Fuse (2A)/as spare	1 fuses	} When gas extractor is equipped When heating tube is equipped	
3	Fuse (3.2A)/as spare	1 fuses		
4	Standard gas joint R1/4 - φ6mm	1 set		
5	Hose band for fixing standard gas cylinder	1 set		
6	Toaron tube for standard gas connection, 1 m and φ9 / φ5mm	1 tube		
7	Polyethylene tube for standard gas connection, 6 m and φ6 / φ4mm	1 tube		
8	Anchor bolt for cubicle installation, (Option) M12 × 160 × 50	4		
9	Water bottle for injection	1		
10	Gas sampling pipe flange packing	1		
11	Gas extractor fastening bolt and nut (M12×60mm)	1 set		
12	Heating tube support	1 set		
13	Instruction manual (INZ-TN4ZSU-E)	1 copy		
14	Cell assembling tool	1		For CO ₂ measurement

Spare Parts for 1-Year Measurement

- 1 pairs of or 4 pack of filter paper for membrane filter (Note 1)
 - Membrane filter O-ring (G65) ×2
 - Membrane filter rubber-ring ×2
 - Filter element for conditioner filter ×2
 - O-ring (G65) for conditioner filter ×2
 - Diaphragm for gas aspirator ×1
 - Valve for gas aspirator ×1
 - Fuse (2A) ×4
 - Fuse (3.2A) ×3
 - Capillary for 50kPa/0.5L ×1
-When SO₂ first range is from 0 to 500 ppm or higher
 Not provided for gas boiler, sludge incineration, and oil/coal boiler
- O-ring for gas extractor (G50) ×1
 - Packing for gas extractor wire mesh filter ×1
 - Wire mesh filter packing for gas extraction ×1
 - O-ring (G45) for gas extraction ×1
 - NO_x/NO converter catalyst ×1
 - Glass wool for NO₂/NO converter
 - Fitting for NO₂/NO converter ×2
 - Mist catcher ×3
-SO₂ first range of 500 ppm or higher or oil/coal boiler

} Added when gas extractor is equipped

} Added when NO_x analyzer is equipped

(Note 1) 1 pairs for SO₂ analyzer, on 1 pack (25sheets) for other

Code Symbols for Spare Parts for 1-Year Measurement

1	2	3	4	5	6	7	8	Description
Z	B	N	4	S			2	(Application)
					U			----- Refuse incinerator, Gas boiler
					1			----- Oil/coal boiler
								(Gas extractor) (NO _x analyzer) (SO ₂ analyzer)
					0			----- Without Without Without
					1			----- With Without Without
					2			----- Without With Without
					3			----- With With Without
					A			----- Without Without With (Less than 500 ppm)
					B			----- With Without With (Less than 500 ppm)
					C			----- Without With With (Less than 500 ppm)
					D			----- With With With (Less than 500 ppm)
					E			----- Without Without With (500 ppm or higher)
					F			----- With Without With (500 ppm or higher)
					G			----- Without With With (500 ppm or higher)
					H			----- With With With (500 ppm or higher)

STANDARD GAS CODE SYMBOLS

1	2	3	4	5	6	7	8	9	10	11	Description
Z	S	Y					2				NO_x measurement first range <4th digit>,ppm Without 50 100 200 250 500 1000 2000 5000
			0								
			A								
			1								
			2								
			3								
			4								
			7								
											SO₂ measurement first range <5th digit>,ppm Without 50 100 200 250 500 1000 2000 5000
			0								
			A								
			1								
			2								
			3								
			4								
			7								
											CO measurement first range <6th digit>,ppm Without 50 100 200 250 500 1000 2000 5000
			0								
			A								
			1								
			2								
			3								
			4								
			7								
											CO₂ measurement first range <7th digit>,ppm Without 5 10 20
			Y								
			A								
			B								
											O₂ span gas <9th digit> Without 1.8 to 2% O ₂ / N ₂ 10% O ₂ / N ₂ AIR
			0								
			1							Note)	
			3								
											Zero gas <10th digit> Without Air cylinder (without certificate) Air cylinder (with certificate Japanese official organization) N ₂ cylinder (without certificate) N ₂ cylinder (with certificate)
			Y								
			A								
			B								
											Official certificate <11th digit> Without NO _x SO ₂ CO NO _x , SO ₂ NO _x , CO NO _x , SO ₂ , CO NO _x , O ₂ SO ₂ , O ₂ CO, O ₂ NO _x , SO ₂ , O ₂ NO _x , CO, O ₂ NO _x , SO ₂ , CO, O ₂
			Y								
			A								
			B								
			C								
			D								
			E								
			F								
			G								
			H								
			J								
			K								
			L								
			M								

Note: Select "1" for the 9th digit and "A" or "B" for the 10th digit for zirconia type O₂ sensor.
 For the magnetic type O₂ sensor, select "2" or "3" for the 9th digit according to the selection of the first range, and select "C" or "D" for the 10th digit.

Scope of Delivery: standard gas (3.4L) with pressure regulator

OUTLINE DIAGRAM (Unit: mm)

<Gas extractor>

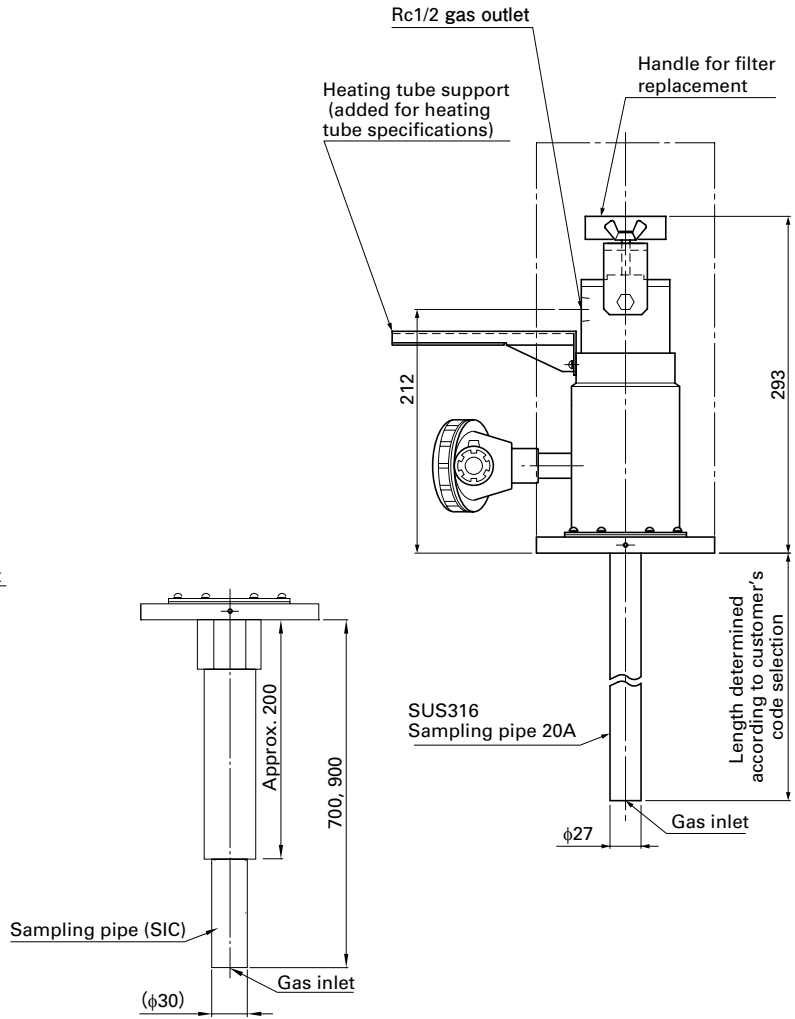
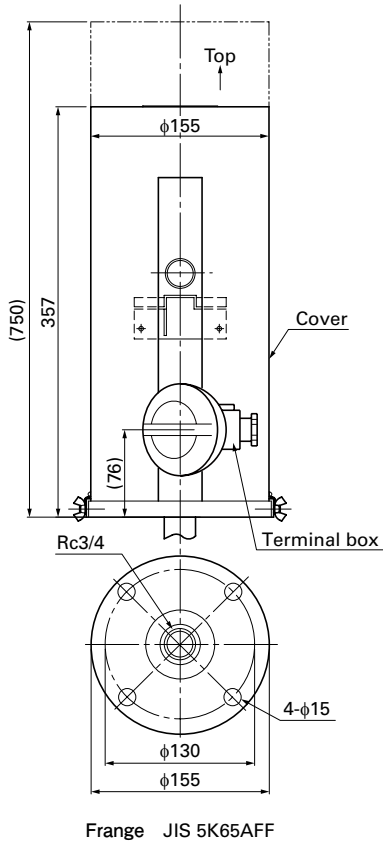

<Drain separator>

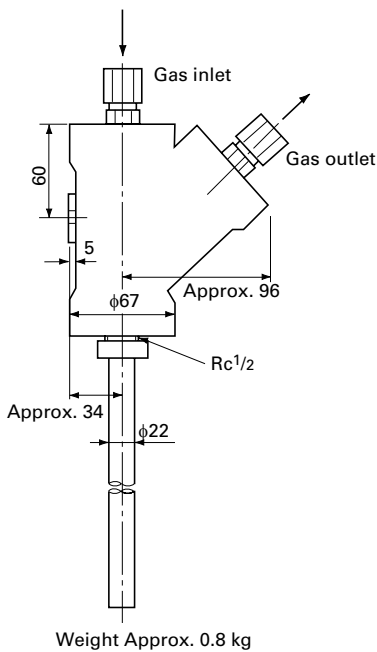
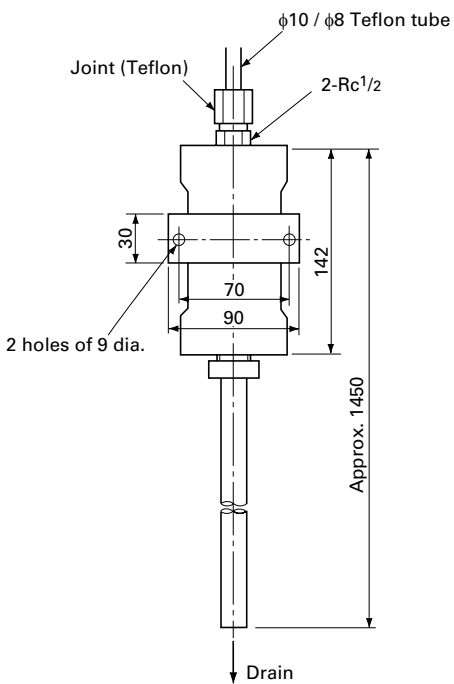

<Drain pot>

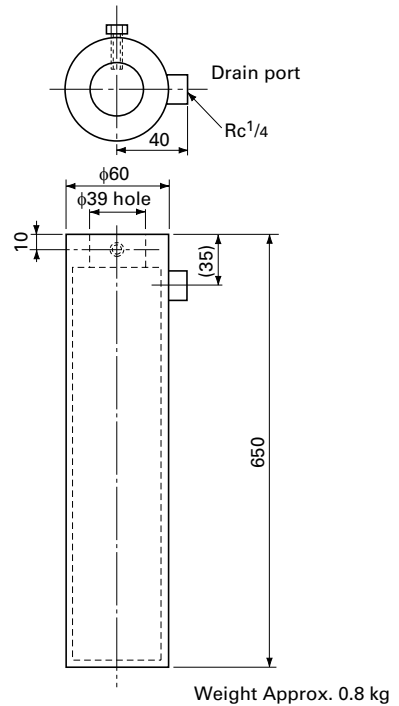

OUTLINE DIAGRAM (Unit: mm)

<Outdoor type>

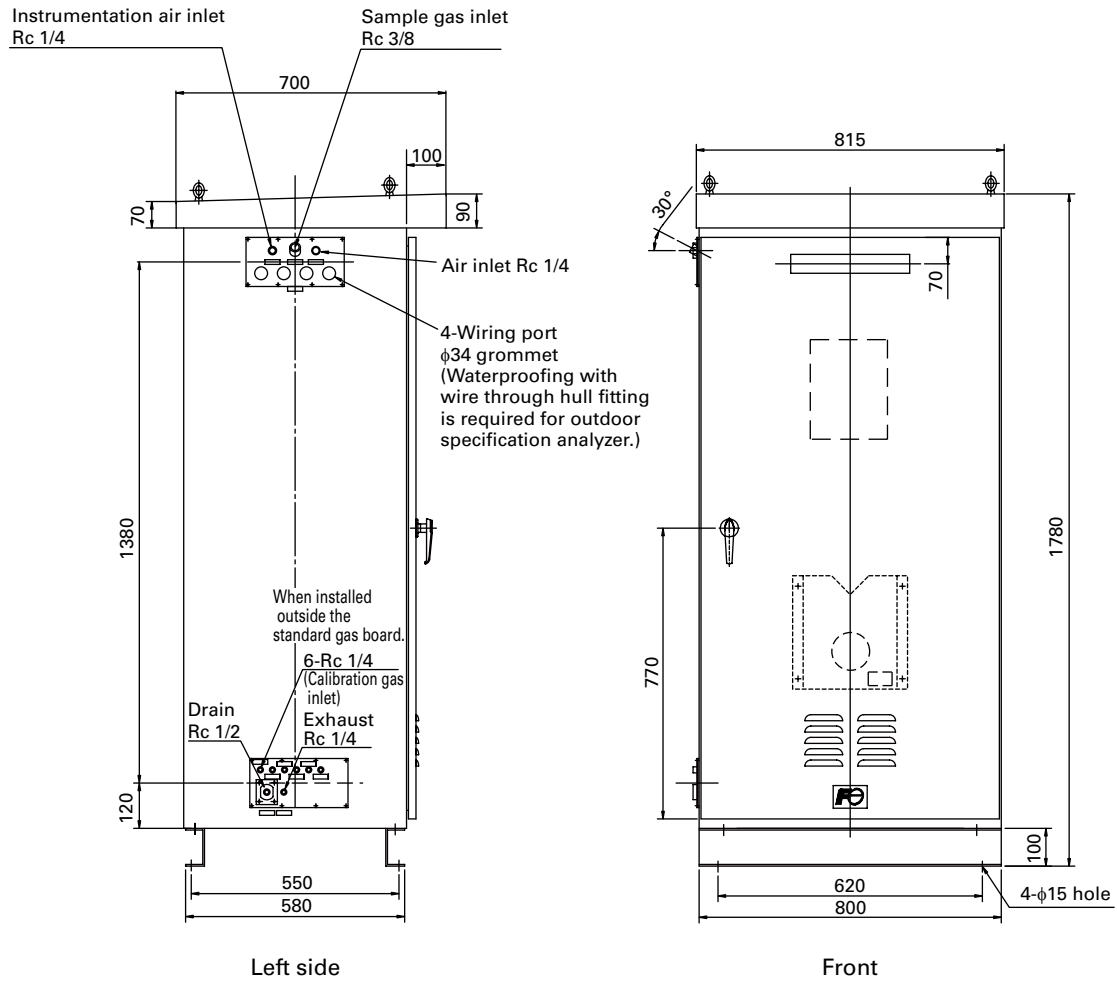

Anchor plan, door open/close diagram

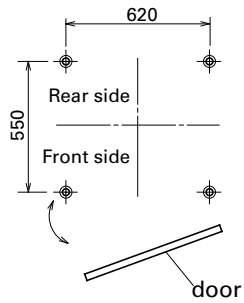

Anchor bolt (option)
(4-M12 \times 160 \times 50)

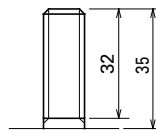

OUTLINE DIAGRAM (Unit: mm)

<Indoor type>

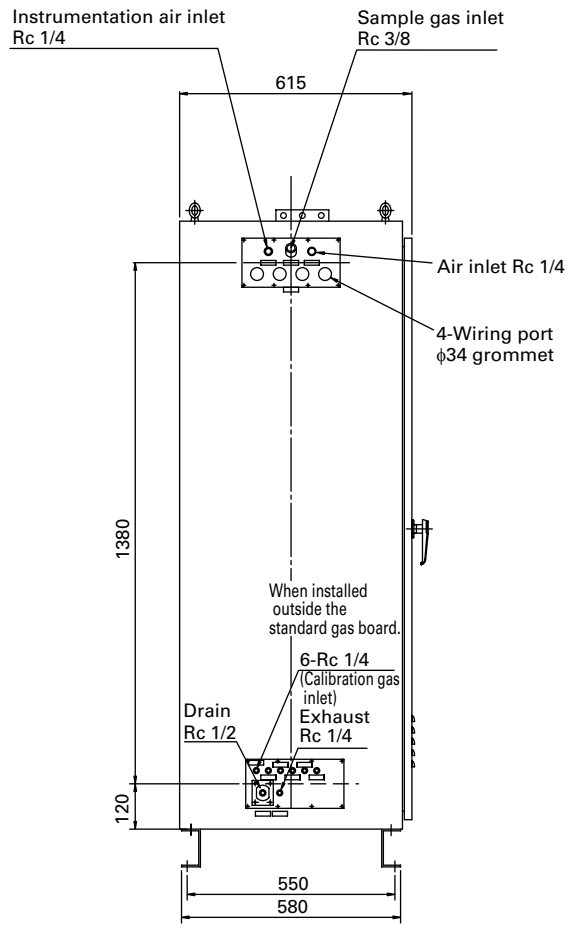

Left side

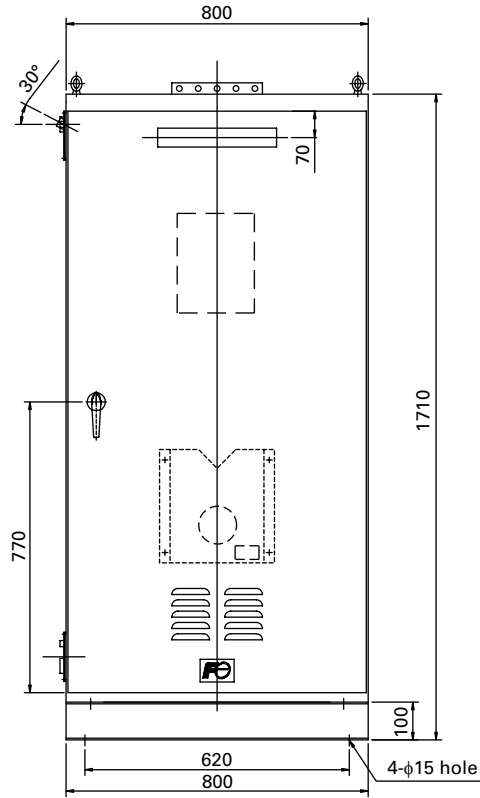

Front

Anchor plan, door open/close diagram

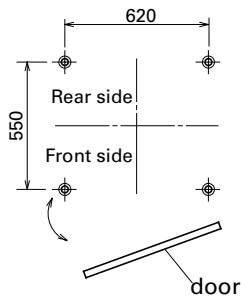

Anchor bolt (option)
(4-M12 × 160 × 50)

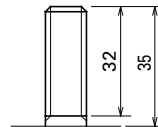

⚠ Caution on Safety

*Before using this product, be sure to read its instruction manual in advance.

Fuji Electric Systems Co., Ltd.

International Sales Div.1
Sales Group

Gate City Ohsaki, East Tower, 11-2, Osaki 1-chome,
Shinagawa-ku, Tokyo 141-0032, Japan

<http://www.fesys.co.jp/eng>

Phone: 81-3-5435-7280, 7281 Fax: 81-3-5435-7425

<http://www.fic-net.jp/eng>