



**Applicable flow pipe:**

Detector	Internal pipe diameter	Pipe material	Installation method	Fluid temperature range
FLSE12	ø25 to ø100mm	Plastic (PVC, etc.) Note 1	V	9th digit in code symbol Y...-20 to +100°C A...0 to +120°C
	ø50 to ø100mm	Metal (stainless steel, steel, copper, aluminum, etc.)		
FLSE22	ø50 to ø225mm Note 3	Plastic (PVC, etc.) Note 1		
		Metal (stainless steel, steel, copper, aluminum, etc.) Note 2		
FLSE31	ø50 to ø300mm	Plastic (PVC, PP, PVDF, etc.) Metal (stainless steel, steel, copper, aluminum, etc.) Note 2	V	-20 to 80C
FLSE41	ø300 to ø600mm	Plastic (PVC, PP, PVDF, etc.) Metal (stainless steel, steel, copper, aluminum, etc.) Note 2	Z	

- Note 1: Select FLSE31 or FLSE41 if the pipe is made of PP or PVDF. The wall thickness of PP pipe is 15 mm or less, and that of PVDF pipe is 9 mm or less.
- Note 2: Select FLSE31 or FLSE41 for the pipes that do not transmit ultrasound easily such as those made of cast iron, lining pipes, and old steel pipes.
- Note 3: When the 9th digit in the code symbol is "A", the applicable piping diameter is 50 to 150mm.

Liner: Tar epoxy, mortar, rubber, and others  
 Fundamental straight pipe:  
 10D for upstream and 5D for downstream (D: internal pipe diameter)  
 Refer to "Conditions on straight pipe" for details.

- Velocity:** 0 to ±0.3 ... ±10m/s
- Power supply:** 100 to 120V AC ±10%, 50/60Hz or 200 to 240V AC ±10%, 50/60Hz or 20 to 30V DC
- Signal cable:** Co-axial cable up to 30m and thermal stability of 100 deg.C
- Environment:** Non-explosive environment without direct sunlight, corrosive gas and heat radiation
- Ambient temperature:**  
 -20 to +50deg.C for flow transmitter  
 -20 to +60deg.C for detector
- Ambient humidity:**  
 90%RH or less
- Grounding:** Class D (100 Ω or less)
- Synchronization (option):**  
 Simultaneous transmission eliminates cross talk between multiple flow meters and mutual acoustic interference.  
 Number of connectable units: up to 31  
 Cable length: up to 15m  
 Master/Slave selectable
- Arrester (option):**  
 Arrester unit for outputs available (while arrester for power supply incorporated as standard)

**Performance specifications**

**Accuracy rating:**

**Plastic pipe**

Internal diameter	Velocity: 2m/s or higher	Velocity: Less than 2m/s
ø25 to ø50mm	±2.5% of rating	±0.05m/s
ø50 to ø600mm	±1.5% of rating	±0.03m/s

**Metal pipe**

Internal diameter	Velocity: 2m/s or higher	Velocity: Less than 2m/s
ø50 to ø600mm	±2% of rating	±0.04m/s

**Response time:** System cycle: 0.2s  
 Dead time: 0.2s or less, Time constant: 0.1s

**Power consumption:**  
 15VA or less for AC power supply  
 5W or less for DC power supply

**Permissible air volume rate:**  
 Up to 0.2% at 1 m/s (inversely proportional to velocity)

**Short-term thermal stability:**  
 140deg.C, 30min (in case FLSE□2)  
 Note: Use FLSE31/FLSE41 at the temperature of 80°C or lower.

## Functional specifications

- Analog output:** 4 to 20 mA DC (1 point)  
Max. load resistance : 600 Ω
- Digital output:** + total, - total, alarm, acting range, flow switch or total switch arbitrarily available  
Transistor open collector: 1 point (DO1)  
Capacity: 30V DC, 0.1A  
Normal off/on selectable  
Total pulse: 1pulse/day to 100pps (Pulse width: 5, 10, 50, 100 or 200ms)
- Mechanical relay contact: 1 point (DO2), with socket (exchangeable)  
Normal close/open selectable  
Capacity: 220V AC /30V DC, 1A (resistive load)  
Mechanical expected life: More than 2 x 10<sup>5</sup> operations (under rated load)  
Total pulse: 1pulse/day to 1pps (Pulse width: 50, 100 or 200ms)
- Communication interface (option):**  
RS-232C equivalent / RS-485  
Number of connectable units: one (RS-232C)/ up to 31 (RS-485)  
Baud rate: 2400/4800/9600/19200 bps selectable  
Parity: None/Odd/Even selectable  
Stop bit: 1 or 2 bits selectable  
Cable length: up to 15m (RS-232C)/up to 1km (RS-485)  
Data: Velocity, flow rate, forward total, reverse total, status, etc.
- Display device:** 2-color LED (Normal: green, Extraordinary: red)  
LCD with 2 lines of 16 characters and back light
- Display language:**  
English, Japanese, French, German or Spanish selectable
- Velocity/Flow rate display:**  
Instantaneous velocity/flow rate display (The flow of opposite direction is displayed by minus numerals.)  
Numeral: 7 digits (decimal point be counted as 1 digit)  
Unit: Metric/Inch system selectable

	Metric system	Inch system
Velocity	m/s	ft/s
Flow rate	L/s, L/min, L/h, kL/h, ML/d, m <sup>3</sup> /s, m <sup>3</sup> /min, m <sup>3</sup> /h, Mm <sup>3</sup> /d, BBL/s, BBL/min, BBL/h, MBBL/d	gal/s, gal/min, gal/h, kgal/h, Mgal/d, ft <sup>3</sup> /s, ft <sup>3</sup> /min, ft <sup>3</sup> /h, Mft <sup>3</sup> /d, BBL/s, BBL/min, BBL/h, MBBL/d

Note: The "gal" means USgal.

- Total display:** Display of forward or reverse total  
Numeral: 7digits (decimal point be counted as 1digit)  
Unit: Metric/Inch system selectable

	Metric system	Inch system
Total	mL, L, m <sup>3</sup> , km <sup>3</sup> , Mm <sup>3</sup> , mBBL, BBL, kBBL	gal, kgal, ft <sup>3</sup> , kft <sup>3</sup> , Mft <sup>3</sup> , mBBL, BBL, kBBL, ACRE-in, ACRE-ft

- Configuration:** Fully configurable from the 4-key pad (ESC, Δ, ▷, ENT) on the surface of flow transmitter's housing case by menu-driven software
- Zero adjustment:**  
Set Zero/Clear available
- Damping:** 0 to 100s (every 1s) configurable for analog output and display
- Low flow cut off :**  
0 to 5m/s configurable
- Alarm:** Hardware fault/Process fault applicable to digital output
- Burnout:** Analog output : Hold/Over-scale/Under-scale/Zero selectable  
Total: Hold/Count selectable  
Workingtimer: 0 to 100s (every 1s) configurable
- Bi-directional range:**  
Forward and reverse ranges configurable independently  
Hysteresis: 0 to 10% of acting range configurable  
Acting range applicable to digital output
- Auto-2 ranges:** Forward 2 ranges configurable independently  
Hysteresis: 0 to 10% of acting range configurable  
Acting range applicable to digital output
- Flow switch:** Lower and upper switching points configurable independently  
Acting point applicable to digital output
- Total switch:** +total switching point configurable  
Acting point applicable to digital output

## Physical specifications

- Enclosure protection:**  
Jetproof type (IP65) both for converter and detector (FLSE□2: When waterproof BNC connector is provided)  
FLSE□1: Immersion-proof type (IP67) (When the terminal block is filled with silicon rubber after wiring)
- Mounting:** Flow transmitter: Wall or 2B pipe mount  
Detector: Clamped on pipe surface
- Acoustic coupler:**  
Silicon rubber or silicon-free grease
- Material:** Flow transmitter: Plastic ABS  
Detector (type: FLSE□2):  
Plastic PBT for sensor housing, SUS304 for guide frame  
Detector (type: FLSE□1):  
Plastic PBT for sensor housing, SUS304 for sensor cover, SUS304 and PBT for guide rail
- Sensor cable:** 3D2V with outside diameter 5mm
- Dimensions:** Flow transmitter: H140 x W137 x D68mm  
Detector: H50 x W228 x D34mm (FLSE1)  
H50 x W348 x D34mm (FLSE2)  
H40 x W500 x D80mm (FLSE3: mounting V method)  
H40 x W72 x D60mm (FLSE4: mounting Z method)
- Mass:** Flow transmitter: 0.8kg  
Detector: 0.3kg (FLSE1) / 0.4kg (FLSE2)  
1kg (FLSE3: mounting V method)  
0.4kg (FLSE4: mounting Z method)

Conditions on straight pipe

( D : Inside diameter of pipe)

Classification	Upstream side	Downstream side
90 bend		
Tee		
Diffuser		
Reducer		
Various Valve	<p>In case that flow control valve exists on upstream side.</p>	<p>In case that flow control valve exists on downstream side.</p>
Pump		

(Note) The source : JEMIS-032

## MEASURING PRINCIPLE

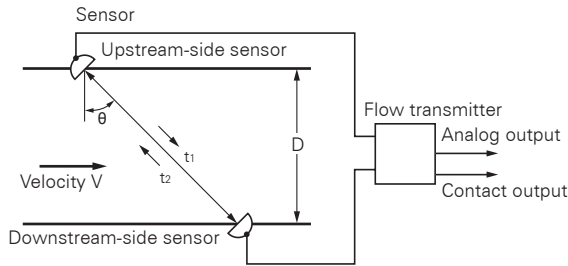

The transit-time technique uses a pair of sensors with each sensor sending and receiving ultrasonic signals obliquely through the fluid.

## CONFIGURATION

### (1) Single-path system (V method)

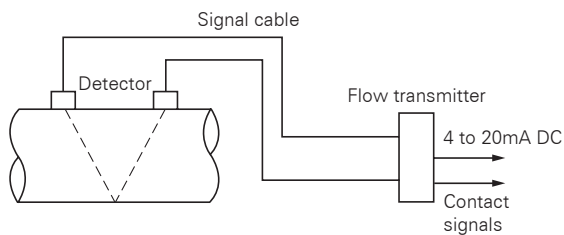

### (2) Single-path system (Z method)

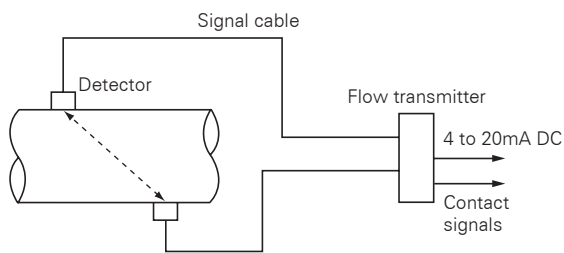

### (3) When using synchronization

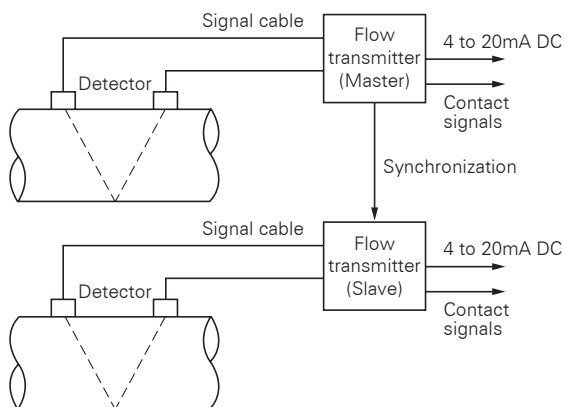

### <Dedicated Signal cable>

1	2	3	4	5	6	7	8	Description
F	L	Y					1	Type (4th digit)
			3					Heat-resistant cable with one-side waterproof BNC connector for FLSE12 and FLSE22
			4					Heat-resistant cable for FLSE31 and FLSE41
								Cable length (5th to 7th digit)
				0	0	5		5m
				0	1	0		10m
				0	1	5		15m
				0	2	0		20m
				0	3	0		30m
							1	Modification No. (8th digit)
								Mark 1

## CODE SYMBOLS

### <Flow Transmitter>

1	2	3	4	5	6	7	8	9	10	11	12	Description
F	L	R	E				2	-	1			Type (4th digit)
			E									Standard for exports
				2								Power Supply (5th digit)
				3								100 to 120Vac, 50/60Hz
				4								200 to 240Vac, 50/60Hz
												20 to 30Vdc
					Y							Communication and Synchronization (6th digit)
					A							None
					B							RS-232C
					C							RS-485 and Synchronization Synchronization
						Y						Arrester (7th digit)
						A						None
												With arresters for outputs
							2					Modification No. (8th digit)
												Mark 2
								1				Case structure (9th digit)
												Jetproof type (IP65)
									A			Mounting bracket (10th digit)
									B			For 2B pipe mount
												For wall mount
										Y		Parameter setting, tag plate (11th digit)
										A		Without
										B		With setting
										C		With setting (Tag plate)
												With Tag plate
											A	Detector (12th digit)
												FLSE12, FLSE22
												FLSE31, FLSE41

(Note) This type has not so tough endurance against aeration as Fuji's general use ultrasonic flowmeters TIME DELTA-S/F (Model: FLV/FLH) and PORTAFLOW-X (Model: FLC). For applications containing air bubbles, those general use flowmeters are recommendable to be used.

### <Detector>

1	2	3	4	5	6	7	8	9	10	Description
F	L	S	E				3	-	Y	Type (4th digit)
			E							Standard
				1	2					Kind of detector (5th to 6th digit)
				2	2					Small-dia. detector (ø25 to ø100 mm)
				3	1					Small detector (ø50 to ø225 mm) *1
				4	1					Small detector (ø50 to ø300 mm)
										Small detector (ø300 to ø600 mm) Z method
										Acoustic coupler (7th digit) (Note)
										None
										Silicon rubber
										(Fluid temperature: -20 to +100 deg.C)
										Silicon-free grease
										(Fluid temperature: 0 to +60 deg.C)
										Modification No. (8th digit)
										Mark 2
										Option (10th digit)
										Without
										Tag plate

\*1) When the 9th digit in the code symbol is "A", the applicable piping diameter is 50 to 150mm.

(Note) In case FLSE□2, select silicon rubber (A) for acoustic coupler in ordinary cases. Silicon rubber is supplied in a tube (100g). If one or more detectors are ordered, silicon rubber may be selected once every 5 orders or so.

Select silicon-free grease (B) for the use in an environment where generation of silicon is not desirable such as semiconductor manufacturing facilities. The silicon-free grease is soluble in water. Therefore, do not use it in an environment subject to splash of water or where condensation tends to occur on the surface of the piping. The grease, which does not become hardened, requires periodic maintenance (cleaning and refilling of about once in 6 months at room temperature).

## OUTLINE DIAGRAM (Unit:mm)

### <Flow transmitter (type: FLR)>

\* PIPE MOUNT (OPTION)

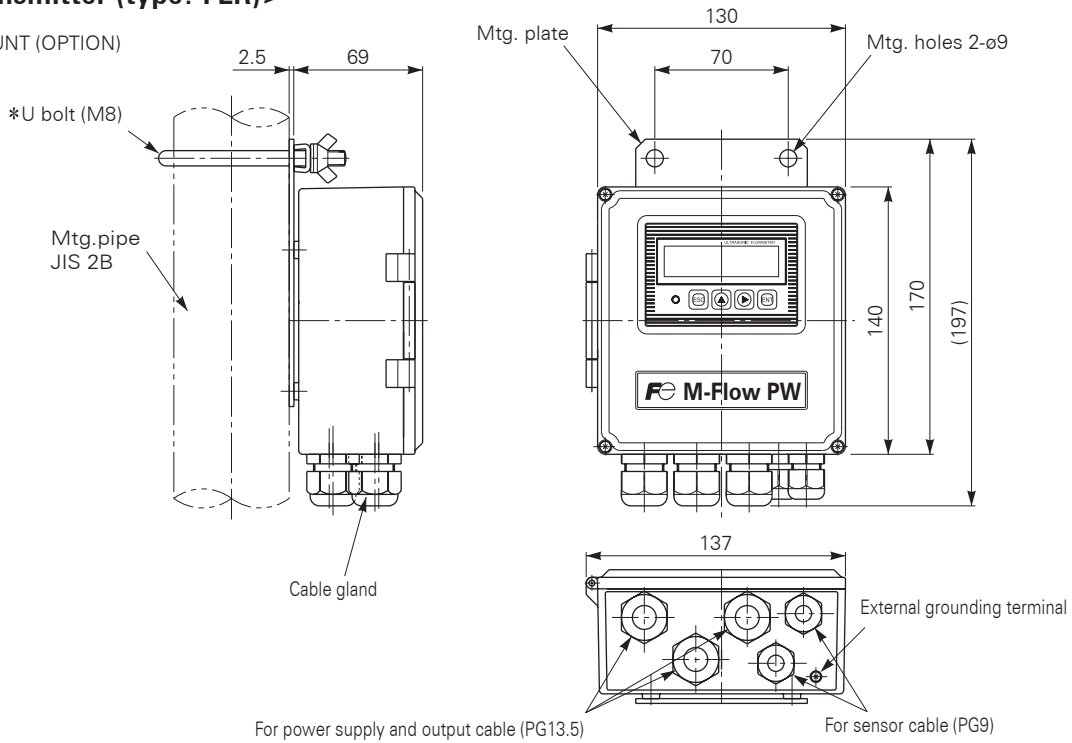

## CONNECTION DIAGRAM

AC power supply

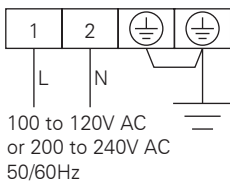

DC power supply

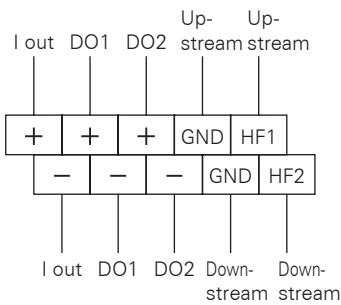
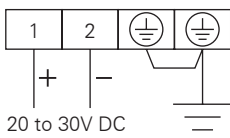

(Note)  
DO1 : Transistor open collector  
DO2 : Mechanical relay contact

RS-485 and Synchronization

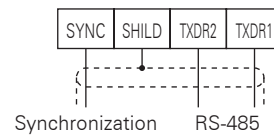

RS-232C

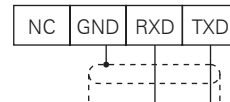

### <Detector (type: FLSE<sub>2</sub>)>

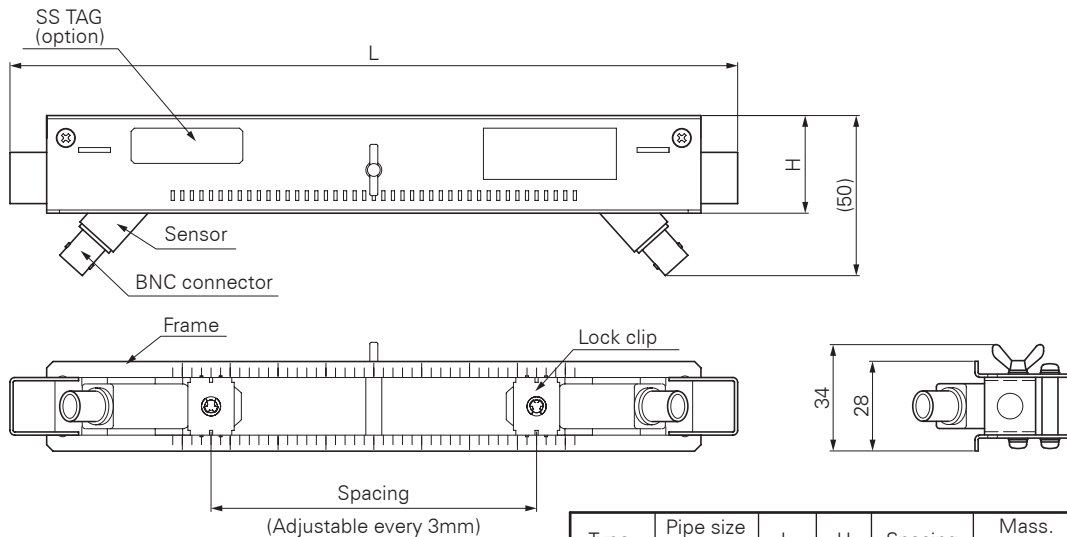

Type	Pipe size (mm)	L	H	Spacing	Mass. approx (kg)
FLSE12	25 to 100	228	31	21 to 120	0.3
FLSE22	50 to 225	348	30	21 to 240	0.4

<Detector (type: FLSE31 V METHOD)>

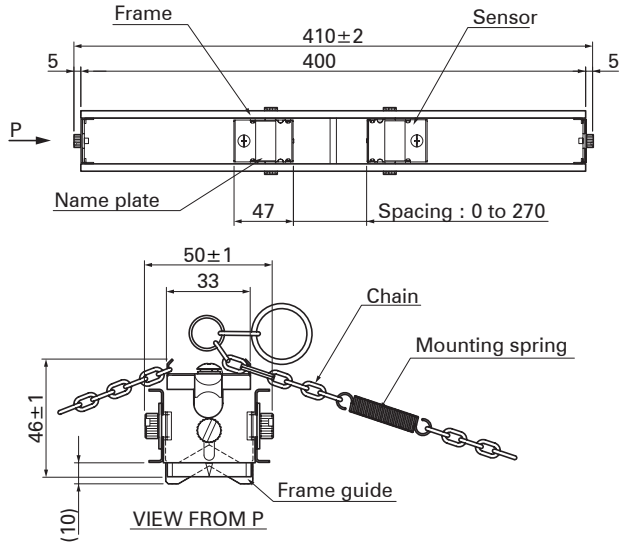

Connection diagram

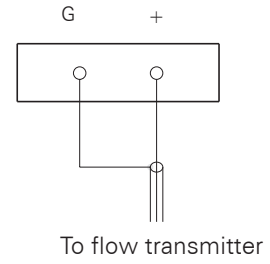

<Detector (type: FLSE41 Z METHOD)>

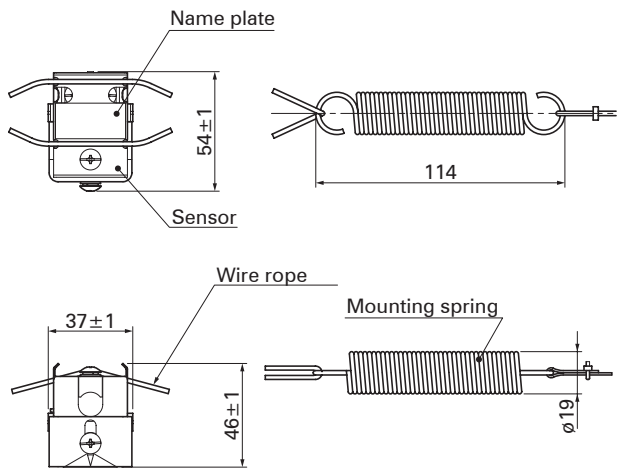

Connection diagram

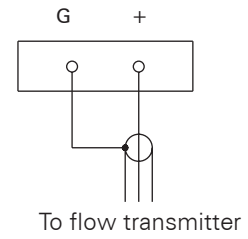

<Signal cable (type: FLY30)>

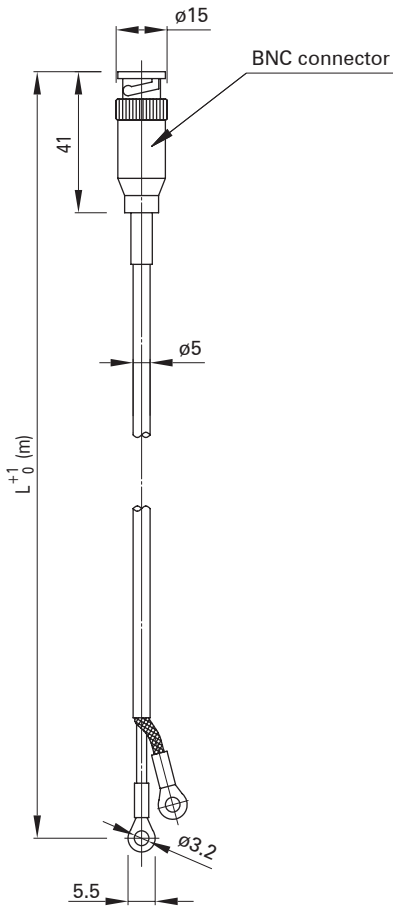

Type	L (m)	Mass. approx. (kg) <sup>*Note1</sup>
FLY3005	5	0.6
FLY3010	10	1.2
FLY3015	15	1.8
FLY3020	20	2.4
FLY3030	30	3.6

\*Note1: Total of two elements

<Signal cable (type: FLY40)>

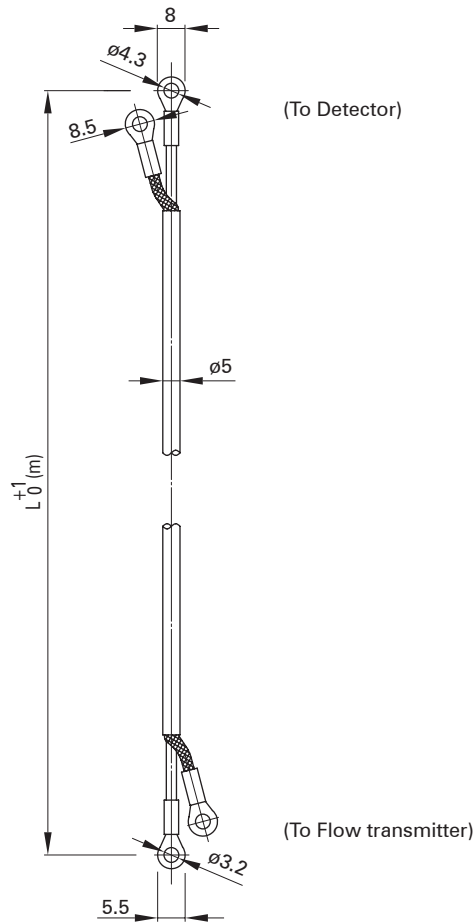

Type	L (m)	Mass. approx. (kg) <sup>*Note1</sup>
FLY4005	5	0.6
FLY4010	10	1.2
FLY4015	15	1.8
FLY4020	20	2.4
FLY4030	30	3.6

\*Note1: Total of two elements

**SCOPE OF DELIVERY**

- Flow transmitter FLR: • Flow transmitter  
• Instruction manual
- Detector FLS: • Sensor unit  
• Mounting fixtures  
• Silicon rubber or Silicon-free grease (option)
- Signal cable FLY : • Cable (one pair)

The product conforms to the requirements of the Electromagnetic compatibility Directive 89/336/EEC as detailed within the technical construction file number TN513321. The applicable standards used to demonstrate compliance are :

EN 61326 : 1998  
Electrical equipment for measurement, control and laboratory use —  
EMC requirements

⚠ Caution on Safety

\*Before using this product, be sure to read its instruction manual in advance.

**Fuji Electric Systems Co., Ltd.**

International Sales Div.1

Sales Group

Gate City Ohsaki, East Tower, 11-2, Osaki 1-chome, Shinagawa-ku, Tokyo 141-0032, Japan

http://www.fesys.co.jp/eng

Phone: 81-3-5435-7280, 7281 Fax: 81-3-5435-7425

http://www.fic-net.jp/eng