

# HYBRID ULTRASONIC FLOWMETER <Duosonics> (Pulse Doppler method + Transit Time method)

DATA SHEET

FSH, FSW, FLY

This meter is the world's first non-intrusive type ultrasonic flowmeter utilizing Pulse Doppler method along with Transit Time method. It enables measurement of velocity profile directly resulting in high accuracy. This makes it suitable for undeveloped flow and for short straight pipes. Pulse Doppler method requires reflectors in the liquid and is utilized on opaque liquids while Transit Time method requires ultrasound penetration and is ideal for clean liquids. The new hybrid technology utilizes both methods in a complementary fashion thus enabling a wider range of applications than it is possible now. In addition, thanks to Fuji's new state-of-the-art algorithm, either method can be automatically switched to accommodate for varying fluid conditions such as concentration of particles and/or air bubbles and flow velocity.

## FEATURES

- Automatic switchover function between Pulse Doppler method utilizing ultrasound reflection and Transit Time method utilizing ultrasound penetration**
  - Applicable to various kinds of liquids with/without air bubbles and/or solid particles
  - Applicable to liquid flow that changes in nature frequently or periodically
- High-accuracy non-intrusive (non-contact) volumetric flow rate measurement of liquid flow in closed pipes.**
  - Accuracy of 0.5% to 1% (depending on the measuring mode and pipe size)
  - Clamp-on sensor
- Direct measurement of velocity profile in case of Pulse Doppler method**
  - High accuracy of 0.5% to 1.5% (correction coefficient unnecessary)
  - Applicable to undeveloped flow (short straight pipe)
  - Applicable to flow hovering in the transitional region between laminar flow and turbulent flow
- High speed response: 0.2sec (pulse Doppler method)/ 0.5sec (transit time method)**
- Real time monitoring of velocity profile by PC in case of Pulse Doppler method (option)**
- Dual-path option improves performance**

## SPECIFICATIONS

### Operational specifications

#### System configuration:

The system is composed of one/two detectors (Model: FSW) and one Flow transmitter (Model: FSH), realizing single-path/two-path measurement.

Hybrid mode or transit time mode is selectable.

In case of hybrid mode, either Pulse Doppler method or transit time method is automatically selected depending on conditions of measured liquid and magnitude of velocity.



Flow transmitter (FSH)

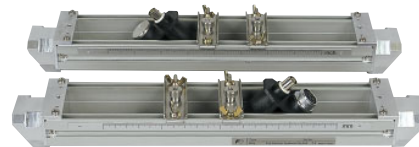

Detector (FSW)

**Application:** Uniform liquid in which ultrasonic waves can propagate.

**Air bubble quantity:** Pulse Doppler method: 0.02 to 15% of volume at 1 m/s  
Transit time method: 0 to 12% of volume at 1 m/s

**Fluid temperature:** -40 to +100°C (FSW12), -40 to 80°C (FSW21, FSW40, FSW50)

**Type of flow:** Pulse Doppler method: axisymmetric flow in a filled pipe.  
Transit time method: well-developed turbulent or laminar flow in a filled pipe.

#### Applicable flow pipe:

**Material:** Plastics (PVC, FRP, etc.) or Metals (carbon steel, SS, copper, aluminum, etc.)

**Pipe size:** 40 to 1000 mm (inside diameter)

**Liner:** Tar epoxy, mortar, etc.

**Straight pipe length:** Typically 10D for upstream and 5D for downstream. Refer to JEMIS-032 in detail.

(Note) JEMIS: Japan Electric Measuring Instruments Manufacturers' Associations Standard

**Velocity:** Hybrid mode: 0 to  $\pm 0.3$  —  $\pm$ Maximum Velocity (depending on pipe diameter) (Note) Maximum measurement range in Hybrid mode (see page 4)

Transit time mode: 0 to  $\pm 0.3$  —  $\pm 32$  m/s

#### Power supply:

100 to 240 Vac+10%/-15%, 50/60Hz or 20 to 30 Vdc

**Signal cable:** Single-path system :  
 A pair of RF co-axial cables for ultrasound signals and a three-core shield cable for temperature sensor,  
 Two-path system: Two pairs of RF co-axial cables for ultrasound signals and a three-core shield cable for temperature sensor,  
 Maximum cable length: 150m  
 Temperature range: 80°C

**Environment:** Non-explosive environment without direct sunlight, corrosive gas and heat radiation

**Ambient temperature:**  
 -10 to +50°C for flow transmitter,  
 -20 to +80°C for detector

**Ambient humidity:**  
 95%RH or less for flow transmitter, 100%RH or less for detector

**Grounding:** Class D (less than 100 ohm)

**Arrester:** Surge absorbers for outputs and power supply incorporated as standard

**Performance specifications**

**Accuracy :**

**Pulse Doppler method :**

Pipe size (inside diameter) and detector	Velocity	Accuracy
φ40mm to φ50mm or less (Detector: FSWS12)	1.5 m/s to Max. Velocity (Note)	±1.0% of rate
	0 m/s to 1.5 m/s	±0.015m/s
φ50mm to φ200mm (Detector: FSWS12)	1.5 m/s to Max. Velocity (Note)	±0.5% of rate
	0 m/s to 1.5 m/s	±0.0075m/s
φ100mm to φ1000mm (Detector: FSWS21,40,50)	1 m/s to Max. Velocity (Note)	±1.0% of rate
	0 m/s to 1 m/s	±0.01m/s

(Note) Maximum velocity is depend on a pipe diameter.  
 See Maximum measurement range in Hybrid mode (page 4).

**Transit time method :**

Pipe size (inside diameter)	Velocity	Accuracy
φ40mm to φ50mm or less	2 m/s to 32 m/s	±1.5% of rate
	0 m/s to 2 m/s	±0.03m/s
φ50mm to φ300mm or less	2 m/s to 32 m/s	±1.0% of rate
	0 m/s to 2 m/s	±0.02m/s
φ300mm to φ1000mm	1 m/s to 32 m/s	±1.0% of rate
	0 m/s to 1 m/s	±0.01m/s

**Response time:**

Pulse Doppler method: 0.2sec  
 (depending on pipe diameter and measuring condition)

Transit time method: 0.5sec

**Power consumption:**

20W or less

**Short-term thermal stability:**

140°C, 30 min (FSWS12),  
 100°C, 30 min (FSWS21, FSWS40, FSWS50)

**Functional specifications**

**Analog output:** 4 to 20 mAdc (1 point)  
 Max. load resistance: 1k ohm

**Digital output:** +total, -total, alarm, acting range, flow switch or total switch – arbitrarily selectable

Mechanical relay contact:

1 point with socket (replaceable)  
 Normally closed/open selectable  
 Capacity:240 Vac/30 Vdc, 1 A  
 Total pulse: less than 1 p/s  
 (Pulse width: 50, 100 or 200 ms selectable)

Transistor open collector: 2 points

Capacity: 30 Vdc, 0.1 A  
 Normally off/on selectable  
 Total pulse: less than 1000 p/s  
 (Pulse width: 0.5, 1, 2, 5, 10, 20, 50, 100 or 200 ms selectable)

**Communication interface:**

RS-232C equivalent / RS-485 (selectable)  
 Number of connectable units: one (RS-232C)/ up to 31 (RS-485)  
 Baud rate: 9600/19200/38400 bps selectable  
 Parity: none/odd/even selectable  
 Stop bit: 1 or 2 bits selectable  
 Distance: up to 15 m (RS-232C)/up to 1k m (RS-485)  
 Data: velocity, flow rate, +total, -total, status (standard), velocity profile (option)

**Display device:**

Graphic LCD (number of pixels: 240x64) with back light,

**Display language:**

Japanese, English, French, German or Spanish selectable

**Velocity/Flow rate display:**

Display of velocity and/or flow rate with flow direction  
 Data: up to 10 digits (decimal point to be counted as 1 digit)  
 Unit: Metric/English system selectable

	Metric system	English system
Velocity	m/s	ft/s
Flow rate	L/s, L/min, L/h, L/d, kL/h, ML/d, m <sup>3</sup> /s, m <sup>3</sup> /min, m <sup>3</sup> /h, m <sup>3</sup> /d, km <sup>3</sup> /d, Mm <sup>3</sup> /d, BBL/s, BBL/min, BBL/h, kBBL/d, MBBL/d	ft <sup>3</sup> /s, ft <sup>3</sup> /min, ft <sup>3</sup> /h, Mft <sup>3</sup> /d, gal/s, gal/min, gal/h, Mgal/d, BBL/s, BBL/min, BBL/h, BBL/d, kBBL/d, MBBL/d

Note: "gal" means US gal.

**Total display:** Display of forward or reverse total

Data: up to 10 digits (decimal point to be counted as 1 digit)  
 Unit: Metric/English system selectable

	Metric system	English system
Total	mL, L, m <sup>3</sup> , km <sup>3</sup> , Mm <sup>3</sup> , mBBL, BBL, kBBL	ft <sup>3</sup> , kft <sup>3</sup> , Mft <sup>3</sup> , gal, kgal, mBBL, BBL, kBBL, ACRf

**Configuration:**

Fully configurable on keyboard by menu-driven software

**Zero adjustment:**

Set zero/Clear available. (transit time method)

**Damping:** 0 to 100s (every 0.1s) configurable for analog output and display

**Low flow cut off:**

0 to 5 m/s configurable

**Alarm:** Hardware fault/process fault can be tied to digital output

**Burnout:** Analog output: Hold/Upper limit/Lower limit/  
Zero/Not-used selectable  
Total: Hold/Count selectable  
Timer: 0 to 900s (every 1s) configurable

**Bi-directional range:**  
Forward and reverse ranges configurable independently  
Hysteresis: 0 to 20% of working range configurable  
Working range applicable to digital output

**Auto-2 ranges:**  
Forward 2 ranges configurable independently  
Hysteresis: 0 to 20% of working range configurable  
Working range applicable to digital output

**Flow switch:** Lower and upper switching points configurable independently  
Acting point applicable to digital output

**Total switch:** +total switching point configurable  
Acting point applicable to digital output

**Acoustic coupler:**  
Silicon compound (RTV)

**Material:**  
Flow Transmitter: aluminum alloy  
Detector: PBT for housing, aluminum alloy for frame and SS for fastening belt

**Sensor cable(FLY6):**  
RF coaxial cable (double shielded)  
External sheath: Black flame-resistant vinyl  
External diameter: About 7.3 mm  
Terminal treatment: Water-resistant BNC connector (detector side), M3.5 amplifier terminal (Flow Transmitter side)  
Weight: About 90 g/m

**Temperature sensor cable(FLY7):**  
3-core shield cable  
External sheath: Gray flame-resistant vinyl  
External diameter: About 6.9 mm  
Terminal treatment: Round waterproof connector (detector side), M3.5 amplifier terminal (Flow Transmitter side)  
Weight: About 56 g/m

**Physical specifications**

**Enclosure protection:**  
Flow Transmitter: IP67,  
Detector: IP67

**Mounting:** Flow Transmitter: wall mount  
Detector: clamped on pipe surface

**Dimensions:** Flow Transmitter : H240 x W247 x D134 mm  
Detector: H70 x W57 x L360 mm (FSWS12)  
H72 x W57 x L540 mm (FSWS21)  
H90 x W85 x L640 mm (FSWS40)  
H82 x W71 x L258 mm (FSWS50)

**Mass:** Flow Transmitter: 5 kg  
Detector: 1.7 kg (FSWS12), 1.9 kg (FSWS21),  
5 kg (FSWS40), 1.5 kg (FSWS50)

**Conditions on straight pipe**

( D : Inside diameter of pipe)

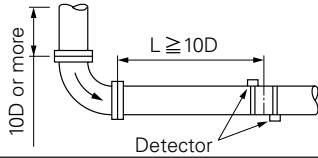
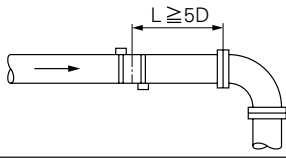
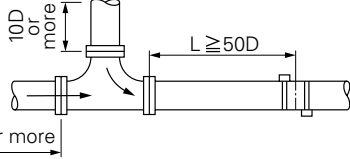
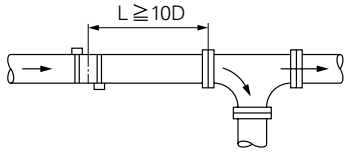
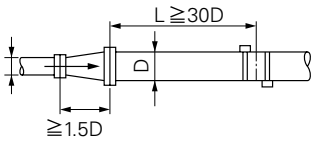
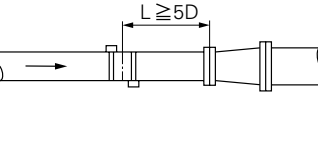
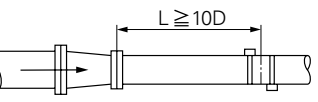
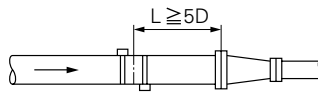
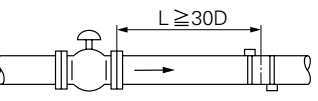
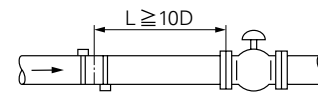
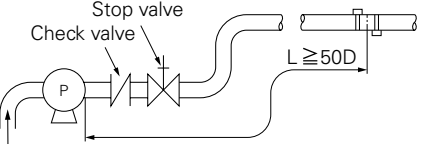
Classification	Upstream side	Downstream side
90 bend		
Tee		
Diffuser		
Reducer		
Various Valve	 In case that flow control valve exists on upstream side.	 In case that flow control valve exists on downstream side.
Pump		

(Note) The source : JEMIS-032

## Measurement principle

### <Pulse Doppler method>

- Ultrasound pulses are transmitted into a liquid, and flow velocity profile is found and the flow rate is measured by using the characteristics that Doppler frequency of the echo from reflectors such as air bubbles and particles in the liquid changes according to flow velocity.

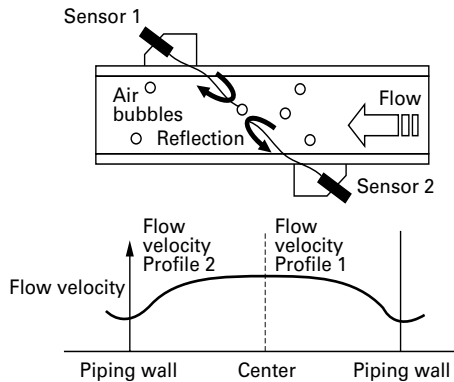

### <Transit Time method>

- Ultrasound pulses are propagated slanted both from the upstream and downstream, and flow rate is measured by detecting the time difference generated with the flow.

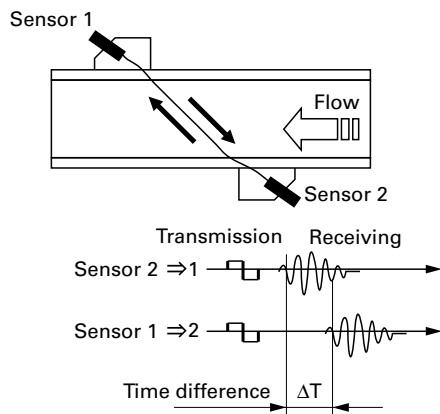

### Maximum measurement range in hybrid mode

When stainless steel is selected as pipe material, nominal wall thickness is Sch20s, and the fluid is water

<Maximum measurable flow velocity>

Unit: m/s

Caliber	FSWS12	FSWS21	FSWS40	FSWS50
40A	6.56			
50A	6.52			
65A	5.31			
80A	4.65			
90A	4.12			
100A	3.69	7.25		
125A	3.08	6.08		
150A	2.63	5.20		
200A	2.04	4.05	7.77	
250A		3.30	6.38	
300A		2.78	5.41	
350A		2.51	4.90	
400A		2.20	4.31	
450A			3.80	
500A			3.48	3.48
550A				3.17
600A				2.91
650A				2.71
700A				2.52
750A				2.35
800A				2.21
850A				2.08
900A				1.97
1000A				1.77

## Block diagram

### (1) Single path system (Z method)

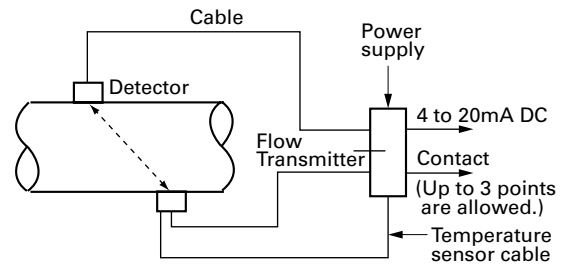

### (2) 2-path system (Z method)

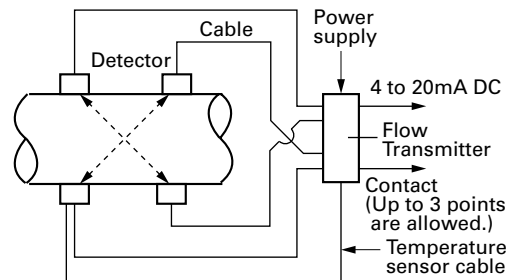

<Maximum measurable flow rate>

Unit: m<sup>3</sup>/h

FSWS12	FSWS21	FSWS40	FSWS50
33.6			
52.7			
72.1			
86.5			
102			
118	231		
147	289		
179	354		
239	474	908	
	604	1168	
	735	1428	
	820	1598	
	951	1858	
		2118	
		2358	2358
			2618
			2879
			3096
			3357
			3618
			3879
			4140
			4400
			4902

# CODE SYMBOLS

## <Flow transmitter>

1	2	3	4	5	6	7	8	9	10	11	12
F	S	H		Y	1	-	S	Y	Y		
Description											
Type (4th digit)											
Standard											
Velocity profile output (5th digit)											
None											
Available											
Use (6th digit)											
Single path or Changeover two-path (Note)											
Note: 2 sets of detectors and coaxial cables (FLY6) needed for two-path system.											
Power supply (7th digit)											
100 to 240 Vac, 50/60 Hz											
20 to 30 Vdc											
Modification No. (8th digit)											
Mark 1											
Case structure (9th digit)											
IP67											
Conduit connection (10th digit)											
G1/2 and G3/8 (female screw) with water-proof connection											
For use with explosion-proof detector (11th digit)											
None											
Parameter setting, Tag Plate (12th digit)											
Y --- None											
A --- With setting											
B --- With setting and Tag Plate											
C --- With Tag Plate											

## <Signal cable>

1	2	3	4	5	6	7	8
F	L	Y				1	
Description							
Kind of cable (4th digit)							
Coaxial cable (for ultrasonic sensors)							
Three-core cable (for temperature sensor)							
Cable length (5th to 7th digit)							
0 0 5				5m			
0 1 0				10m			
0 1 5				15m			
0 2 0				20m			
0 2 5				25m			
0 3 0				30m			
0 3 5				35m			
0 4 0				40m			
0 4 5				45m			
0 5 0				50m			
0 5 5				55m			
0 6 0				60m			
0 6 5				65m			
0 7 0				70m			
0 7 5				75m			
0 8 0				80m			
0 8 5				85m			
0 9 0				90m			
0 9 5				95m			
1 0 0				100m			
1 1 0				110m			
1 2 0				120m			
1 3 0				130m			
1 4 0				140m			
1 5 0				150m			
Length in m to be designated with 3 digits							
Modification No. (8th digit)							
1				Mark 1			

## <Detector>

1	2	3	4	5	6	7	8	9	10	11
F	S	W	S		0	1	-	Y		
Description										
Type (4th digit)										
Standard										
Kind of detector (5th and 6th digit)										
1 2				Small diameter detector (φ 40 to 200 mm)						
2 1				Small size detector (φ 100 to 400 mm)						
4 0				Middle size detector (φ 200 to 500 mm)						
5 0				Large size detector (φ 500 to 1000mm)						
Use (7th digit)										
0				Standard (IP67)						
Modification No. (8th digit)										
1				Mark 1						
Signal cable (9th digit)										
Y				None						
Acoustic coupler (10th digit) (Note)										
Y				None						
A				Silicone compound						
Option (11th digit)										
Y				None						
A				Tag Plate						

(Note) Select silicone compound (A) for acoustic coupler in ordinary cases. Silicon compound is supplied in a tube (150g). If one or more detectors are ordered, silicon compound may be selected once every 5 orders or so.

## Loader software for PCs

Equipped as standard

- Works on PC/AT compatible machines.
- Operation on PC98-series machines (NEC) cannot be guaranteed.
- Operation on self-made PCs or shop-brand PCs cannot be guaranteed.
- Major functions: Setting/changing of various parameters for the main unit

If no flow velocity profile output is selected, the following functions are not available.

"Detailed setting" and "flow velocity profile display" in pulse Doppler measurement  
 "Detailed setting" and "received signal display" in Transit time measurement

- O/S: Windows2000/XP
  - Memory requirement: 128MB or more
  - Disk unit: Windows2000/XP-compatible CD-ROM drive
  - Hard disk drive capacity: Free space of 52MB or more
- Note: PC loader communication cable (type ZP\*TK4H6253, Specifications: D-sub 9 pin receptacle, cable length 3m) is separately required.

## Detector frame installation fixture

Installation fixture is provided to facilitate the positioning of the frame to the piping.

Select a desired type from the following according to the detector to be used.

Type	Applicable detector
ZP*TK7M7071C1	FSWS12
ZP*TK7M7071C2	FSWS21
ZP*TK7M7071C3	FSWS40

Note: The installation fixture cannot be used for detector type FSWS50, which is not provided with a frame.

# OUTLINE DIAGRAM (Unit:mm)

<Flow transmitter (type: FSH)>

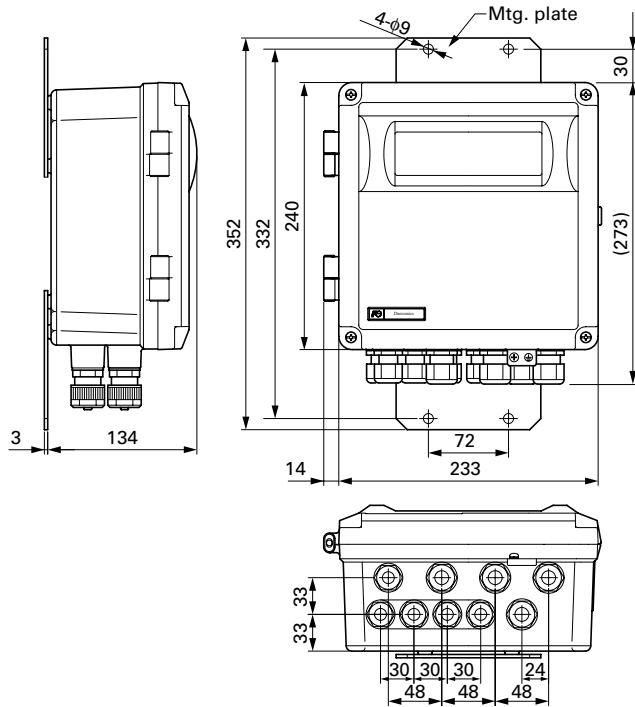

## CONNECTION DIAGRAM

Power supply terminals (AC)

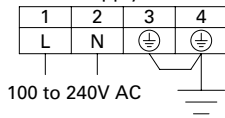

Power supply terminals (DC)

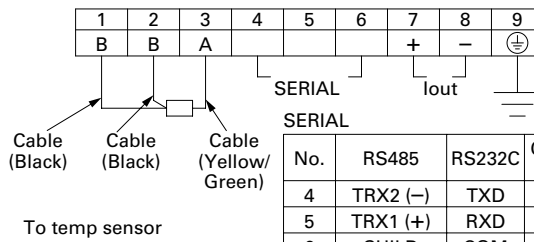
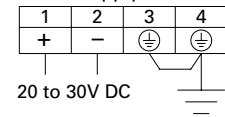

No.	RS485	RS232C	Communication cable (option)
4	TRX2 (-)	TXD	Cap (red)
5	TRX1 (+)	RXD	Cap (yellow)
6	SHILD	COM	Cap (black)

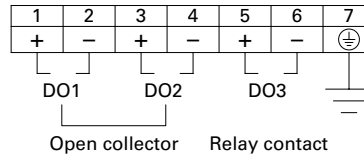
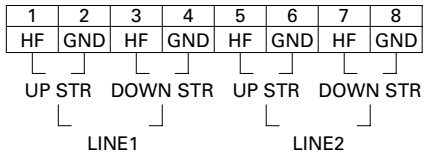

\* Use LINE1 terminals in case of single measuring path.

# OUTLINE DIAGRAM (Unit:mm)

<Detector (type: FSWS12, 21)>

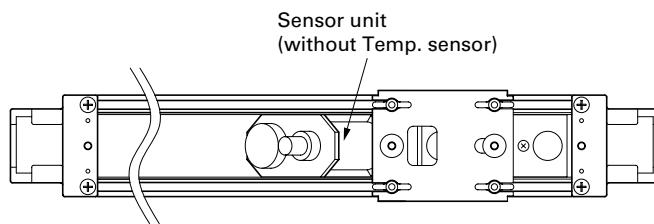
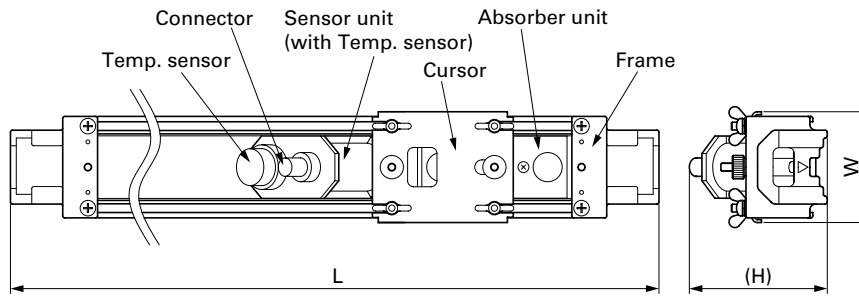

TYPE	PIPE SIZE	L	H	W	MASS APPROX
FSWS12	ø40~ø200	360	70	57	1.7
FSWS21	ø100~ø400	540	72	57	1.9

<Detector (type: FSWS40)>

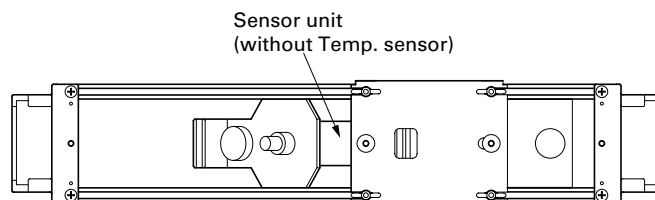
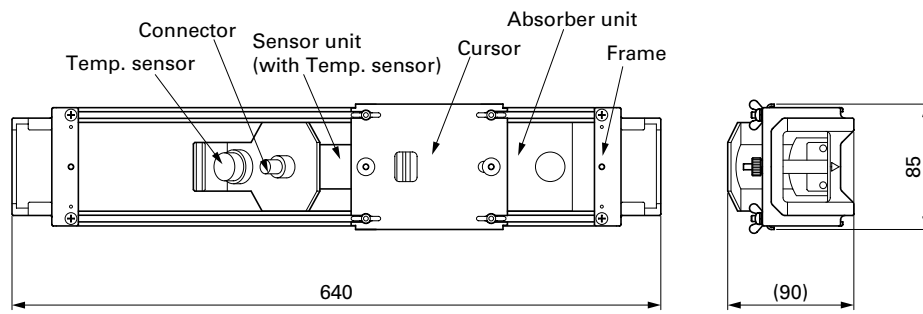

# OUTLINE DIAGRAM (Unit:mm)

<Detector (type: FSWS50)>

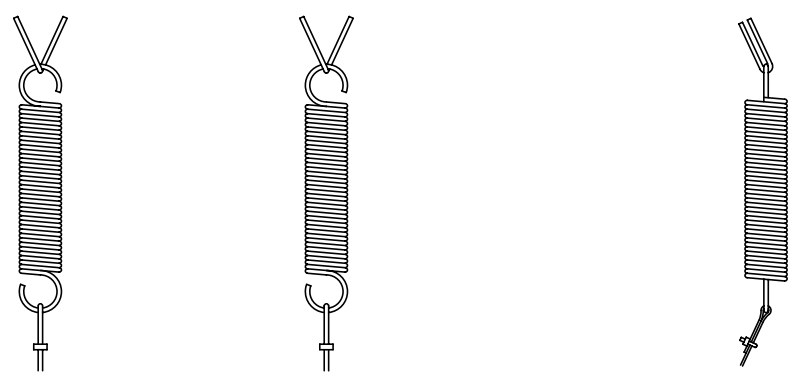
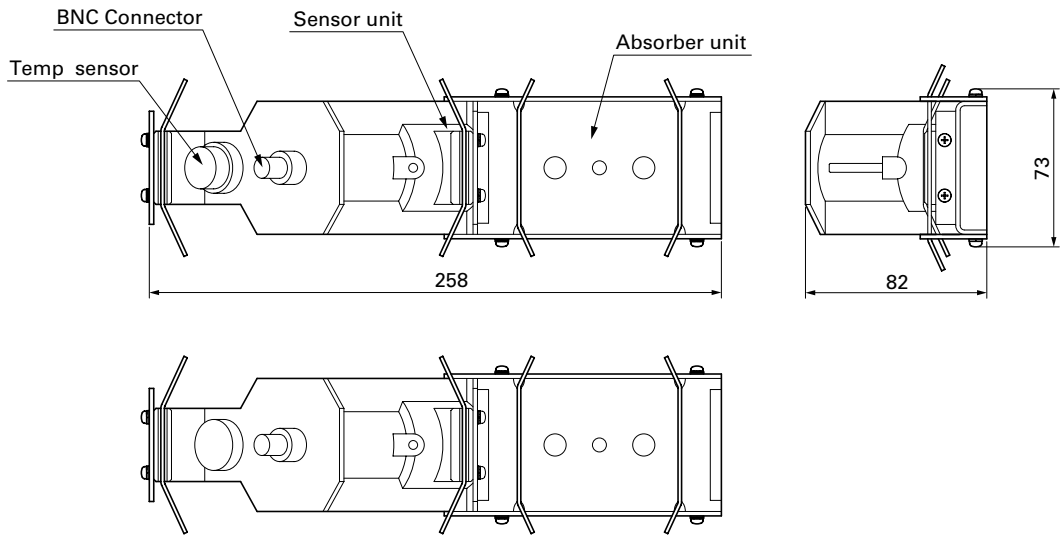

<Signal cable (type: FLY6)>

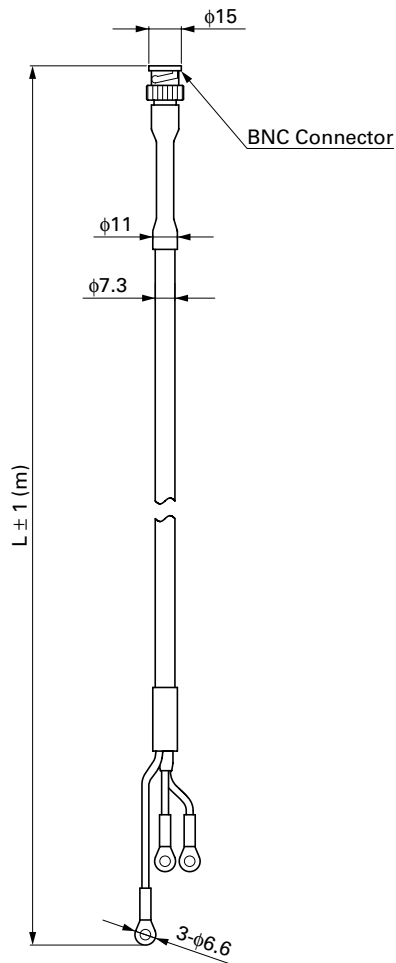

<Signal cable (type: FLY7)>

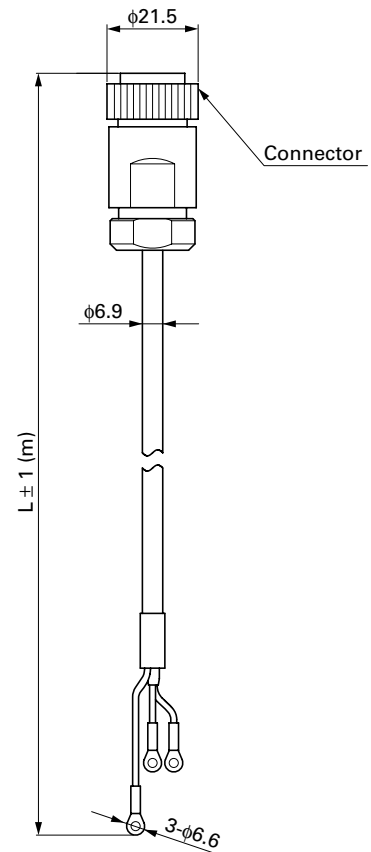

L: According to the designation of the 5th, 6th, and the 7th digits of the Code Symbols.

<Loader cable: ZZP\*TK4H6253>

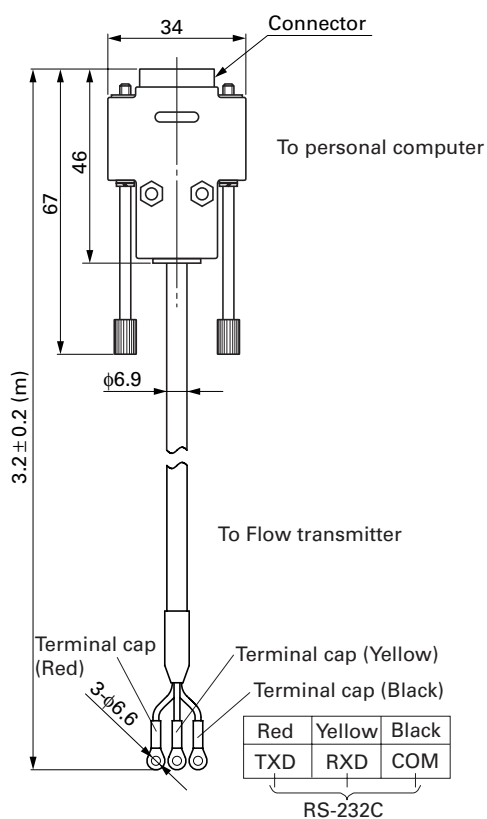

**SCOPE OF DELIVERY**

- Flow transmitter (Type: FSH):  
Flow transmitter  
CD-ROM (Instruction manual, Loader software)
- Detector (Type: FSW):  
Sensor unit  
Mounting belt  
Silicon compound (option)
- Signal cable (Type: FLY6): Cable (2 wires)
- Signal cable (Type: FLY7): Cable for temperature sensor (1)

**ITEMS DESIGNATED ORDERING**

- Flow transmitter code symbols
- Detector code symbols
- Signal cable code symbols

<Parameter specification table>

No.	Setting item	Settable range	Initial value	Settable value
1	Outer diameter	10.00 to 6200.00mm (0.393 to 244.100 inch)	60.00mm (2.362 inch)	[mm, inch]
2	Pipe material	12 menus  Pipe S.V. : 1000 to 3700m/s (3280 to 12140 ft/s)	PVC	Carbon steel, Stainless steel, PVC, Copper, Castiron, Aluminum, FRP, Ductileiron, PEEK, PVDF, Acrylic Others (Sound velocity : [m/s, ft/s])
3	Wall thickness	0.10 to 100.00mm (0.003 to 3.940 inch)	4.00mm (0.157 inch)	[mm, inch]
4	Lining material	8 menus  Lining S.V. : 1000 to 3700m/s (3280 to 12140 ft/s)	No lining	No lining, Tar epoxy, Mortar, Rubber, Teflon, Pyrex glass, PVC, Others (Sound velocity : [m/s, ft/s])
5	Lining thickness	0.01 to 100.00mm (0.000 to 3.940 inch)	—	[mm, inch]
6	Kind of Fluid	17 menus  Fluid S.V. : 500 to 2500m/s (1641 to 8203 ft/s) Kinematic viscosity : 0.001 to 999.9999 x 10 <sup>-6</sup> m <sup>2</sup> /s (0.0107 to 10763.9088 x 10 <sup>-6</sup> ft <sup>2</sup> /s)	Water	Water, Seawater, DIST. water, Ammonia, Alcohol, Benzene, Bromide, Ethanol, Glycol, Kerosene, Milk, Methanol, Toluol, Lube oil, Fuel oil, Petrol, Others (Sound velocity : [m/s, ft/s]) (Kinematic viscosity [x10 <sup>-6</sup> m <sup>2</sup> /s, ft <sup>2</sup> /s])
7	Range unit	19 menus	m/s (ft/s)	m/s, L/s, L/min, L/h, L/d, kL/d, ML/d, m <sup>3</sup> /s, m <sup>3</sup> /min, m <sup>3</sup> /h, m <sup>3</sup> /d, km <sup>3</sup> /d, Mm <sup>3</sup> /d, BBL/s, BBL/min, BBL/h, BBL/d, KBBL/d, MBBL/d, (ft/s, ft <sup>3</sup> /s, ft <sup>3</sup> /min, ft <sup>3</sup> /h, ft <sup>3</sup> /d, kft <sup>3</sup> /d, Mft <sup>3</sup> /d, gal/s, gal/min, gal/h, gal/d, kgal/d, Mgal/d, BBL/s, BBL/min, BBL/h, BBL/d, kBBL/d, MBBL/d)
8	Range type	4 menus	Single	Single, Auto 2, Bi-dir, Bi-dir Auto 2
9	Full scale or Full scale 1	In terms of flow velocity 0.00 ... 0.30 to 32.00m/s (0.98 to 104.98 ft/s)	2.00m/s (6.56 ft/s)	[ ]
10	Full scale 2	In terms of flow velocity 0.00 ... 0.30 to 32.00m/s (0.98 to 104.98 ft/s)	4.00m/s (13.12 ft/s)	[ ]
11	Range HYS.	0.00 to 20.0%	10.00%	%
12	Output limit LO.	-20 to 0%	-20%	%
13	Output limit HI.	100 to 120%	120%	%
14	Output burnout	5 menus	Hold	Not use, Hold, Upper, Lower, Zero
15	Burnout timer	0 to 900sec	10sec	sec
16	Rate limit	0.00 to 5.00m/s (0.00 to 16.40 ft/s) in terms of flow velocity	0.00m/s (0.00 ft/s)	[ ]
17	Rate limit timer	0 to 900sec	0sec	sec
18	Damping	0.0 to 100.0sec	5.0sec	sec
19	1 : Display kind	7 menus	Flowrate (m <sup>3</sup> /s)	Flow velocity, Flowrate, Total forward, Total reverse, F : Total pulse, R : Total pulse, Flow rate (%)
20	2 : Display kind	7 menus	Flow velocity (m/s)	Flow velocity, Flowrate, Total forward, Total reverse, F : Total pulse, R : Total pulse, Flow rate (%)
21	Low flow cut	0.00 to 5.00m/s (0.00 to 16.40 ft/s) in terms of flow velocity	0.01m/s (0.03 ft/s)	[ ]

No.	Setting item	Settable range	Initial value	Settable value
22	Total mode	3 menus	Total stop	Total stop, Total run, Total reset
23	Total unit	8 menus	mL	mL, L, m <sup>3</sup> , km <sup>3</sup> , Mm <sup>3</sup> , mBBL, BBL, kBBL, ft <sup>3</sup> , kft <sup>3</sup> , Mft <sup>3</sup> , kgal, gal, mBBL, BBL, kBBL, ACRF
24	Total rate	0.000 to 999999.999	0.000	[            ]
25	F : Total preset	0.000 to 999999999.999	0.000	[            ]
26	F : Total SW	0.000 to 999999999.999	0.000	[            ]
27	R : Total preset	0.000 to 999999999.999	0.000	[            ]
28	R : Total SW	0.000 to 999999999.999	0.000	[            ]
29	Output burnout	2 menus	Hold	Not use, Hold
30	Burnout timer	0 to 900sec	10sec	sec
31	Pulse width 1	3 menus	50ms	50, 100, 200
32	Pulse width 2	9 menus	50ms	0.5, 1.0, 2.0, 5.0, 10.0, 20.0, 50.0, 100.0, 200.0
33	Flow sw high	In terms of flow velocity 0.00 to 32.00m/s (0.00 to 104.98 ft/s)	0.00m/s	[            ]
34	Flow sw low	In terms of flow velocity 0.00 to 32.00m/s (0.00 to 104.98 ft/s)	4.00m/s	[            ]
35	Flow sw HYS.	0 to 20%	10%	%
36	Output DO1	15 menus	Not use	Not use, Signal error, F : Total pulse, R : Total pulse, F : Total alarm, R : Total alarm, F : Total overflow, R : Total overflow, Flow SW high, Flow SW Low, Full scale2, AO range over, Pulse range over, R : Flow direction, Device error
37	Mode DO1	2 menus	Normal	Normal, Reverse
38	Output DO2	15 menus	Not use	Not use, Signal error, F : Total pulse, R : Total pulse, F : Total alarm, R : Total alarm, F : Total overflow, R : Total overflow, Flow SW high, Flow SW Low, Full scale2, AO range over, Pulse range over, R : Flow direction, Device error
39	Mode DO2	2 menus	Normal	Normal, Reverse
40	Output DO3	15 menus	Not use	Not use, Signal error, F : Total pulse, R : Total pulse, F : Total alarm, R : Total alarm, F : Total overflow, R : Total overflow, Flow SW high, Flow SW Low, Full scale2, AO range over, Pulse range over, R : Flow direction, Device error
41	Mode DO3	2 menus	Normal	Normal, Reverse

No.	Setting item		Settable range	Initial value	Settable value
42	System unit		2 menus	Metric	Metric, English
43	Language		5 menus	English	Japanese, English, German, French, spanish
44	System Serial com.	COM. speed	3 menus	38400BPS	9600BPS, 19200BPS, 38400BPS
45		COM. parity	3 menus	None	None, Even, Odd
46		COM. stop bit	2 menus	1 bit	1 bit, 2bits
47		Serial method	2 menus	RS232C	RS232C, RS485
48		Station No.	31 menus	1	1 to 31
49	Measurement mode	Measurement mode	2 menus	1 Path	1 Path, 2 Path
50		AO Definition	3 menus	Line 1	Average, Line 1, Line 2
51	Sensor Type		4 menus	FSW12	FSW12, FSW21, FSW40, FSW50

Note1: When total pulse output has been selected for DO1, DO2 or DO3 specify total pulse value and total pulse width so that conditions 1 and 2 shown below are satisfied.

$$\text{Condition 1 : } \frac{\text{Flow span-1} \times [\text{m}^3/\text{s}]}{\text{total pulse value} \times [\text{m}^3]} \leq \begin{cases} 1000 & [\text{In the case of DO1 and DO2}] \\ 1 & [\text{In the case of DO3}] \end{cases}$$

$$\text{Condition 2 : } \frac{\text{Flow span-1} \times [\text{m}^3/\text{s}]}{\text{total pulse value} \times [\text{m}^3]} \leq \frac{1000}{2 \times \text{total pulse width} [\text{ms}]}$$

\* In the case of 2 ranges, perform calculations using either flow span-1 or flow span-2, whichever is greater.

**⚠ Caution on Safety**

\*Before using this product, be sure to read its instruction manual in advance.

**Fuji Electric Systems Co., Ltd.**

**Sales Div. III, International Sales Group  
Global Business Group**

Gate City Ohsaki, East Tower, 11-2, Osaki 1-chome,  
Shinagawa-ku, Tokyo 141-0032, Japan

<http://www.fesys.co.jp/eng>

Phone: 81-3-5435-7280, 7281 Fax: 81-3-5435-7425

<http://www.fic-net.jp/eng>