

**DIFFERENTIAL PRESSURE DEVICE**

**ORIFICE PLATE WITH CARRIER RINGS**

**DATA SHEET**

**FVA**

This orifice plate is widely used for measuring liquid, steam, and gas in low or medium pressure, lines. Tapping of differential pressure is done by corner tap method with differential pressure tapping rings having CARRIER RINGS. One set is composed of differential pressure tapping rings, an orifice plate, and a gasket. CARRIER RINGS are installed to average the differential pressure inside the rings.



**SPECIFICATIONS**

**Type:** Corner taps

**Calculation standard:**

According to concentric edge  
JIS Z 8762-1995 (ISO 5167-1:1991)

**Nominal pipe size:** 25A to 300A

These orifice plates with CARRIER RINGS can be supplied for nominal pipe sizes up to 1000A. Type FVB orifice plate is recommended for sizes 400A and above.

**Materials of main elements:**

Ring; SS400, SF440A, SUS304, SUS316 or PVC  
Orifice plate; SUS304, SUS316 or PVC  
Differential pressure tapping pipe; STPG370, SUS304 or SUS316  
Differential pressure outlet flange; SS400, SF440A, SUS304 or SUS316

**Gasket:** Valqua (Refer to table 1)

**Mount direction:** Horizontal

Vertical (Down to up)  
Vertical (Up to down)

Please specify in the specification sheet.

**Connection method:**

Connection flange;  
JIS 5, 10, 20, 30K  
ANSI 150, 300, 400Lb

Use single-part orifice plate (type FVE) for flange standard of JIS 40K, ANSI 600Lb or higher.

**Operating conditions:**

Max. pressure; 3Mpa {30.59kgf/cm<sup>2</sup>} or less  
Temperature range; -10 to 300°C  
(depends on the kind of fluid)

**Differential pressure outlet size:**

R1/2  
JIS 15A welded type  
Flange standard; JIS 5K 15A RF  
JIS 10K 15A RF  
JIS 20K 15A RF  
JIS 30K 15A RF

<Table 1 >

Type	Application	Rating (about)
No. 6500AC (Non-asbestos)	General use	3MPa, 100°C
No. 7020 (Teflon)	For no oil treatment	1.5MPa, 200°C
No. GF300 (Graphite compound)	For high temp. high press. *	3MPa, 230°C
No. 6590T (Pure graphite)	For high temp. high press. *	20MPa, 400°C

\*Non-standard



# OUTLINE DIAGRAM (Unit: mm)

## Horizontal mount.

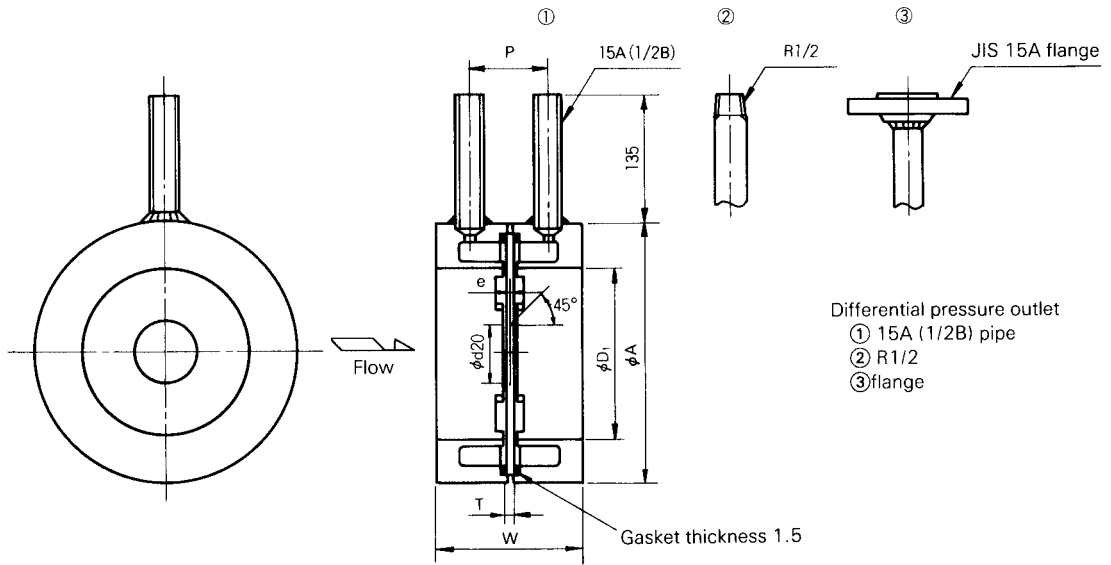

Differential pressure outlet

- ① 15A (1/2B) pipe
- ② R1/2
- ③ flange

- Notes\*:
- (1)  $\phi d20$  is orifice diameter at 20°C. (refer to orifice calculation sheet for details.)
  - (2)  $\phi D1$  is inside diameter of ring.
  - (3) Piping with nominal size of more than 250A is not chamfered.
  - (4) When differential pressure outlet is flange type, it is necessary to make piping so that outlets are not in same direction.

## Vertical mount.

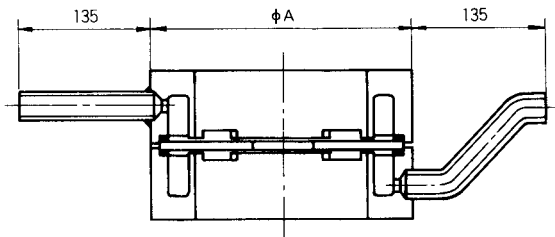

Nominal pipe diameter (A)	$\phi A$				e	W	T	P
	5K	10K	20K	30K				
25	63	71	71	76	0.2~0.4	65	2	33
32	75	81	81	86	0.3~0.5	65	2	33
40	80	86	86	97	0.3~0.5	65	2	33
50	90	101	101	111	0.5~0.8	65	2	33
65	115	121	121	137	0.5~0.8	66	3	34
80	126	131	137	147	0.5~0.8	66	3	34
90	136	141	147	160	0.5~0.8	66	3	34
100	146	156	162	170	0.8~1.2	66	3	34
125	181	187	200	205	0.8~1.2	66	3	34
150	211	217	235	248	0.8~1.2	66	3	34
200	257	267	280	293	1.5~2.0	67	4	35
250	322	330	353	357	4	67	4	35
300	367	375	403	417	4	67	4	35

## ORDERING INFORMATION

1. Code symbols
2. Kind, composition and density of fluid
3. Temperature, pressure, relative humidity and viscosity (heat insulation index for gas) of fluid
4. Flow rate (maximum, normal, minimum)
5. Instrument scale
6. Inside diameter (measured value) and material of piping
7. Type and maximum differential pressure (for existing instrument) of transmitter to be connected
8. Size of pipe flange for insertion of orifice
9. Permanent pressure loss and other restricted items

(When ordering, please specify the above items in the specification sheet.)

⚠ Caution on Safety

\*Before using this product, be sure to read its instruction manual in advance.

---

### **Fuji Electric Systems Co., Ltd.**

**Sales Div. III, International Sales Group**  
**Global Business Group**

Gate City Ohsaki, East Tower, 11-2, Osaki 1-chome,  
Shinagawa-ku, Tokyo 141-0032, Japan

<http://www.fesys.co.jp/eng>

Phone: 81-3-5435-7280, 7281 Fax: 81-3-5435-7425

<http://www.fic-net.jp/eng>