

INTEGRAL TYPE ELECTROMAGNETIC FLOWMETER

DATA SHEET

FMA1, 2

The electromagnetic flowmeter is an instrument to measure the volumetric flow rate of liquid simply by applying a magnetic field from the outside utilizing the fact that an electric conductor which crosses a magnetic field at a certain velocity causes voltage to be induced in proportion to the velocity, which is known as Faraday's law.

This flowmeter is designed with the latest electronics technology and magnetic/electric field analyzing technology, realizing a compact and light-weight structure and measurement with high accuracy.

FEATURES

1. High accuracy
The adoption of the optimum magnetic field design using the 3-dimensional finite element method has minimized the effects of flow velocity profile and materials of adjacent piping. At flow velocity of more than 1m/sFS, the measurement accuracy is as high as $\pm 0.5\%$ of indicated value when the flow is above 20%FS.
2. Wide range
Measurement range: 0 to 0.1 ... 15m/sec in flow velocity
3. High-reliability structure
The converter case is a sealed 2-chamber structure, practically free from dew condensation and sudden submergence. The adoption of stainless housing assures excellent anti-environment efficiency.
4. Easy-to-see display
LCD with back-light allows easy check of display even in a dark place. Instantaneous flow and integral volumetric flow are displayed at the same time.
5. Free power supply
The flowmeter operates on power supply 100 to 240V AC, 50/60 Hz, eliminating the need for selection of power voltage.
6. Application of international standards
The overall length of flange type flowmeter conforms with ISO draft standards. (Meter size : 6A-200A)

SPECIFICATIONS

Sensor

- Measurement item :
General-use industrial water, tap-water, sewage, waste water, chemicals slurry, and other liquids with conductivity of more than $3\mu\text{s/cm}$.
- Structure : Wafer type or flange type



- Mounting method :
Mounted via flange insertion type on opposite (wafer type) (with Guide rings)
... 2.5 to 200A
Note 1) Guide ring : A ring-shaped guide used for centering the sensor when a wafer type is mounted on the piping. or flange mounting
... 6 to 300A
Note 2) Flange with meter size 2.5A or 6A can be used for 15A.
- Liquid pressure :
-100 to 2000kPa or flange operating
- Meter size and measurement range
Measuring range is equivalent to flow velocity 0.1 to 15m/s.

Meter size	Min.measurement range [m ³ /h]	Max. measurement range [m ³ /h]
2.5A Note 3)	0 to 0.00177	0 to 0.265
6A	0 to 0.0102	0 to 1.52
15A	0 to 0.0637	0 to 9.54
25A	0 to 0.177	0 to 26.5
40A	0 to 0.453	0 to 67.8
50A	0 to 0.707	0 to 106
80A	0 to 1.81	0 to 271
100A	0 to 2.83	0 to 424
150A	0 to 6.37	0 to 954
200A	0 to 11.3	0 to 1696
250A	0 to 17.7	0 to 2650
300A	0 to 25.5	0 to 3817

Note) Meter size 2.5A: Wafer type only

• Liquid temperature :

- 10 to +120°C (Tefron lining)
- 10 to +50°C (Polyurethane lining)

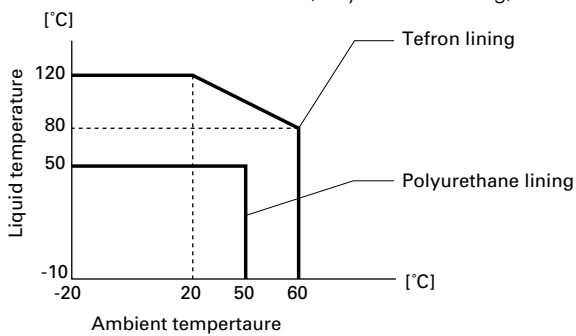

Ambient temperature-liquid temperature allowable range

• Material :

Parts in contact with Liquid (Note 1)	Lining	Tefron(PFA, TFE)	Polyurethane
	Electrode	SUS316L Hasteroy C Titanium Tantalum Platinum iridium	SUS316L
Earth ring	SUS316 Hasteroy C Titanium Tantalum	SUS316	SUS316
Housing case	SUS304		
Flange (Note 2)	SUS304 or carbon steel		

Note 1) Materials of parts in contact with liquid should be selected in consideration of erosion due to measuring liquid. Refer to the table of material selection on the attached sheet.

Note 2) Flange type only
 SUS304: Unpainting
 Carbon steel: Polyurethane corrosion-resistant painting (Silver)

Converter

• Exciting system :

Square low-frequency exciting

• Input/output signal :

Current output; 4 to 20mA DC
 Load resistance 0 to 1KΩ
 Pulse output; open-collector
 Capacity; DC30V, 0.2A or less
 ON voltage; 0.6V or less
 0.0001 to 1000P/s
 Status output; open-collector
 Capacity: DC30V, 0.2A or less
 ON voltage; 2V or less
 Status input; no-voltage contact
 Note) Status signal input or output, either one, can be

• Pulse output : Integrated pulses are outputted by setting integral constant. Pulse width 0.5 to 80ms

• Span setting : Flow FS can be set by setting flow unit and flow value. Flow velocity can also be set. Display cubic volume, length; m³, L, mL, m
 Display time unit ; /d, /h, /min, /s

• Multi-range : Automatic 2-range selection in 2-range select mode. External 2-range selection with status input is possible.

• Flow direction change : Flow direction can be reversed in flow direction mode.

• Flow display : Real time flow display, % display or user unit display is possible in 7 codes, max.

• Integration display :

Integrated volumetric flow can be displayed by setting the unit of cubic volume. Displayed cubic volume; m³, L, mL

• Fault diagnosis function :

Various faults can be diagnosed by hardware check and process check.

• Zero point adjustment :

Zero point is automatically calibrated with one-push operation.

• Output low cut :

0 to 10% FS
 Momentary output can be cut to 0% at flow rate below the set cutoff point.

• Integration low cut :

0 to 10% FS
 Integration of display and output are prevented at flow rate below the set cutoff point.

• 0% signal lock :

Display and output can be locked to 0% with status input.

• Slurry noise cut :

0 to 10% FS, 0 to 60 sec
 Slurry noise (spike noise) can be cut by setting rate limit.

• Empty detection :

Absence of liquid is detected and status signal is outputted.

• Flow switch :

-10 to 110% FS
 Status signal is outputted by setting high/low limit flow.

• Dumping time constant :

1 to 200 sec

• Converter case :

Aluminum alloy

• Arrester :

Built-in power supply arrester and current output arrester

• Wiring connection port :

G¹/₂, NPT¹/₂, Pg 13,5, M20 x 1,5

• Painting :

Body case; Polyurethane corrosion-resistant painting (Silver)
 Body cover; Polyurethane corrosion-resistant painting (Blue)

• Structure :

JIS C 0920 immersion-proof (IP67)

• Grounding :

D-class grounding (100Ω or less)

OTHER SPECIFICATIONS

When replacing Fuji' s former type sensors, flanges with short pipe are available. For details, contact our office.

Standard performance

- Accuracy rating :

Meter size	2.5A to 15A	25A to 200A
FS flow velocity 1m/s or more	Flow velocity \geq 50%FS: \pm 0.5% of rate Flow velocity<50%FS: \pm 0.25% FS	Flow velocity \geq 20%FS: \pm 0.5% of rate Flow velocity<20%FS: \pm 0.1% FS
FS flow velocity 0.3m/s or more less than 1m/s	\pm 0.5% FS	Flow velocity \geq 50%FS: \pm 0.5% of rate Flow velocity<50%FS: \pm 0.25% FS
FS flow velocity 0.1m/s or more less than 0.3m/s	\pm (0.075/Vs+0.25)% FS (Vs:FS Flow velocity [m/s])	Flow velocity \geq 50%FS: \pm (0.075/Vs+0.25)% of rate Flow velocity<50%FS: \pm (0.0375/Vs+0.125)% FS

- Power consumption :
12W or less
- Operating condition :
Ambient temperature;
-20 to 60°C (Tefron lining sensor)
-20 to 50°C (Urethane lining sensor)
Ambient humidity; 95% RH or less
Power voltage; 100 to 240V AC \pm 10%
Power frequency; 50/60Hz

Length of straight pipe

The length of the up-stream/down-stream straight pipe of the flowmeter should be long enough to ensure accurate measurements. See below.

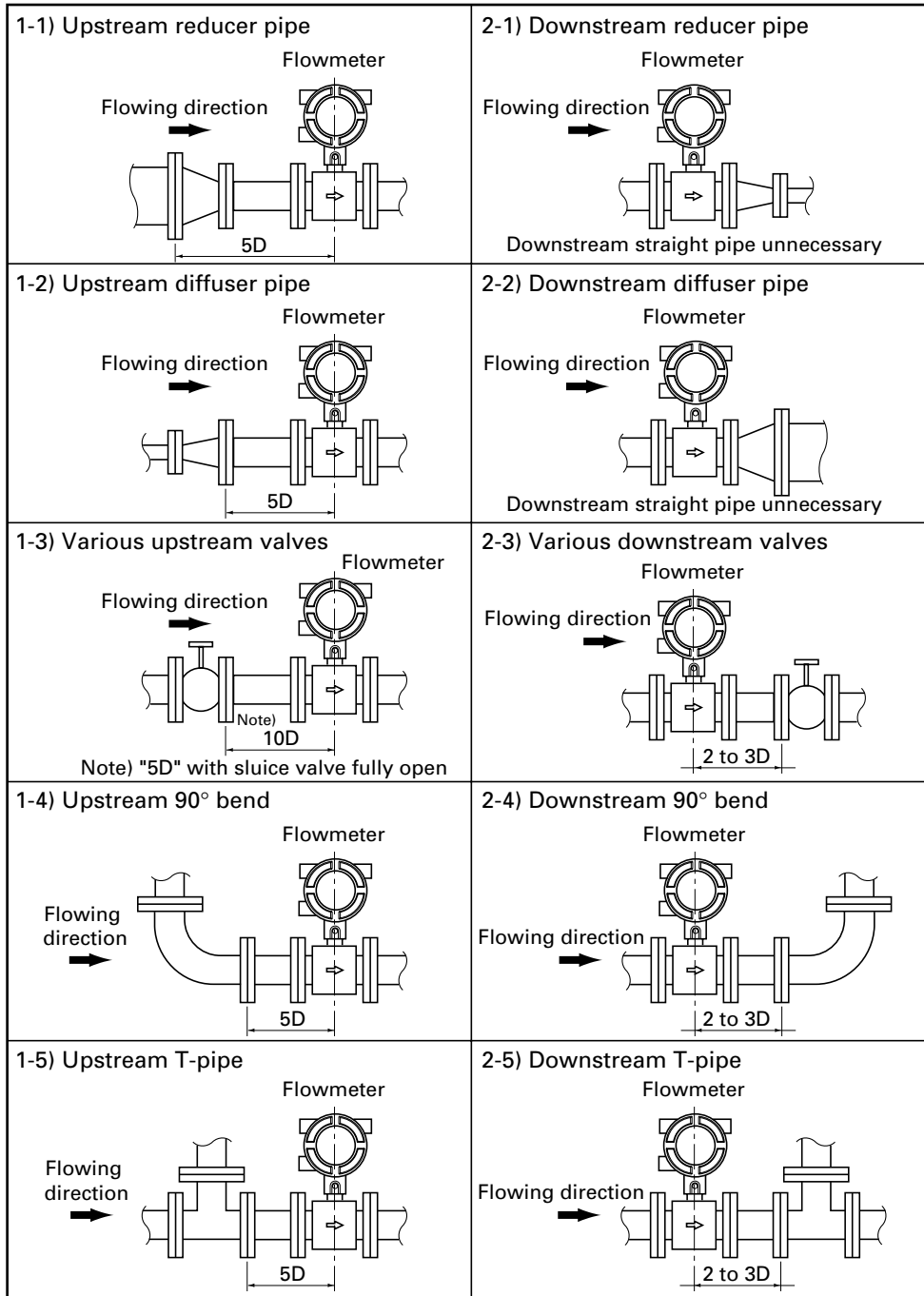

Minimum length of straight pipe between upstream/downstream joints and flowmeter.

Note 1) $L = a$ multiple of diameter D of measuring pipe.

Note 2) Do not put any objects, which affect magnetic field, electromotive force and flow profile, in the measuring pipe.

Note 3) Use a straight pipe (2D to 3D) on the downstream side, if the drift to the upstream side is affected by installing valves, etc.

Mounting posture

The flowmeter can be installed vertically, horizontally, or at other angle. When installing, be sure to observe the following points.

- ① The measuring pipe should always fill with fluid which flows in the piping.

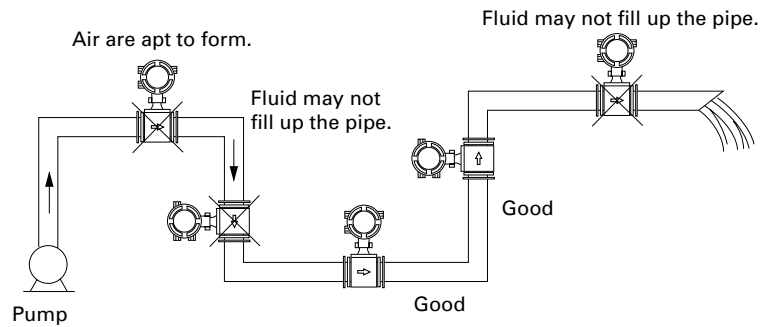

Example of mounting posture

- ② The electrode should be at a level with the ground and should always keep contact with fluid. (If the electrode is vertical to the ground air bubbles appear on the fluid and hence contaminated with deposits.)

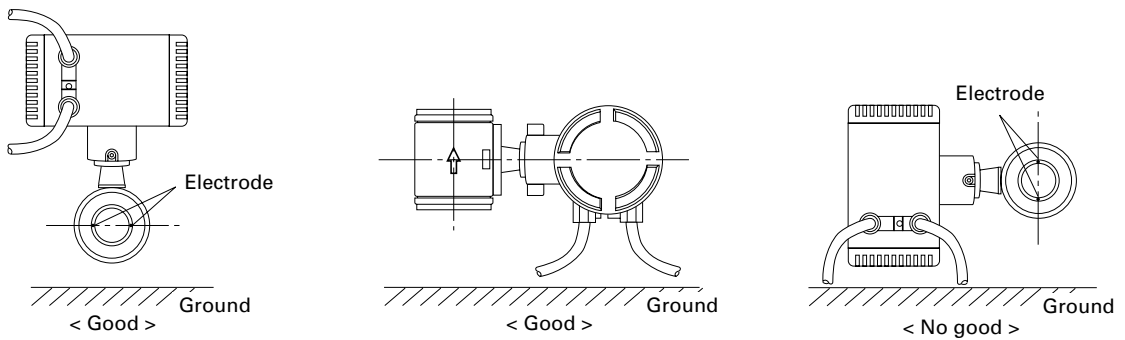

Electrode mounting position

- ③ Use of a bypass valve will provide easy zero adjustment and maintenance. Install a bypass line so that fluid flow is not interrupted. A bypass line installed as illustrated in the following figure (a) and (b) allows the inside of the pipe to be washed and cleaned without removing the flowmeter.

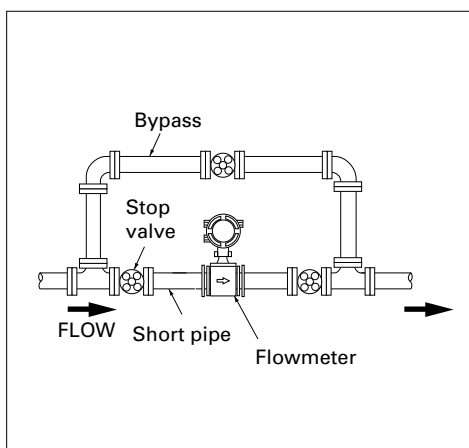

(a) Horizontal bypass line

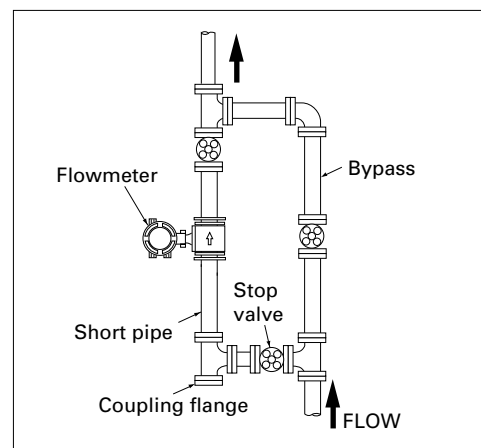

(b) Vertical bypass line

Material selection table

The following table indicates examples of recommended materials, contacting with liquid, to be used with the typical liquids measured with electromagnetic flowmeter. Evaluation of those materials has been conducted according to various documents and experience in actual use.

1. Characteristics of lining materials

[◎ : Excellent, ○ : Very good, △ : Good, × : No good]

Material	Abrasion resistance	Heat resistance	Corrosion resistance	Adhesion resistance	Remarks
Teflon PFA	×	◎	◎	◎	Ideal for the use with corrosive or adhesive fluids. Not suitable for abrasive fluid (such as slurry.) * Pay attention to permeability of TFE. Note that TFE is not suitable for use with high-temperature + negative pressure fluid.
Teflon TFE	×	◎	◎	◎	
Poly-urethane	○	×	×	△	Has inferior heat resistance or corrosion resistance. Best for slurry or the like with no corrosive properties.

2. Material selection table of electrode/earth ring

Material	Measurable liquid	Unmeasurable liquid
SUS316	Water and waste water, weak acid, weak alkali Example: 25% acetic acid or less, hydroiodic acid, butyric acid, aqueous ammonia or alike	Inorganic acid, organic acid, chloride or alike
Hastelloy C-276 or equivalent	Suitable for intermediate oxidation and reduction and can be used for various fields. Example: Sea water, formic acid, acetic acid, aqueous ammonia, normal-temperature (lower than 40°C) nitric acid, hydrochloric acid and sulfuric acid or alike	Chloride, high-temperature strong acids (nitric acid, hydrochloric acid, sulfuric acid), high temperature (higher than 40°C) or high concentration (more than 40%) ferric chloride or alike
Titanium	Resistant to sea water, most oxidative acids, chloride, sulfide and alkali. Example: Sea water, saline water, aqueous ammonia, chlorine water, polyelectrolyte, acetic acid, ferric chloride or alike	Reductive acids such as hydrochloric acid, sulfuric acid, phosphoric acid, oxalic acid
Tantalum	Resistant to most chemicals. (particularly, strong acids) Example: Hydrochloric acid, sulfuric acid, nitric acid, aqua regia, ferric chloride, hypochlorous acid, sodium hypochlorite, PAC (Polyaluminum chloride) or alike	Sodium hydroxide, potassium hydroxide, hydrofluoric acid, fuming sulfuric acid or alike
Platinum-iridium (Pt-Ir)	Resistant to almost chemicals.	Aqua regia

CODE SYMBOLS

Integral type electromagnetic flowmeter (wafer type)

1 2 3 4 5 6 7 8 9 10 11 12 13 14														Description	
F	M	A	1				1		0						Meter size (5th code)
S	A	C	D	T	E	F	G	H	J						2.5A 6A 15A 25A 40A 50A 80A 100A 150A 200A
	P	U													Lining material (6th code) PFA mold Teflon Polyurethane rubber (7th & 9th code; W only) Note) Polyurethane rubber with less than 15A of meter size cannot be used.
	W	H	C	T											Earth ring material (7th code) SUS316 Hasteroy C Titanium Tantalum
	W	H	C	T	P										Electrode material (9th code) SUS316L Hasteroy C Titanium Tantalum Platinum iridium
									0						Flange (10th code) None
										1					Guide ring (11th code) For JIS 10K
										2					For JIS 20K
										7					For JIS 75M (Meter size of less than 50A cannot be used)
										5					For ANSI 150LB
										6					For ANSI 300LB
										8					For DIN/PN 16K
										9					For DIN/PN 40K
	Y	A	B	C	D	E									Wiring connection port size (12th code) G $\frac{1}{2}$ female screw G $\frac{1}{2}$ (PF $\frac{1}{2}$) female screw with water-proof gland G $\frac{1}{2}$ (PF $\frac{1}{2}$) female screw with union and water-proof gland NPT $\frac{1}{2}$ female screw Pg 13.5 female screw M20 \times 1.5 female screw
										1					Direction of indicator (13th code) See Fig 1 Horizontal mounting
										2					Vertical mounting
															Optional specifications (14th code) Y - None A - Stainless tag plate B - Parameter setting C - Parameter setting and stainless tag plate Note) When parameter setting function is used, specify parameters in parameter designation tables 1 and 2.

Fig 1 Direction of indicator

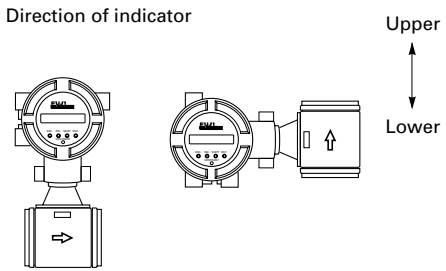

Horizontal mounting (Code 1) Vertical mounting (Code 2)

Integral type electromagnetic flowmeter (flange type)

1 2 3 4 5 6 7 8 9 10 11 12 13 14															
F	M	A	2					1							Description
A															Inside diameter (5th code) 6A Note
C															15A
D															25A
T															40A
E															50A
F															80A
G															100A
H															150A
J															200A
K															250A
L															300A
															Note) Flange size for meter size 6A is 15A or 1/2B.
P															Lining material (6th code)
T															PFA mold Tefron Note 1
U															TFE Tefron Note 2
															Polyurethane rubber Note 3
															(7th & 9th codes: W only)
															Note 1) PFA 6A to 200A
															Note 2) TFE 250A, 300A
															Note 3) Polyurethane rubber with less than 15A of meter size cannot be used.
W															Earth ring material (7th code)
H															SUS316
C															Hasteroy C
T															Titanium
															Tantalum
W															Electrode material (9th code)
H															SUS316L
C															Hasteroy C
T															Titanium
P															Tantalum
															Platinum iridium
1															Flange standard Flange material (10th code)
2															JIS 10K SUS304
4															JIS 20K SUS304
5															JIS 75M SUS304 Note 2
6															ANSI 150LB SUS304
7															ANSI 300LB SUS304
8															DIN PN16 SUS304
A															DIN PN40 SUS304 Note 1
B															JIS 10K Carbon steel
D															JIS 20K Carbon steel
E															JIS 75M Carbon steel Note 2
F															ANSI 150LB Carbon steel
G															ANSI 300LB Carbon steel
H															DIN PN16 Carbon steel
															DIN PN40 Carbon steel Note1
															Note 1) Meter size 100A or more cannot be used.
															Note 2) Meter size 50A or less cannot be used.
															Note 3) Meter size 250A or 300A can be selected only for A, B and D.
0															Guide ring (11th code)
															None
Y															Wiring connection port size (12th code)
A															G1/2 female screw
B															G1/2(PF1/2) female screw with water-proof gland
C															G1/2(PF1/2) female screw with union and water-proof gland
D															NPT1/2 female screw
E															Pg 13.5 female screw
															M20×1.5 female screw
1															Direction of indicator (13th code) See Fig.1
2															Horizontal mounting
															Vertical mounting
Y															Optional specifications (14th code)
A															None
B															Stainless tag plate
C															Parameter setting
															Parameter setting and stainless tag plate
															Note) When parameter setting function is used, specify parameters in parameter designation tables 1 and 2.

OUTLINE DIAGRAM (Unit: mm)

(Wafer type sensor)

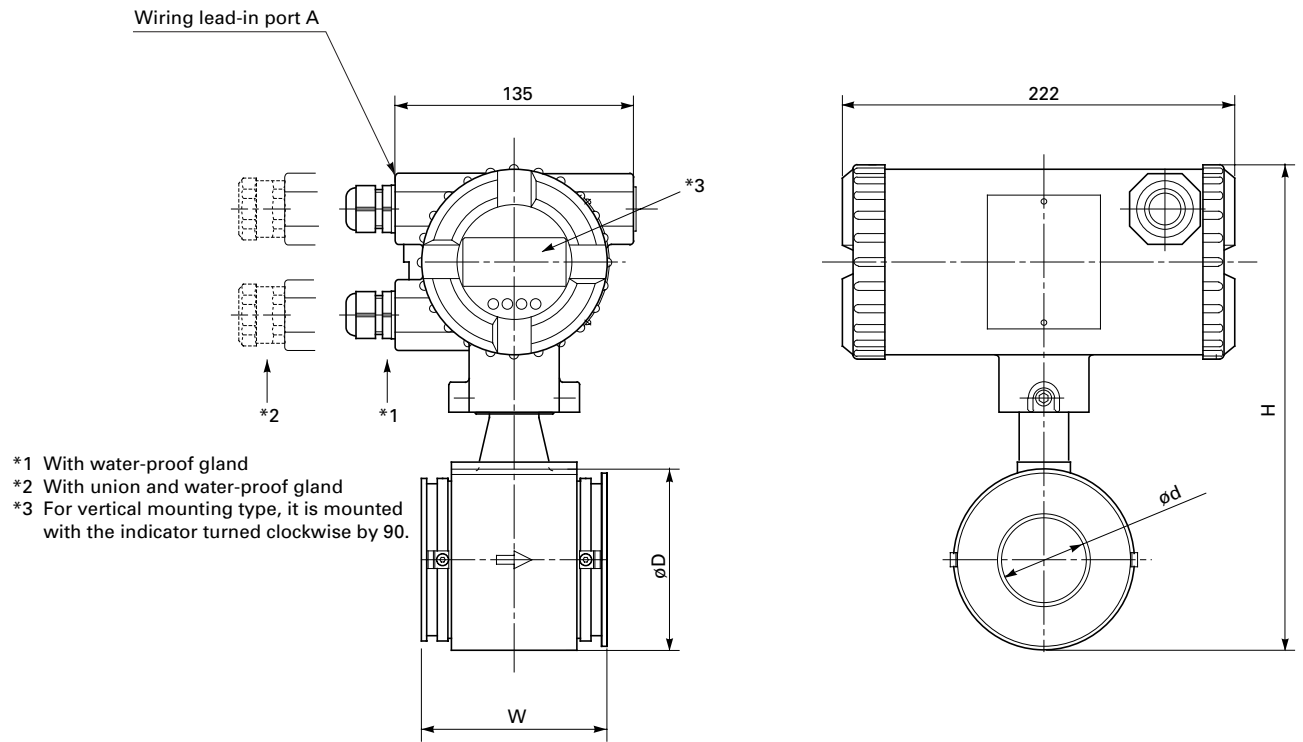

- *1 With water-proof gland
- *2 With union and water-proof gland
- *3 For vertical mounting type, it is mounted with the indicator turned clockwise by 90.

Note) When earth ring material is tantalum, W is shortened by 4mm.

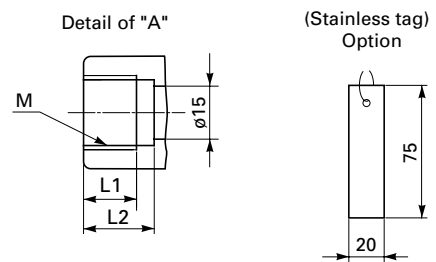

Meter size	W	ϕd	ϕD	H	Mass (Kg)
2.5A	85	2.5	50	226	4
6A	85	6	50	226	4
15A	85	12	50	226	4
25A	93	22.6	68	244	4.5
40A	100	35.6	86	262	5.5
50A	105	47.8	96	272	6
80A	150	72.3	125	301	9.5
100A	160	97.6	160	346	12
150A	190	150	211	397	16.5
200A	205	200	271	457	26.5

M	L1	L2
G $\frac{1}{2}$	13.5	18.5
NPT $\frac{1}{2}$	16	21
Pg13.5	10.5	15
M20 \times 1.5	16	21

OUTLINE DIAGRAM (Unit: mm)

(Flange type sensor)

- *1 With water-proof gland
- *2 With union and water-proof gland
- *3 For vertical mounting type, it is mounted with the indicator turned clockwise by 90.

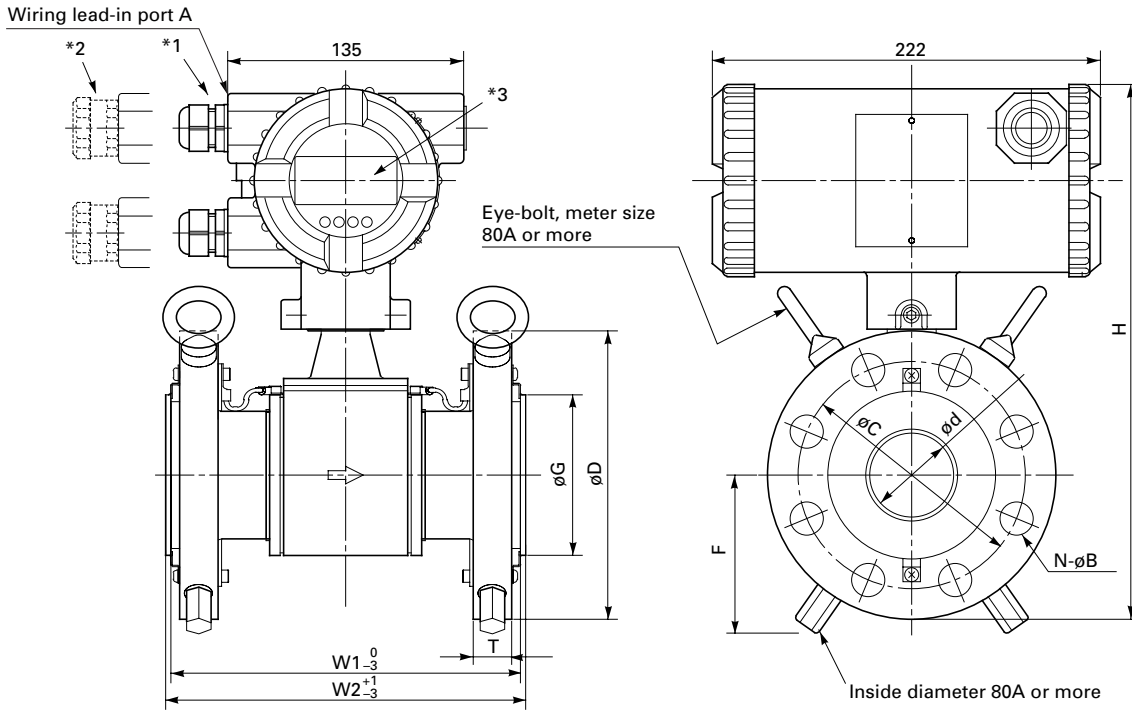

Note) When earth ring material is tantalum, W is shortened by 4mm.

Meter size	6A ^(Note1)	15A	25A	40A	50A	80A	100A	150A	200A	
W1	200	200	200	200	200	200	250	300	350	
W2	206	206	206	206	206	206	256	306	356	
JIS 10K flange	øD	95	95	125	140	155	185	210	280	330
	øC	70	70	90	105	120	150	175	240	290
	N-øB	4-15	4-15	4-19	4-19	4-19	8-19	8-19	8-23	12-23
	T	12	12	14	16	16	18	18	22	22
	øG	46	46	66	82	92	121	152	202	260
	ød	6	12	22.6	35.6	47.8	72.3	97.6	150	200
	H	248	248	272	289	301	331	371	431	486
	F	—	—	—	—	—	102	112	144	171
JIS 20K flange	øD	95	95	125	140	155	200	225	305	350
	øC	70	70	90	105	120	160	185	260	305
	N-øB	4-15	4-15	4-19	4-19	8-19	8-23	8-23	12-25	12-25
	T	14	14	16	18	18	22	24	28	30
	øG	46	46	66	82	92	121	152	202	260
	ød	6	12	22.6	35.6	47.8	72.3	97.6	150	200
	H	248	248	272	28.9	301	339	379	444	496
	F	—	—	—	—	—	108	118	160	179
JIS 75M flange	øD	—	—	—	—	—	211	238	290	342
	øC	—	—	—	—	—	168	195	247	299
	N-øB	—	—	—	—	—	4-19	4-19	6-19	8-19
	T	—	—	—	—	—	18	18	22	22
	øG	—	—	—	—	—	121	152	202	260
	ød	—	—	—	—	—	72.3	97.6	150	200
	H	—	—	—	—	—	344	385	436	492
	F	—	—	—	—	—	113	124	163	176
Mass (Kg)	—	—	—	—	—	19	23.5	36.5	54	

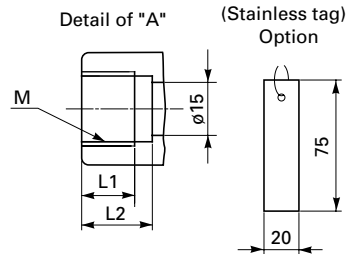

M	L1	L2
G ¹ / ₂	13.5	18.5
NPT ¹ / ₂	16	21
Pg13.5	10.5	15
M20×1.5	16	21

Note 1 : For inside diameter 6A, use flange JIS 15A.

Meter size	1/4B (Note2)	1/2B	1B	1 1/2B	2B	3B	4B	6B	8B	
W1	200	200	200	200	200	200	250	300	350	
W2	206	206	206	206	206	206	256	306	356	
ANSI 150LB flange	øD	89	89	108	127	152	191	229	279	343
	øC	60.3	60.3	79.4	98.4	120.6	152.4	190.5	241.3	298.4
	N-øB	4-16	4-16	4-16	4-16	4-20	4-20	8-20	8-23	8-23
	T	11.5	11.5	14.5	17.5	19.5	24	24	25.5	29
	øG	46	46	66	82	92	121	152	202	260
	ød	6	12	22.6	35.6	47.8	72.3	97.6	150	200
	H	245	245	264	282	300	334	380	431	493
	F	-	-	-	-	-	104	120	144	176
	Mass (Kg)	5	5	7	9	11	19	24.5	35.5	58.5
	ANSI 300LB flange	øD	95	95	124	156	165	210	254	318
øC		66.7	66.7	88.9	114.3	127	168.3	200	269.9	330.2
N-øB		4-16	4-16	4-20	4-23	8-20	8-23	8-23	12-23	12-26
T		14.5	14.5	17.5	21	22.5	29	32	37	41.5
øG		46	46	66	82	92	121	152	202	260
ød		6	12	22.6	35.6	47.8	72.3	97.6	150	200
H		248	248	272	297	306	343	393	450	512
F		-	-	-	-	-	112	130	165	193
Mass (Kg)		5.5	5.5	8	11.5	12	22	32	50.5	78.5

Note 2 : For meter size 1/4B, use flange ANSI 1/2B.

Meter size	6A (Note3)	15A	25A	40A	50A	80A	100A	150A	200A	
W1	200	200	200	200	200	200	250	300	350	
W2	206	206	206	206	206	206	256	306	356	
DIN PN16 flange	øD	95	95	115	150	165	200	220	285	340
	øC	65	65	85	110	125	160	180	240	295
	N-øB	4-14	4-14	4-14	4-18	4-18	8-18	8-18	8-22	12-22
	T	16	16	18	18	20	20	20	22	24
	øG	46	46	66	82	92	121	152	202	260
	ød	6	12	22.6	35.6	47.8	72.3	97.6	150	200
	H	248	248	267	274	306	339	376	434	472
	F	-	-	-	-	-	108	116	151	175
	Mass (Kg)	6	6	8	10.5	12	18.5	22	35	54
	DIN PN40 flange	øD	95	95	115	150	165	200	-	-
øC		65	65	85	110	125	160	-	-	-
N-øB		4-14	4-14	4-14	4-18	4-18	8-18	-	-	-
T		16	16	18	18	20	24	-	-	-
øG		46	46	66	82	92	121	-	-	-
ød		6	12	22.6	35.6	47.8	72.3	-	-	-
H		248	248	267	294	306	338	-	-	-
F		-	-	-	-	-	108	-	-	-
Mass (Kg)	6	6	7.5	10.5	12	19.5	-	-	-	

Note 3 : For meter size 6A, use flange DIN 15A.

OUTLINE DIAGRAM (Unit: mm)

- *1 With water-proof gland
- *2 With union and water-proof gland
- *3 For vertical mounting type, it is mounted with the indicator turned clockwise by 90.

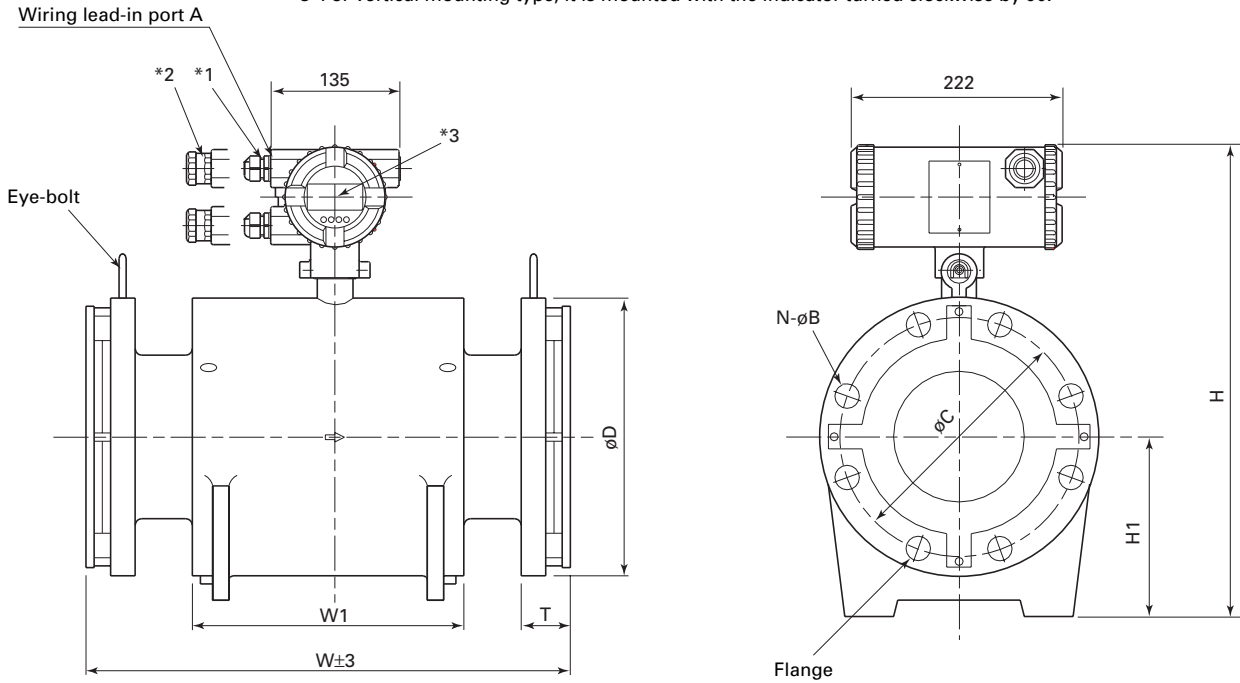

Detail of "A"

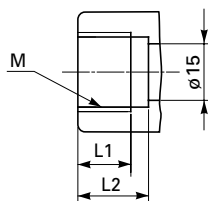

(Stainless tag)
Option

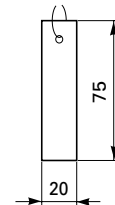

Meter size	250A	300A	
W	595	595	
W1	320	360	
H	543	598	
H1	220	250	
JIS 10K flange	ϕD	400	445
	ϕC	355	400
	N- ϕB	12-25	16-25
	T	36	38
	Mass (Kg)	97	115
JIS 20K flange	ϕD	430	480
	ϕC	380	430
	N- ϕB	12-27	16-27
	T	46	48
	Mass (Kg)	100	120
JIS 75M flange	ϕD	410	464
	ϕC	360	414
	N- ϕB	8-23	10-23
	T	36	38
Mass (Kg)	97	115	

M	L1	L2
G $1/2$	13.5	18.5
NPT $1/2$	16	21
Pg13.5	10.5	15
M20 \times 1.5	16	21

EXTERNAL CONNECTION DIAGRAM

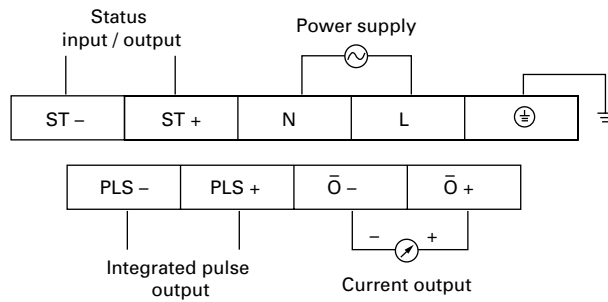

FLOW RATE-FLOW VELOCITY CONVERSION DIAGRAM

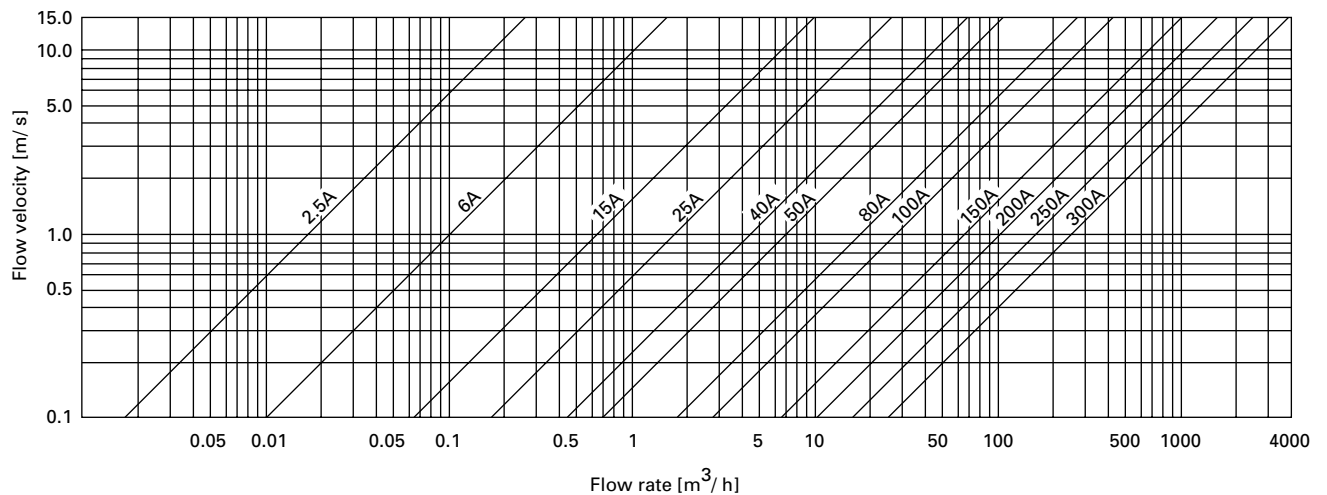

SCOPE OF DELIVERY

Main unit (mounting bolt and packing should be prepared separately)

Spare parts (spare fuse (1A), guide rings / for wafer type (Note), 1set spare water-proof gland / for water-proof gland type)

Note) Not supplied for 2.5A-25A ANSI 150LB and 100A, 200A JIS 10K.

ITEMS SPECIFIED AT ORDERING

1. Type, specification code
2. Flow measurement range and measurement fluid.
3. Stainless tag plate, and tag No. (less than 16 alphanumeric characters).
4. If you want the instrument with certain parameters factory set as you desire, submit the parameter designation tables 1 and 2 when specifying them.

If you want the instrument with certain parameters factory set as you desire, specify them in parameter designation tables 1 and 2.

Company : _____

Sector : _____

Name : _____

Telephone No. : _____

Measured fluid : _____

<Parameter designation table 1>

Put check marks into which precede items to modify for.

Setting item	Standard set value (Note 1)	Range	Item to select	Item selection or value designation	Example
Damping	3.0s	1.0 to 200.0s		___ . __ [s]	020.0s
LCD 1st line indication	Real scale indication Unit: Factory set as per range designation	<1st line, 2nd line> ① Flow velocity indication (m/s) ② Real scale Volume unit: mL, L, m ³ Time unit: /s, /min, /h, /d ③ Percent indication (%) ④ Arbitrary unit indication User factor: 0.0001 to 99999. User unit: Up to six ASCII code characters. • Must be designated for mass flow rate indication, etc. • If mass flow rate indication (*) is designated, designate the density of measured fluid instead of user factor. ⑤ Integrated real scale indication Volume unit: mL, L, m ³ ⑥ Integrated pulse indication • Separately designate the "integration constant" together.	<Designation of 1st line indication> Select an item from the following. <input type="checkbox"/> Flow velocity indication <input type="checkbox"/> Real scale indication <input type="checkbox"/> Percent indication <input type="checkbox"/> Arbitrary unit indication	According to selection of left item, designate necessary item and value. Unit: m/s fixed. Volume unit: <input type="checkbox"/> mL, <input type="checkbox"/> L, <input type="checkbox"/> m ³ Time unit: <input type="checkbox"/> s, <input type="checkbox"/> /min, <input type="checkbox"/> /h, <input type="checkbox"/> /d None. User factor: _____ Or, for mass flow rate indication, designate the density of measured fluid instead of user factor. Density of fluid: _____ User unit: _____	0.9765 t/h
			<input type="checkbox"/> Integrated real scale indication <input type="checkbox"/> Integrated pulse indication <input type="checkbox"/> Integration arbitrary unit indication	Volume unit: <input type="checkbox"/> mL, <input type="checkbox"/> L, <input type="checkbox"/> m ³ * Designate "integration constant" separately. User factor: _____ Or, for mass flow rate indication, designate the density of measured fluid instead of user factor. Density of fluid: _____ User unit: _____	0.9765 t
			<Designation of 2nd line indication> Select an item from the following. <input type="checkbox"/> Flow velocity indication <input type="checkbox"/> Real scale indication <input type="checkbox"/> Percent indication <input type="checkbox"/> Arbitrary unit indication	According to selection of left item, designate necessary item and value. Unit: m/s fixed. Volume unit: <input type="checkbox"/> mL, <input type="checkbox"/> L, <input type="checkbox"/> m ³ Time unit: <input type="checkbox"/> s, <input type="checkbox"/> /min, <input type="checkbox"/> /h, <input type="checkbox"/> /d None. User factor: _____ Or, for mass flow rate indication, designate the density of measured fluid instead of user factor. Density of fluid: _____ User unit: _____	0.9765 t/h
			<input type="checkbox"/> Integrated real scale indication <input type="checkbox"/> Integrated pulse indication <input type="checkbox"/> Integration arbitrary unit indication	Volume unit: <input type="checkbox"/> mL, <input type="checkbox"/> L, <input type="checkbox"/> m ³ * Designate "integration constant" separately. User factor: _____ Or, for mass flow rate indication, designate the density of measured fluid instead of user factor. Density of fluid: _____ User unit: _____	0.9765 t
			<input type="checkbox"/> Status I/O indication <input type="checkbox"/> NO FUNCTION	None. None.	
			⑦ Integration arbitrary unit indication User factor: 0.0001 to 99999. User unit: Up to four ASCII code characters. • Must be designated for mass flow rate indication, etc. • If mass indication (*) is designated, designate the density of measured fluid instead of user factor. ⑧ Status I/O indication Indication of function and action of status I/O selected on 2nd line of LCD (can specify 2nd line only). ⑨ NO FUNCTION Do not indicate LCD 2nd line (can specify 2nd line only). (*): Electromagnetic flow meter is a volumetric flow meter. In case of mass or mass flow rate indication, therefore, any change of density of measured fluid causes an error.	_____ Or, for mass flow rate indication, designate the density of measured fluid instead of user factor. Density of fluid: _____ User unit: _____	0.9765 t
			<input type="checkbox"/> Status I/O indication <input type="checkbox"/> NO FUNCTION	None. None.	
			① Flow velocity indication (m/s) ② Real scale Volume unit: mL, L, m ³ Time unit: /s, /min, /h, /d ③ Percent indication (%) ④ Arbitrary unit indication User factor: 0.0001 to 99999. User unit: Up to six ASCII code characters. • Must be designated for mass flow rate indication, etc. • If mass flow rate indication (*) is designated, designate the density of measured fluid instead of user factor. ⑤ Integrated real scale indication Volume unit: mL, L, m ³ ⑥ Integrated pulse indication • Separately designate the "integration constant" together.	Volume unit: <input type="checkbox"/> mL, <input type="checkbox"/> L, <input type="checkbox"/> m ³ Time unit: <input type="checkbox"/> s, <input type="checkbox"/> /min, <input type="checkbox"/> /h, <input type="checkbox"/> /d Must be designated in 4 significant digits. Value: _____	100.0
			Instantaneous output low-cut point	0.0%	0.0% to 10.0%
Current output burnout	UNDER SCALE (2.4mA)	NOT USED (hold) OVER SCALE (21.6mA) UNDER SCALE (2.4mA)	<input type="checkbox"/> NOT USED <input type="checkbox"/> OVER SCALE <input type="checkbox"/> UNDER SCALE	None.	
Integration direction	FORWARD	FORWARD REVERSE	<input type="checkbox"/> FORWARD <input type="checkbox"/> REVERSE	None.	
Integration constant (Note 2) (integration value per pulse)	0m3	Value: 0.000000000 to 999999999. Unit : mL, L, m ³	Volume unit: <input type="checkbox"/> mL, <input type="checkbox"/> L, <input type="checkbox"/> m ³	Value: _____	
Integrated pulse width (Note 3)	30ms	0.5 to 80ms	None.	___ . __ [ms]	50.0[ms]
Integration preset value	0m3	Value: -999999999 to +999999999 Unit : Linked with unit of integration constant.	None.	_____	100000

(Note 1) Standard set value refers to parameter set value as factory set in case parameter setting is not designated.

(Note 2) Designate so that 0.0001 to 1000 pulses integrated will be output per second (so that following expression will hold) when flow rate is maximum.

$$0.0001 \leq \text{range [m}^3/\text{h]} / (\text{integration constant [m}^3] \times 3600) \leq 1000$$

(Note 3) Designate the integrated pulse width so as to hold: (Integration constant [m³]) × 3600 / range [m³/h] ≥ integrated pulse width [ms] / 500

<Parameter designation table 2>

Setting item	Standard set value (Note 1)	Range	Item to select	Item selection or value designation	Example
Integration low-cut point	3.0%	0.0 to 10.0%	None	__ . __ [%]	5.0%
Integration burnout	HOLD	HOLD COUNT	<input type="checkbox"/> HOLD <input type="checkbox"/> COUNT	None	
Status function	NO FUNCTION		Select one of functions below.	According to selection on the left, designate item and value.	
		① NO FUNCTION	<input type="checkbox"/> NO FUNCTION	None	
		② External 2 range changeover • 2nd range: 0.1 to 15 m/s converted to flow velocity. • Status input: INPUT CLOSED (Note 4) INPUT OPEN	<input type="checkbox"/> External 2 range changeover	Must be designated in 4 significant digits. 2nd range: __ . __ . __ . __ Volume unit: <input type="checkbox"/> mL, <input type="checkbox"/> L, <input type="checkbox"/> m ³ Time unit: <input type="checkbox"/> /s, <input type="checkbox"/> /min, <input type="checkbox"/> /h, <input type="checkbox"/> /d <input type="checkbox"/> INPUT CLOSED <input type="checkbox"/> INPUT OPEN	10.00
		③ External forward/reverse range changeover • 2nd range: 0.1 to 15 m/s converted to flow velocity. • Status input: INPUT CLOSED (Note 4) INPUT OPEN	<input type="checkbox"/> External forward/reverse range changeover	Must be designated in 4 significant digits. 2nd range: __ . __ . __ . __ Volume unit: <input type="checkbox"/> mL, <input type="checkbox"/> L, <input type="checkbox"/> m ³ Time unit: <input type="checkbox"/> /s, <input type="checkbox"/> /min, <input type="checkbox"/> /h, <input type="checkbox"/> /d <input type="checkbox"/> INPUT CLOSED <input type="checkbox"/> INPUT OPEN	10.00
		④ 0% signal lock • Status input: INPUT CLOSED (Note 4) INPUT OPEN	<input type="checkbox"/> 0% signal lock	<input type="checkbox"/> INPUT CLOSED <input type="checkbox"/> INPUT OPEN	
		⑤ External zero adjustment • Status input: INPUT CLOSED (Note 4) INPUT OPEN	<input type="checkbox"/> External zero adjustment	<input type="checkbox"/> INPUT CLOSED <input type="checkbox"/> INPUT OPEN	
		⑥ External integration preset • Status input: INPUT CLOSED (Note 4) INPUT OPEN * Designate preset value separately in item of "integration preset value".	<input type="checkbox"/> External integration preset	<input type="checkbox"/> INPUT CLOSED <input type="checkbox"/> INPUT OPEN	
		⑦ Automatic 2 range changeover • 2nd range: 0.1 to 15 m/s converted to flow velocity. • Changeover hysteresis: 0.0 to 20.0% (with respect to smaller range). • Status output: OUTPUT ON (Note 5) OUTPUT OFF	<input type="checkbox"/> Automatic 2 range changeover	Must be designated in 4 significant digits. 2nd range: __ . __ . __ . __ Volume unit: <input type="checkbox"/> mL, <input type="checkbox"/> L, <input type="checkbox"/> m ³ Time unit: <input type="checkbox"/> /s, <input type="checkbox"/> /min, <input type="checkbox"/> /h, <input type="checkbox"/> /d Hysteresis: __ . __ % <input type="checkbox"/> OUTPUT ON <input type="checkbox"/> OUTPUT OFF	10.00 5.0%
		⑧ Automatic forward/reverse changeover • 2nd range: 0.1 to 15 m/s converted to flow velocity. • Changeover hysteresis: 0.0 to 10.0% (with respect to smaller range). • Status output: OUTPUT ON (Note 5) OUTPUT OFF	<input type="checkbox"/> Automatic forward/reverse changeover	Must be designated in 4 significant digits. 2nd range: __ . __ . __ . __ Volume unit: <input type="checkbox"/> mL, <input type="checkbox"/> L, <input type="checkbox"/> m ³ Time unit: <input type="checkbox"/> /s, <input type="checkbox"/> /min, <input type="checkbox"/> /h, <input type="checkbox"/> /d Hysteresis: __ . __ % <input type="checkbox"/> OUTPUT ON <input type="checkbox"/> OUTPUT OFF	10.00 5.0%
		⑨ Flow switch • Upper limit: -10.0 to 110.1% (if 110.1% is selected, upper limit is invalid). • Lower limit: -10.1 to 110.0% (if -10.1% is selected, lower limit is invalid). • Status output: OUTPUT ON (Note 5) OUTPUT OFF	<input type="checkbox"/> Flow switch	Upper limit: __ . __ . __ . __ [%] Lower limit: __ . __ . __ . __ [%] <input type="checkbox"/> OUTPUT ON <input type="checkbox"/> OUTPUT OFF	+90.0[%] -02.0[%]
		⑩ Integration switch • Set value: -999999999 to +999999999 • Status output: OUTPUT ON (Note 5) OUTPUT OFF * Unit is the same as set value for integration constant.	<input type="checkbox"/> Integration switch	Set value: ____ . ____ . ____ . ____ <input type="checkbox"/> OUTPUT ON <input type="checkbox"/> OUTPUT OFF	
⑪ Alarm output • Alarm selection ALL FUNCTION, HARDWARE FAULT, PROCESS FAULT • Status output: OUTPUT ON (Note 5) OUTPUT OFF	<input type="checkbox"/> Alarm output	• Alarm selection <input type="checkbox"/> ALL FUNCTION <input type="checkbox"/> HARDWARE FAULT <input type="checkbox"/> PROCESS FAULT • Status output: <input type="checkbox"/> OUTPUT ON <input type="checkbox"/> OUTPUT OFF			
Empty detection function	INHIBIT	INHIBIT ENABLE	<input type="checkbox"/> INHIBIT <input type="checkbox"/> ENABLE	None	
TAG-NO	Blank unless designated	Up to 16 alphanumeric	None	____ . ____ . ____ . ____ ____ . ____ . ____ . ____	F-100
Flow direction	FORWARD	FORWARD REVERSE	<input type="checkbox"/> FORWARD <input type="checkbox"/> REVERSE	None	

(Note 4) Status input specifications: No-voltage contact. 1 kΩ or less when closed. 50 kΩ or more when open.

(Note 5) Status output specifications: Capacity; 30V DC or less, 0.2A or less, ON voltage; 2V or less

⚠ Caution on Safety

*Before using this product, be sure to read its instruction manual in advance.

Fuji Electric Systems Co., Ltd.

Head Office

Gate City Ohsaki, East Tower, 11-2, Osaki 1-chome,
Shinagawa-ku, Tokyo 141-0032, Japan

<http://www.fesys.co.jp/eng>

Instrumentation Div.

International Sales Dept.

No.1, Fuji-machi, Hino-city, Tokyo, 191-8502 Japan

Phone: 81-42-585-6201, 6202 Fax: 81-42-585-6187

<http://www.fic-net.jp/eng>

Information in this catalog is subject to change without notice.

Printed in Japan