

FC SERIES SETTER (CONTINUOUS OUTPUT TYPE)

DATA SHEET

PDF3

The FC series Setter is used for remote setting of a controller, setting of variable constants of diverse computing units, etc.

This product is a setter to be used in a process and it excels in the effect of monitoring due to adoption of a color LCD.

Besides standard signals of 1 to 5 V DC, input signals from thermocouples and resistance bulbs can be handled at option.

FEATURES

1. High visibility ensured with color graphic display

A color LCD is adopted for graphic display of multi-loop bar graph and trend screens, etc.

2. Communication function (option)

RS-485 (Modbus[®]) are available.

3. Memory card (option)

Memory card can save any data, for example process input, WAFER output, etc.

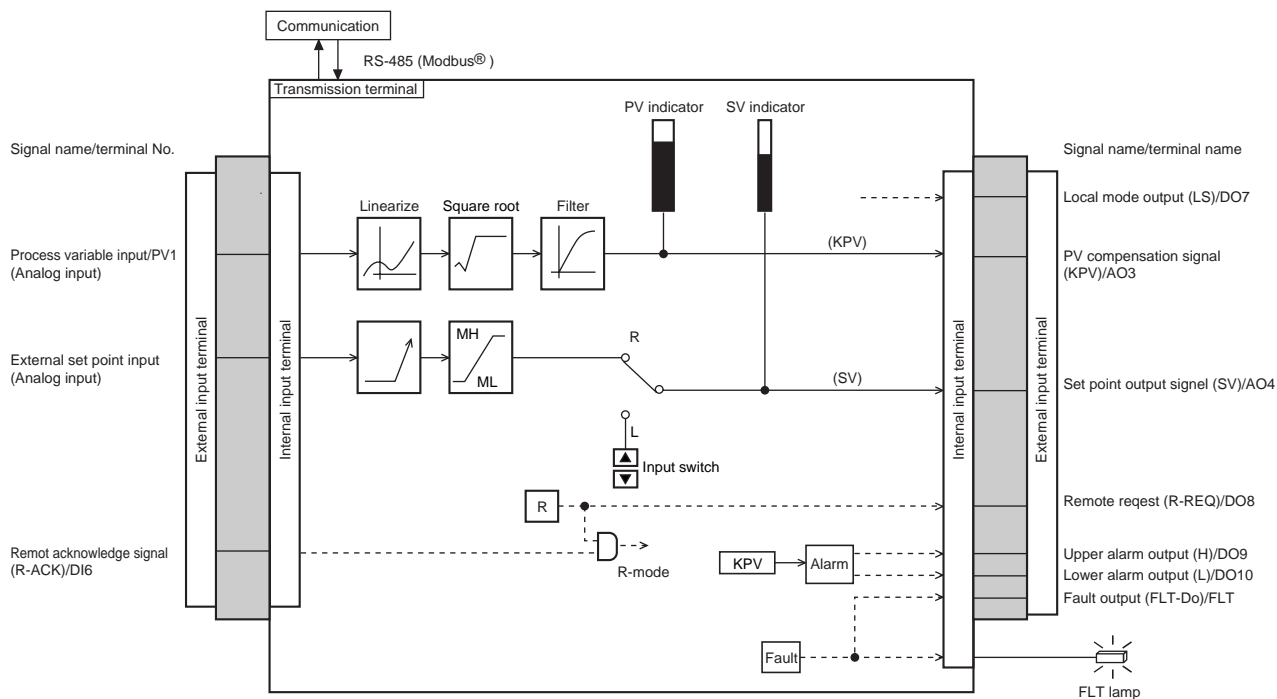

SPECIFICATIONS

1. Input Signals

Performance under reference condition ($23 \pm 2^\circ\text{C}$, $55 \pm 10\% \text{RH}$, Power voltage and frequency variation $\pm 1\%$, free from the effect of external noise) unless otherwise specified.

1-1 Analog input signal

• Number of inputs

8 inputs

• Inpute signal types

: DC voltage, thermocouple (option), resistance bulb (option)

Two thermocouple inputs or two resistance bulb inputs are selectable.

(1) DC voltage

- Input range: Selectable among 0 to 5 V DC, 1 to 5 V DC and 0 to 10 V DC
Initial set before delivery : 1 to 5 V DC
- Input accuracy: $\pm 0.1\%$ of input span ± 1 digit
- Scaling (Industrial data conversion) :
Settable within a range from -32767 to 32767
4, 3, 2, 1 or 0 digit below decimal point is selectable.
Initial set before delivery : 0.00% to 100.00%
- Industrial unit: Settable in up to 8 characters
Usable characters: Alphabets numerals, symbols such as +, -, *, etc.
- Input accuracy guarantee range: -5% to 105% of input range.
- Maximum continuous permissible voltage: $\pm 35 \text{ V}$
- Input resistance: 1 M Ω or more
- Influence by ambient temperature: $\pm 0.1\% \text{ FS}/10^\circ\text{C}$ or less.
- Influence by power supply fluctuation: $\pm 0.1\% \text{ FS}$ or less.
- Isolation : Non-isolated from internal circuit.
- In case of current input:
Shunt resistor need to be connected to the analog input terminal.
(250 Ω shunt resistor is optional item)

(2) Thermocouple (option)

- Types and measurable ranges:
* See Table 2.
- Input accuracy: $\pm 0.2\% \text{ FS} \pm 1$ digit
[Note]B type: $\pm 5\%$ between 0 to 400°C
S and R type: $\pm 1\%$ between 0 to 500°C
All type of TC: $\pm 5\%$ under -100°C
- Reference junction compensation error: $\pm 1.0^\circ\text{C}$ (provided measurable range is -50°C and higher)
[Note]Reference junction compensation resistor is connected at external input terminal in case of thermocouple input is ordered.
- Input accuracy guarantee range: -5% to 105% of input range.
- Input resistance: 1 M Ω or more

- Allowable signal source resistance:
100 Ω or less (Zener barrier connection unallowable)
- Influence by signal source resistance:
About 0.25 $\mu\text{V}/\Omega$
- Influence by ambient temperature:
 $\pm 0.2\% \text{ FS}/10^\circ\text{C} \pm 1^\circ\text{C}$ or less.
- Influence by power supply fluctuation:
 $\pm 0.2\% \text{ FS} \pm 1^\circ\text{C}$ or less
- Burnout detection: Provided
- Isolation: Isolated from internal circuit.

(3) Resistance bulb (option)

- Types and measurable ranges:
* See Table 2.
- Input accuracy: $\pm 0.2\% \text{ FS} \pm 1$ digit
- Input accuracy guarantee range:
-5% to 105% of input range
- Allowable wiring resistance: 10 Ω or less per wire, provided wiring resistance must be equal among 3 wires (Zener barrier connection unallowable)
- Influence by ambient temperature: $\pm 0.2\% \text{ FS}/10^\circ\text{C}$ or less.
- Influence by power supply fluctuation:
 $\pm 0.2\% \text{ FS}$ or less
- Burnout detection: Provided
- Isolation: Isolated from internal circuit.

[Note] FS: full span.

• Sampling period

: 100 ms

1-2 Digital input signal

• Number of inputs

: 10 inputs

• Electrical specifications

: No-voltage contact or transistor contact
ON/0 V, OFF/24 V, ON current/about 8 mA

Isolated from the internal circuit by photocoupler. Not isolated between each digital input and output.

• Contact rating : 30 V DC, 10 mA or more

• Signal judgment

: No-voltage contact
Contact resistance;
200 Ω or less at ON,
100 k Ω or more at OFF

: Transistor contact
1V max at ON.,
leakage current 100 μA max. at OFF

2. Output Signals

Performance under reference condition ($23 \pm 2^\circ\text{C}$, $55 \pm 10\% \text{RH}$, Power voltage and frequency variation $\pm 1\%$, free from the effect of external noise) unless otherwise specified.

2-1 Analog output signal

(1) Auxiliary analog output

• Number of outputs:

: 4 outputs

- Types of signal: Selectable among 0 to 5 V DC, 1 to 5 V DC and 0 to 10 V DC
Initial set before delivery: 1 to 5 V DC

- **Output accuracy**
: $\pm 0.1\%$ FS
- **Load resistance**
: 15 k Ω or more
- **Output guarantee range**
: 1 to 5 VDC : -12.5% to 112.5%
: 0 to 5 VDC : 0% to 112.5%
: 0 to 10VDC : 0% to 105%
- **Influence by power supply fluctuation**
: $\pm 0.1\%$ FS or less
- **Isolation**
: Non-isolated from internal circuit

2-2 Digital output signal

- **Number of outputs**
: 10 outputs
- **Electrical specifications**
: Transistor open collector
1 V max. at ON, 10 μ A max at OFF.
Isolated from the internal circuit by photocoupler. Not isolated between each digital input and output.
- **Output rating** : 30 V DC, 100 mA max. (resistive load)

2-3 Fault output signal (terminal symbol FLT)

- **Number of outputs**
: 1 output
- **Electrical specifications**
: Transistor open collector
1 V max. at ON, 10 μ A max at OFF.
Isolated from the internal circuit by photocoupler. Not isolated between each digital input and output.
- **Output rating** : 30 V DC, 100 mA max. (resistive load)

3. Display

- **Display unit** : 16 Colors graphic liquid crystal display, with CFL back light and contrast adjust function.
- **Contents of display**
: Menu
: Loop panel
Bar graph display, digital display, etc.
: Trend screen (max. 8 screens)
: Alarm and alarm historical screen
: Analog input/output and digital input/output indication screen
: WAFER connection screen
: Parameter setting screen

4. Setting and Operation

(1) Set point setting method

- **Setting key** : Up key/down key
- **Setting speed** : About 40 s/FS
- **Setting resolution**
: 0.05% FS/each key press

(2) Operation mode

- **Kinds of operation mode**
: R and L

[Note] R: Remote mode (operation according to external set point)

L: Local mode (operation according to the internal set point)

- **Changeover** : Balance bumpless changeover from Local to Remote
Balanceless bumpless in other changeover

[Note] Balance bumpless changeover is a method where each setting value needs to be balanced by operator himself at the time of changeover. Balanceless bumpless changeover is a method where each setting value is automatically balanced by the setter at the time of changeover.

(3) Security

- **Method** : Setting of a password
- **Password** : Settable in 4 numerals (within 0000 to ffff)
Initial set before delivery: 0000

• Contents of security

: Inhibition of parameter setting

(4) Other setting items

- **Tag name** : Settable in up to 8 characters
Usable characters; alphabets, numerals, symbols such as +, -, *, etc.

5. Power Supply

- **Voltage rating** : 100 V to 240 V AC/24 V DC
- **Allowable range**
: 85 V to 264 V AC/20 V to 30 V DC
- **Frequency** : 47 to 63 Hz
- **Power consumption**
: 60 VA or less (100 V to 240 V AC)
: 30 W or less (24 V DC)
- **Power supply output voltage (terminal symbol VP and PC)**
: 20V to 30V DC, max. 40mA

6. General performance and characteristics

- **Insulation resistance**
: 500 V DC, 50 M Ω or more.
- **Dielectric strength**
: 2,000 V AC for 1 minute between power terminal and ground terminal in case of 100 V to 240 V AC power supply
: 500 V AC for 1 minute between power terminal and ground terminal in case of 24 V DC power supply.
: 500 V AC for 1 minute between signal communication terminals and ground terminal
- **Rush current** : 60 A or less. (100 V AC to 240 V AC power supply)
- **Clock** : Set and display year, month, day, hour, minute, second
accuracy : ± 100 ppm except of time lag shorter than 1 s / power ON / OFF action.
- **Memory backup**
: Protection by lithium battery.
(expected battery life is about 2 years under room temperature)
Parameter and program are stored non-volatile memory.

7. Operating and storage conditions

- **Operating temperature**
: 0 to 50°C
: 0 to 40°C in case of multiple mounting
(Temperature change rate : Max. 10°C / h)
- **Transport and storage temperature**
: -20 to 70°C
(Temperature change rate : Max. 20°C / h)
- **Operating humidity**
: 5 to 90% RH, condensation unallowable
- **Transport and storage humidity**
: 5 to 95% RH, condensation unallowable
- **Operating continuous vibration**
: 4.9 m/s² or less
- **Transport and storage shock**
: Fall of 60cm max. in packed status

8. Power Failure and restart Function

- **Permissible duration of momentary power failure**
: 20 ms at 90V AC (100 V to 240 V AC only)
[Note] In case of 24 V DC, system power supply unit (model: PXJ) is recommended to avoid power failure problem.
- **Behavior at power failure detection**
: Control stops at detection of power failure.
- **Power recovery mode**
: Selectable initial start and continuous start

9. Self-Diagnosis

- **Control and computation circuit failure**
: Monitoring with watchdog timer
- **Input signal failure**
: Voltage/current input
Monitoring of range over
: Thermocouple and resistance bulb
Monitoring of disconnection
- **Behavior at failure**
: FLT is indicated, FLT lamp lights, and FLT output signal turns on.

10. Structure

- **Enclosure** : Plastic (material: PC-ABS)
- **Finish color** : Front frame and enclosure both gray
- **Flame resistance**
: UL94V-0
- **Protection** : Front face; IP54 (display unit and operation key)
- **External dimensions (W x H x D)**
: 72 x 144 x 280 mm
- **Mass** : 1.9 kg or less
- **Mounting method**
: Flush on indoor panel
Vertical mounting as standard
Tilted mounting allowed within backward angle 0° to 45°.

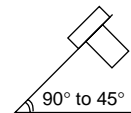

For panel cutout dimension, refer to Panel Cutout Dimensions

- **External terminal**
: Compression terminal type

11. Communications (option)

11-1 RS485 interface-1

- **Communication behavior**
 - : Slave
- **Communication protocol**
 - : Modbus® protocol
- **Physical specification**
 - : EIA RS-485
- **Communication method**
 - : Half-duplex, bit serial
 - : Start-stop synchronizing
- **Connection form**
 - : Multi-drop
- **Communication speed**
 - : 19.2 kbps
- **Communication distance**
 - : Max. 500 m in total
- **Number of connectable units**
 - : Max. 31 units
- **Data length** : Fixed to 8 bits
- **Parity** : Odd / Even / None
- **Stop bit** : 1 or 2
- **Isolation** : Isolated from internal circuit
- **Terminator** : 100 Ω (optional item)
- **Communication items**
 - : Parameters and process value.
- **RS232C / RS485 signal converter (optional item)**
 - : Code symbol: PDZT0001

12. Memory Card Interface (option)

- **Specification** : Compact Flash® (Based on CFA)
- **Compatible memory card**
 - : 5 V flash memory card
 - Capacity 4, 20 and 32 MB
- **Application** : Process data logging (32 points or less)
- **Saving period** : 1s to 2h
- **Data storage capacity**

Memory card capacity	Data storage
4MB	about 180 thousand data
20MB	about 900 thousand data
32MB	about 1.35 million data

[Note] The data of max. 16 points (4 screens) can be stored at storage time as 1 s.

- **Format method**
 - : Dependent on this setter
- **Data readout** : Readout by PC using PCMCIA card slot
- **Recommended memory card**
 - : Made by Sandisk corporation
 - Sandisk compact Flash memory card is standardized and on the market.

13. Standards under Conformity

(1) General safety

: IEC 1010-1 (1990)
EN 61010-1 (1993)

(2) EMC

: Emission EN 50081-2 (1994)
Immunity EN 50082-2 (1995)

Table 1
List of WAFERS

WAFER name	Kinds	Outline
Bit concatenate	8	Outputs digital data as word data to an external expansion I/O.
Bit slicing	1	Slices the digital data acquired as word data from an external expansion I/O into each bit.
Encoder	1	Encodes an input signal into a binary code.
Sawtooth wave generator	1	Generates a sawtooth wave with a slope entered for each cycle time.
BCD	5	Converts BCD data into binary data and binary data into BCD data.
Logical operation	6	Carries out AND,OR,NOT,XOR and a combination of these logical operations.
Arithmetic operation	8	Carries out a combination of addition,subtraction,multiplication and division.
Temperature/pressure compensation	1	Carries out temperature and pressure compensation through use of differential pressure,compensated pressure,proper temperature.
Linearize	7	Carries out segmented-line approximation with 15-segmented-line function.
Flip-flop	1	RS flip-flop.
Pulse width integration	1	Adds the change of input at each basic cycle to the previous integration value.
Selector	1	Compares two input values,and provides High output(Large one), Low output(Small one),and result of judgement on large/small.
Changeover	1	Selects input or output via a switch function.Analog hold circuit also provided.
Timer	1	Outputs on-delay,off-delay timer signal via start of input signal according to timer setting.
Absolute value/sign inversion	1	Carries out absolute value processing on input and outputs the result.Also judges the sign(Positive,negative)of input value and outputs the result.
Square root extraction	1	Extracts square root of input value and outputs the result.Low input cutoff function equipped.
Lead,lag	3	Carries out lead/lag operation on the input and outputs the results. Used as analog filter function and for various compensations.
Limiter	1	Limits the input within the range of high/low limit settings,and outputs the result.Also outputs high/low limit alarm signal.
Ramp function	2	Outputs signal which changes...in ramp from toward target value at the set full scale time.There are two of these wafers...in minute unit and hour unit.
Analog averaging	1	Carries out sequential integration on input data,calculates the average value at each averaging time, and outputs the result.
Analog integration	1	Integrates the value obtained by multiplying the input data by a proportional constant,and outputs the result.
Pulse generation	1	Outputs a pulse at the set time interval.
Dead band	1	Adds dead band compensation to the input and outputs the result.

WAFER name	Kinds	Outline
Pulse No.counter	1	Detects rise of pulse and counts the number of pulses.
Pulse No.output	1	Integrates the input signal and converts it to number of pulses for output.
Decoder	1	Decodes 2-bit pure binary input and outputs it to 4 terminals.
Running average	2	Calculates ranning average of input data and outputs the result.
Sample & hold	1	Holds the input value according to sample signal(0/1)and continues the output.
Dead time	6	Usable for dead time compensation control etc.Data sampling can be done in 1 sec or 1 min units.
ON-OFF	1	Outputs ON-OFF signal with hysteresis.
Alarm	1	Compares the input and set value and outputs the judgment result.
Palse width modurator	1	Performs output processing in time proportional PID control.

A variety of applications are possible through combination of WAFERS.

Table 2

List of Thermocouple and Resistance Bulb Measurable range

	Input signal	Input type code	Input range code	Measurable range°C
Thermocouple	J	01	00	0.0~400.0
	J		01	0.0~800.0
	K		02	0.0~400.0
	K		03	0.0~800.0
	K		04	0.0~1200.0
	R		05	0.0~1600.0
	B		06	0.0~1800.0
	T		07	-200.0~200.0
	T		08	-150.0~400.0
	E		09	0.0~800.0
	E		10	-200.0~800.0
	S		11	0.0~1600.0
	N		12	0.0~1300.0
	U		13	-200.0~400.0
	WRe5-26		14	0.0~2300.0
PL II	15	0.0~1300.0		
Resistance bulb	Pt100	00	00	0.0~150.0
			01	0.0~300.0
			02	0.0~500.0
			03	0.0~600.0
			04	-50.0~100.0
			05	-100.0~200.0
			06	-200.0~600.0
			07	-200.0~850.0

SCOPE OF DELIVERY

Setter, panel mounting bracket, instruction manual (depend on code symbols)

Optional Items

Item	Type	Specificatio	Available unit
Terminator for communication (100 Ω)	PDZR2001	For compression terminal	1
Shunt resistor (250 Ω)	PDZS2001	For compression terminal	1
Communication cable (Note1) For compression terminal, from PD* to PD*	PDZK4xx1	With compression terminal at both ends	1
For compression terminal, from PD* to PLC	PDZK5xx1	With M3.5 solderless terminal on PLC side	1
For compression terminal, from PD* to PC	PDZK6xx1	9-pin connector on PC side	1
Communication converter	PDZT0001	RS232C / RS485 signal converter	1
Setter Instruction Manual in book form (in English)	PDZX3F01	Instruction manual in book form	1
Instruction Manual on CD-ROM (in English)	PDZQ2001	Instruction manual on CD-ROM	1
Mounting bracket	PDZA1001	Improved mounting bracket	1

(Note 1) These cables are used for Modbus®. Length needs to be specified.

Block diagram of electrical isolation

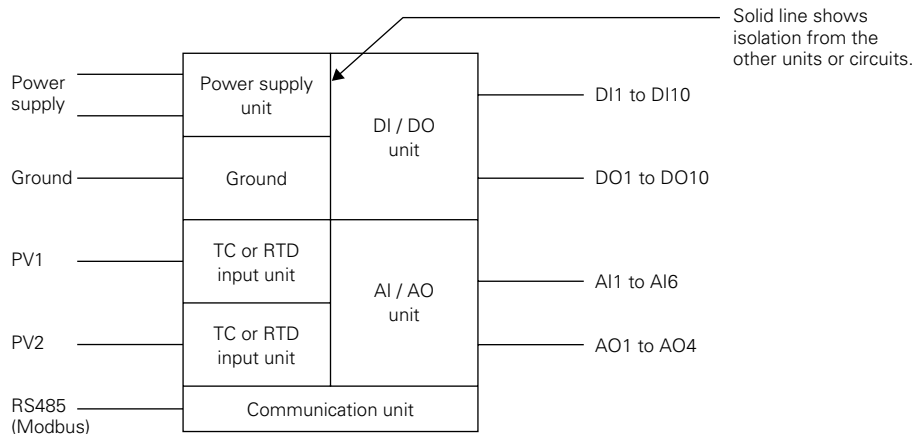

CODE SYMBOLS

1	2	3	4	5	6	7	8	9	10	11	12	13	14	15	Description		
P	D	F	3				1	-			Y		-	Y	Y	Number of loops <5th digit code> 1 loop	
																External terminal <6th digit code> Compression terminal	
																Input signal <7th digit code> 1 to 5 V DC Thermocouple Resistance bulb Pt100	Note 1 Note 2 Note 2
																Power supply voltage <9th digit code> 100V to 240V AC (Usable range 85V to 264V AC) 50 / 60Hz 24V DC (Usable range 20 to 30V DC)	
																Operation mode <10th digit code> Remote-Local changeable type	
																Communication / Memory card interface <12th digit code> (Slave) (Master) (memory card interface)	Note 3 Note 4
																Without Without Without	
																Without Without With	
																RS485 Without Without	Note 5
																RS485 Without With	Note 5
																Instruction manual <13th digit code> Without With Instruction manual on CD-ROM (in Japanese and English)	

- Note 1) For current input, a shunt resistor is used for conversion into voltage. Shunt resistor is optional item.
- Note 2) Thermocouple and resistance bulb input are optional. Allowable up to 2 points.
- Note 3) Communication cable and terminator are optional items.
- Note 4) Recommended maker: Sandisk corporation.
- Note 5) Slave interface is Modbus[®] protocol.
- Note 6) Input signal and measurable range initial set before delivery is as follows.
 For specification of voltage input, scale is 0.00 to 100.00%
 For specification of thermocouple, K, 0.0 to 400.0°C.
 For specification of resistance bulb is 0.0 to 150.0°C.

OUTLINE DIAGRAM (Unit : mm)

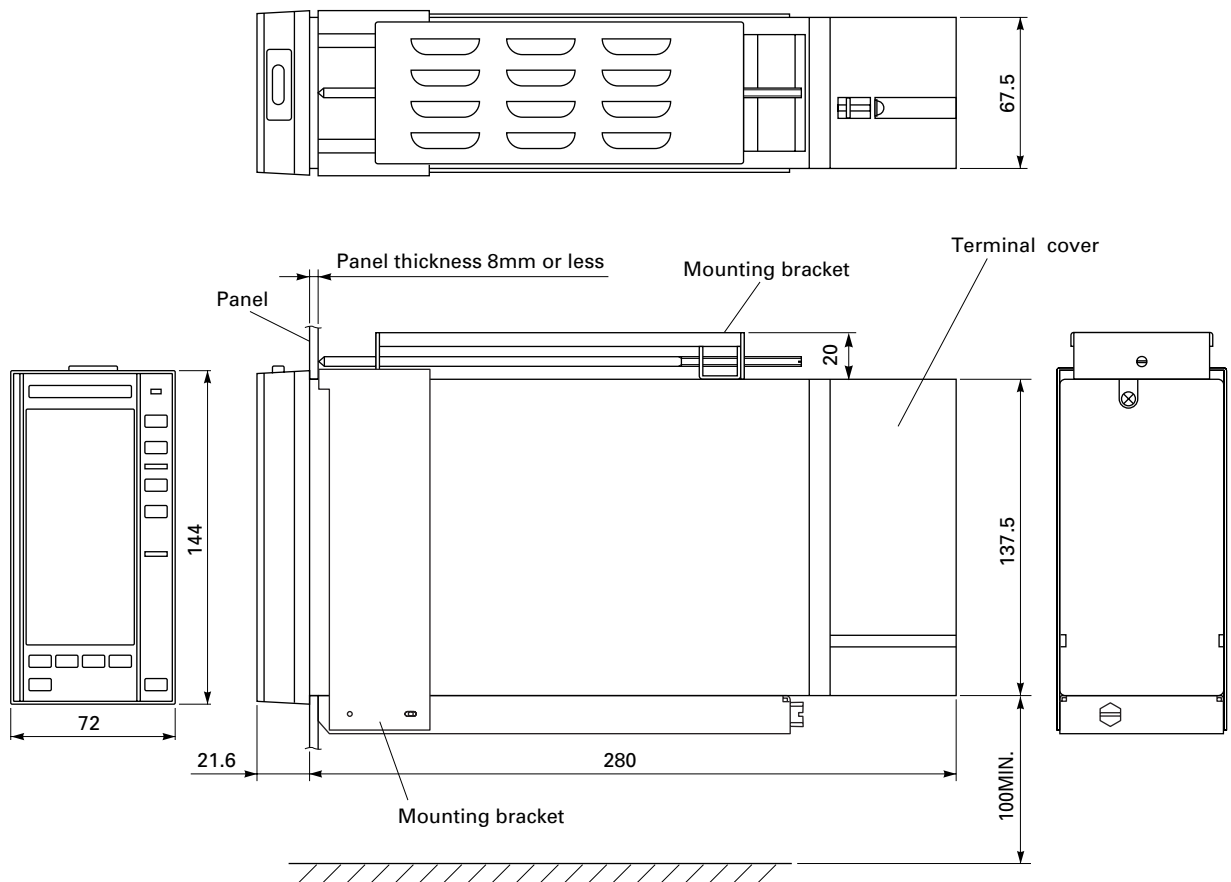

Note) The distance between other instruments and low end of PDF shall be more than 100mm.

MOUNTING BRACKET

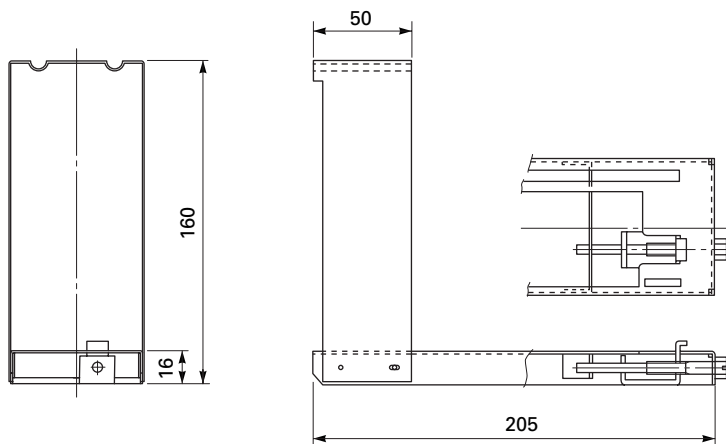

PANEL CUTOUT DIMENSIONS

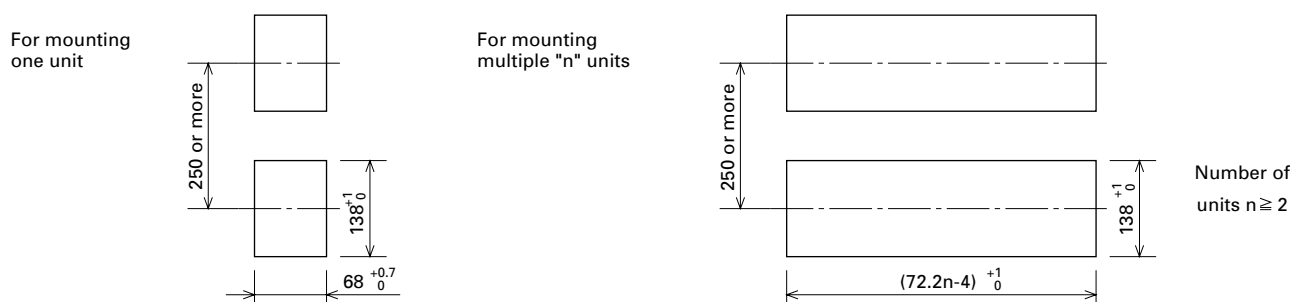

EXTERNAL CONNECTION DIAGRAM

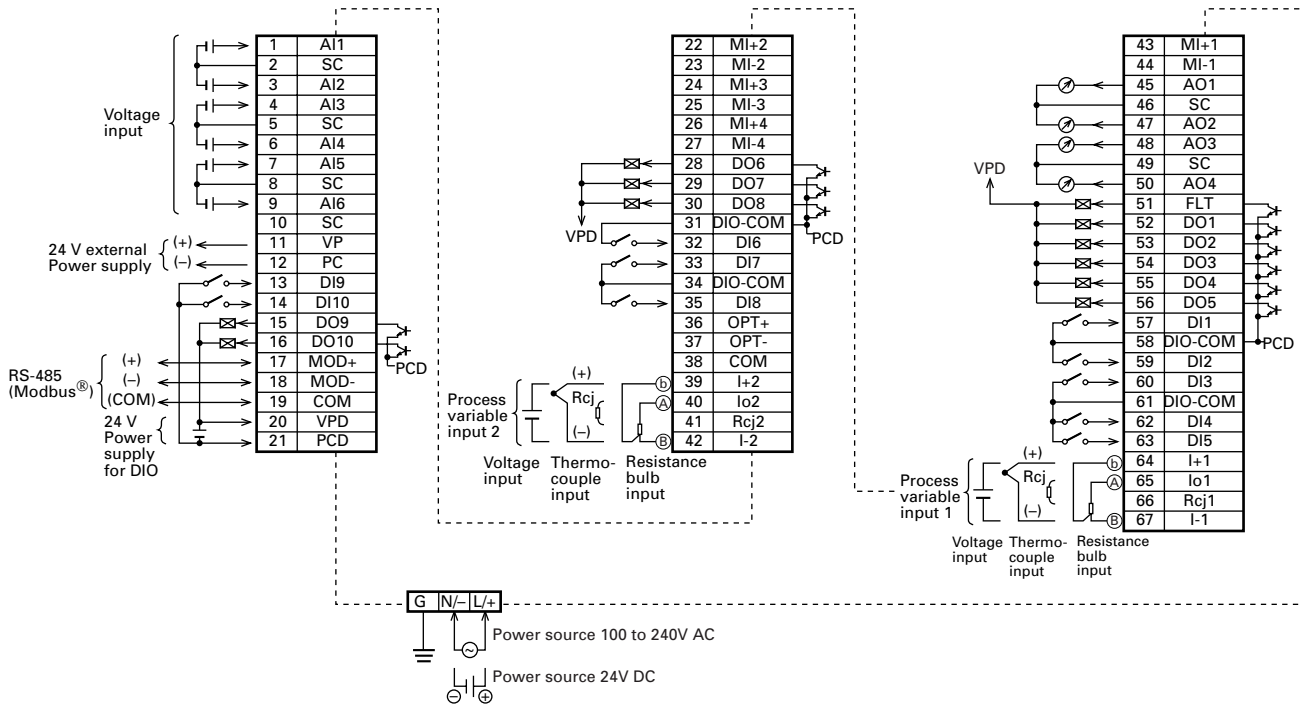

INPUT/OUTPUT TERMINAL FUNCTION (when preset WAFER)

	Input signal name	Input terminal	Output signal name	Output terminal
Analog	PV input	I+1, I-1	Universal analog output	AO1
	External set value input (RSV)	I+2, I-2	Universal analog output	AO2
	Universal analog input	AI1	PV compensation signal (KPV)	AO3
	Universal analog input	AI2	Set value output signal (SV)	AO4
	Universal analog input	AI3	Don't use	MI+1, MI-1
	Universal analog input	AI4	Don't use	MI+2, MI-2
	Universal analog input	AI5	Don't use	MI+3, MI-3
	Universal analog input	AI6	Don't use	MI+4, MI-4
Digital	Universal digital input	DI1	Universal digital output	DO1
	Universal digital input	DI2	Universal digital output	DO2
	Universal digital input	DI3	Universal digital output	DO3
	Universal digital input	DI4	Universal digital output	DO4
	Universal digital input	DI5	Universal digital output	DO5
	Universal digital input	DI6	Universal digital output	DO6
	Universal digital input	DI7	Local mode output (LS)	DO7
	Remote acknowledge signal (R-ACK)	DI8	Remote request (R-REQ)	DO8
	Universal digital input	DI9	Upper alarm output (H)	DO9
	Universal digital input	DI10	Lower alarm output (L)	DO10
			Fault output (FLT-DO)	FLT
			Don't use	OPT+
			Don't use	OPT-

[Note] Windows® is the registered trade mark of Microsoft corporation.

[Note] Modbus® is the registered trade mark of Gould Modicon.

[Note] Compact Flash® is the registered trade mark of Sandisk corporation.

⚠ Caution on Safety

*Before using this product, be sure to read its instruction manual in advance.

Fuji Electric Systems Co., Ltd.

Head Office

Gate City Ohsaki, East Tower, 11-2, Osaki 1-chome,
Shinagawa-ku, Tokyo 141-0032, Japan

<http://www.fesys.co.jp/eng>

Instrumentation Div.

International Sales Dept.

No.1, Fuji-machi, Hino-city, Tokyo, 191-8502 Japan

Phone: 81-42-585-6201, 6202 Fax: 81-42-585-6187

<http://www.fic-net.jp/eng>

Information in this catalog is subject to change without notice.

Printed in Japan