

# ABSOLUTE PRESSURE TRANSMITTER

DATA SHEET

FKA...5

The FCX-AIII absolute pressure transmitter accurately measures absolute pressure and transmits a proportional 4 to 20mA signal.

The transmitter utilizes a unique micromachined capacitance silicon sensor with state-of-the-art microprocessor technology to provide exceptional performance and functionality.

## FEATURES

### 1. High accuracy

0.2% accuracy for all calibrated spans is a standard feature for all AP models covering 1.6kPa {0.016bar} range to 3000kPa {30bar} high pressure range. 0.1% accuracy is available as option. Fuji's micro-capacitance silicon sensor assures this accuracy for all suppressed calibration ranges without additional adjustment.

### 2. Minimum environmental influence

The "Advanced Floating Cell" design which protects the pressure sensor against changes in temperature, and overpressure substantially reduces total measurement error in actual field applications.

### 3. Fuji/HART® bilingual communications protocol

FCX-AIII series transmitter offers bilingual communications to speak both Fuji proprietary protocol and HART®. Any HART® compatible devices can communicate with FCX-AIII.

### 4. Application flexibility

Various options that render the FCX-AIII suitable for almost any process applications include:

- Full range of hazardous area approvals
- Built-in RFI filter and lightning arrester
- 5-digit LCD meter with engineering unit
- Stainless steel electronics housing
- Wide selection of materials

### 5. Burnout current flexibility (Under Scale: 3.2 to 4.0mA, Over Scale: 20.0 to 22.5mA)

Burnout signal level is adjustable using Model FXW Hand Held Communicator (HHC) to comply with NAMUR NE43.

### 6. Dry calibration without reference pressure

Thanks to the best combination of unique construction of mechanical parts (Sensor unit) and high performance electronics circuit (Electronics unit), reliability of dry calibration without reference pressure is at equal level as wet calibration.

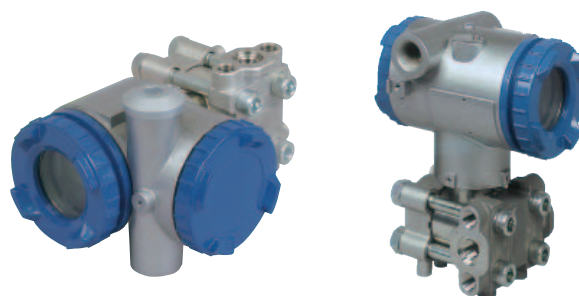

[ L-Type ]

[ T-Type ]

## SPECIFICATIONS

### Functional specifications

**Service:** Liquid, gas, or vapour

**Span, range, and overrange limit:**

| Type   | Span limit<br>[kPa abs] [bar abs] |              | Range limit<br>[kPa abs]<br>[bar abs] | Overrange<br>limit<br>[MPa]<br>[bar] |
|--------|-----------------------------------|--------------|---------------------------------------|--------------------------------------|
|        | Min.                              | Max.         |                                       |                                      |
| FKA□01 | 1.6<br>{0.016}                    | 16<br>{0.16} | 0 to +16<br>{0 to +0.16}              | 0.5<br>{5}                           |
| FKA□02 | 1.6<br>{0.016}                    | 130<br>{1.3} | 0 to +130<br>{0 to +1.3}              | 0.5<br>{5}                           |
| FKA□03 | 5<br>{0.05}                       | 500<br>{5}   | 0 to +500<br>{0 to +5}                | 1.5<br>{15}                          |
| FKA□04 | 30<br>{0.3}                       | 3000<br>{30} | 0 to +3000<br>{0 to +30}              | 9<br>{90}                            |

**Remark:** To minimize environmental influence, span should be greater than 1/40 of the max. span in most applications.

- The maximum span of each sensor can be converted to different units using factors as below.

1MPa abs=10<sup>3</sup>kPa abs=10bar abs=10.19716kgf/cm<sup>2</sup> abs  
=145.0377psi abs

1kPa abs =10mbar abs=101.9716mmH<sub>2</sub>O abs  
=4.01463inH<sub>2</sub>O abs=7.50062mmHg abs

**Output signal:** 4 to 20mA DC with digital signal superimposed on the 4 to 20mA signal.

**Power supply:** Transmitter operates on 10.5V to 45V DC at transmitter terminals.  
10.5V to 32V DC for the units with optional arrester.

Load limitations: see figure below

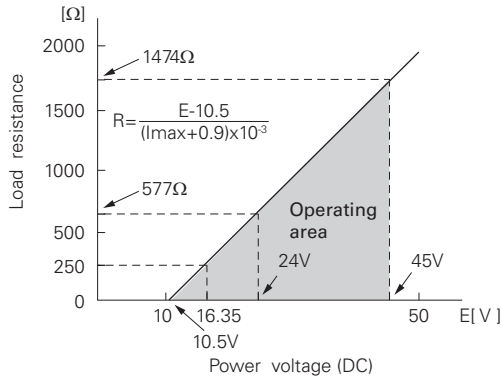

Note: For communication with HHC<sup>(1)</sup> (Model: FXW), min. of 250Ω is required.

Hazardous locations: SEE TABLE2

Zero/span adjustment:

Zero and span are adjustable from the HHC<sup>(1)</sup>. Zero and span are also adjustable externally from the adjustment screw.

Damping:

Adjustable from HHC or local configurator unit with LCD display. The time constant is adjustable between 0.06 to 32 seconds.

Zero elevation/suppression:

Zero can be elevated within the specified range limit of each sensor model.

Normal/reverse action:

Selectable from HHC<sup>(1)</sup>.

Indication:

Analog indicator or 5-digit LCD meter, as specified.

Burnout direction: Selectable from HHC<sup>(1)</sup>

If self-diagnostic detect transmitter failure, the analog signal will be driven to either "Output Hold", "Output Overscale" or "Output Underscale" modes.

"Output Hold":

Output signal is hold as the value just before failure happens.

"Output Overscale":

Adjustable within the range 20.0mA to 22.5mA from HHC<sup>(1)</sup>

"Output Underscale":

Adjustable within the range 3.2mA to 4.0mA from HHC<sup>(1)</sup>

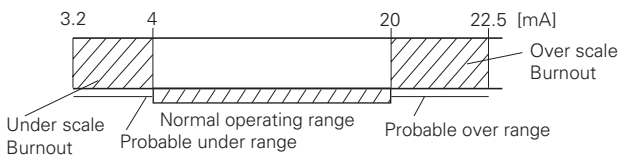

Output Limits conforming to the NAMUR NE43 by order.

Loop-check output:

Transmitter can be configured to provide constant signal 3.2mA through 22.5mA by HHC<sup>(1)</sup>.

Temperature limit:

Ambient: -40 to +85°C

(-20 to +80°C for LCD indicator)

(-40 to +60°C for arrester option)

For explosionproof units (flameproof or intrinsic safety), ambient temperature must be within the limits specified by each standard.

Process: -40 to +85°C for silicone fill sensor

Storage: -40 to +90°C

Humidity limit: 0 to 100% RH

Communication: With HHC<sup>(1)</sup> (Model FXW, consult Data Sheet No. EDS8-47), following items can be remotely displayed or configured.

Note: HHC's version must be higher than 7.0 (or FXW □□□□1-□4), for FCX-AIII.

Local configurator with LCD display (option):

Local configurator with 3 push button and LCD display can support following items.

| Items  | By communication with FXW |     | By local configurator (with 3 push button) |     |
|--|---------------------------|-----|--|-----|
|  | Display                   | Set | Display                                    | Set |
| Tag No.                                      | ✓                         | ✓   | ✓  | ✓   |
| Model No.                                    | ✓                         | ✓   | ✓  | ✓   |
| Serial No. & Software Version                | ✓                         | —   | ✓  | —   |
| Engineering unit                             | ✓                         | ✓   | ✓  | ✓   |
| Range limit                                  | ✓                         | —   | ✓  | —   |
| Measuring range                              | ✓                         | ✓   | ✓  | ✓   |
| Damping                                      | ✓                         | ✓   | ✓  | ✓   |
| Output mode                                  | ✓                         | —   | ✓  | —   |
| Burnout direction                            | ✓                         | ✓   | ✓  | ✓   |
| Calibration                                  | ✓                         | ✓   | ✓  | ✓   |
| Output adjust                                | —                         | ✓   | —  | ✓   |
| Data   | ✓                         | —   | ✓  | —   |
| Self diagnoses                               | ✓                         | —   | ✓  | —   |
| Printer (In case of FXW with printer option) | ✓                         | —   | —  | —   |
| External switch lock                         | ✓                         | ✓   | ✓  | ✓   |
| Transmitter display                          | ✓                         | ✓   | ✓  | ✓   |
| Linearize                                    | ✓                         | ✓   | —  | —   |
| Rerange                                      | ✓                         | ✓   | ✓  | ✓   |
| Saturate current                             | ✓                         | ✓   | ✓  | ✓   |
| Write protect                                | ✓                         | ✓   | ✓  | ✓   |
| History                                      |                           |     |  |     |
| - Calibration history                        | ✓                         | ✓   | ✓  | ✓   |
| - Ambient temperature history                | ✓                         | —   | ✓  | —   |

EMC Conformity: EN61326-1: 2006 CE

(Note) (1) HHC: Hand Held Communicator

## Performance specifications

Reference conditions, silicone oil fill, 316SS isolating diaphragms, 4 to 20mA analog output in linear mode.

**Accuracy rating:** (including linearity, hysteresis, and repeatability).

(Standard)

For spans greater than 1/10 of URL:  $\pm 0.2\%$  of span

For spans below 1/10 of URL:

$$\pm \left( 0.1 + 0.1 \frac{0.1 \times \text{URL}}{\text{Span}} \right) \% \text{ of span}$$

(Option) (code: 21th digit H)

(Not available for Max span 16kPa abs, 130kPa abs)

For spans greater than 1/10 of URL:  $\pm 0.1\%$  of span

For spans below 1/10 of URL:

$$\pm \left( 0.05 + 0.05 \frac{0.1 \times \text{URL}}{\text{Span}} \right) \% \text{ of span}$$

**Stability:**  $\pm 0.2\%$  of upper range limit (URL) for 10 years.

**Temperature effect:**

Effect per 28°C change between the limits of -40°C and +85°C

$$\text{Zero shift: } \pm \left( 0.125 + 0.1 \frac{\text{URL}}{\text{Span}} \right) \%$$

$$\text{Total effect: } \pm \left( 0.15 + 0.1 \frac{\text{URL}}{\text{Span}} \right) \%$$

**Overrange effect:** Zero shift;  $\pm 0.2\%$  of URL for any overrange to maximum limit

**Supply voltage effect:**

Less than 0.005% of calibrated span per 1V

**Update rate:** 60 msec

**Step response:** Time constant: 0.08 s (at 23°C)

Dead time: 0.12 s

(without electrical damping)

**Mounting position effect:**

Zero shift, less than 0.1kPa{1mbar} for a 10° tilt in any plane.

No effect on span. This error can be corrected by adjusting zero.

**Dielectric strength:**

500V AC, 50/60Hz 1 min., between circuit and earth.

**Insulation resistance:**

More than 100MΩ at 500V DC.

**Internal resistance for external field indicator:**

12Ω or less

## Physical specifications

**Electrical connections:**

G1/2, 1/2-14NPT, Pg13.5, or M20 x 1.5 conduit, as specified.

**Process connections:**

1/4-18 NPT or Rc1/4 on 54mm centers, as specified.

## Process-wetted parts material:

| Material code (7th digit in "Code symbols") | Process cover           | Diaphragm            | Wetted sensor body  | Vent/drain               |
|---|-------------------------|----------------------|---------------------|--------------------------|
| V   | 316 stainless steel (*) | 316L stainless steel | 316 stainless steel | 316/316L stainless steel |
| H   | 316 stainless steel (*) | Hastelloy-C          | Hastelloy-C lining  | 316/316L stainless steel |
| M   | 316 stainless steel (*) | Monel                | Monel lining        | 316/316L stainless steel |
| T   | 316 stainless steel (*) | Tantalum             | Tantalum lining     | 316/316L stainless steel |

Note: (\*) SCS14A per JIS G 5121 (equivalent CF8M per ASTM A351/A351M)

Remarks: Availability of above material design depends on ranges. Refer to "Code symbols".

## Non-wetted parts material:

Electronics housing: Low copper die-cast aluminum alloy finished with polyester coating (standard), or 316 stainless steel (ASTM CF8M), as specified.

Bolts and nut: Cr-Mo alloy (standard), 304 or 316 stainless steel

Fill fluid: Silicone oil

Mounting bracket: 304 or 316 stainless steel.

## Environmental protection:

IEC IP67 and NEMA 6/6P

## Mounting:

On 60.5mm (JIS 50A) pipe using mounting bracket, direct wall mounting, or direct process mounting.

## Mass{weight}:

Transmitter approximately 2.9 to 3.4kg without options.

Add; 0.5kg for mounting bracket

4.5kg for stainless steel housing option

## Optional features

### Indicator:

A plug-in analog indicator (2.5% accuracy)

An optional 5-digit LCD meter with engineering unit is also available.

### Local configurator with LCD display:

An optional 5 digits LCD meter with 3 push buttons can support items as using communication with FXW.

### Arrester:

A built-in arrester protects the electronics from lightning surges.

Lightning surge immunity:

4kV (1.2 × 50μs)

### Degreasing:

Process-wetted parts are cleaned, but the fill fluid is standard silicone oil. Not for use on oxygen or chlorine measurement.

### NACE specification:

Metallic materials for all pressure boundary parts comply with NACE MR-01-75. 304 stainless steel bolts and nuts, ASTM B7M or L7M bolts and 2HM nuts (Class II) are available.

### Optional tagplate:

An extra stainless steel tag for customer tag data is wired to the transmitter.

### Coating of cell:

Cell's surface is finished with epoxy/polyurethane double coating. Specify if environment is extremely corrosive.

CODE SYMBOLS

| Digit  | Description   |                     |                               |                     | Note  | 1 | 2 | 3 | 4 | 5  | 6  | 7 | 8 | 9 | 10 | 11 | 12 | 13 | 14 | 15 | 21 |   |   |   |
|--|---|---------------------|-------------------------------|---------------------|-------|---|---|---|---|----|----|---|---|---|----|----|----|----|----|----|----|---|---|---|
|  |   |                     |                               |                     |       | F | K | A | 0 | 5  | -  | - | - | - | -  | -  | -  | -  | -  | -  | -  | - | - | - |
| 4  | <Connections>   |                     |                               |                     |       |   |   |   |   |    |    |   |   |   |    |    |    |    |    |    |    |   |   |   |
|  | Process connection                                    | Oval flange screw   | Conduit connection            | Case type           |       |   |   |   |   |    |    |   |   |   |    |    |    |    |    |    |    |   |   |   |
|  | Rc1/4   | 7/16-20UNF          | G1/2                          | T type              |       |   |   |   |   | 5  |    |   |   |   |    |    |    |    |    |    |    |   |   |   |
|  | 1/4-18NPT   | 7/16-20UNF          | 1/2-14NPT                     | T type              |       |   |   |   |   | 6  |    |   |   |   |    |    |    |    |    |    |    |   |   |   |
|  | 1/4-18NPT   | M10                 | Pg13.5                        | T type              |       |   |   |   |   | 7  |    |   |   |   |    |    |    |    |    |    |    |   |   |   |
|  | 1/4-18NPT   | M10                 | M20x1.5                       | T type              |       |   |   |   |   | 8  |    |   |   |   |    |    |    |    |    |    |    |   |   |   |
|  | 1/4-18NPT   | 7/16-20UNF          | Pg13.5                        | T type              |       |   |   |   |   | 9  |    |   |   |   |    |    |    |    |    |    |    |   |   |   |
|  | Rc1/4   | 7/16-20UNF          | G1/2                          | L type              |       |   |   |   |   | S  |    |   |   |   |    |    |    |    |    |    |    |   |   |   |
|  | 1/4-18NPT   | 7/16-20UNF          | 1/2-14NPT                     | L type              |       |   |   |   |   | T  |    |   |   |   |    |    |    |    |    |    |    |   |   |   |
|  | 1/4-18NPT   | M10                 | Pg13.5                        | L type              |       |   |   |   |   | V  |    |   |   |   |    |    |    |    |    |    |    |   |   |   |
| 1/4-18NPT  | M10   | M20x1.5             | L type                        |                     |       |   |   |   | W |    |    |   |   |   |    |    |    |    |    |    |    |   |   |   |
| 1/4-18NPT  | 7/16-20UNF  | Pg13.5              | L type                        |                     |       |   |   |   | X |    |    |   |   |   |    |    |    |    |    |    |    |   |   |   |
| 6, 7   | <Span limit>  |                     |                               |                     |       |   |   |   |   |    |    |   |   |   |    |    |    |    |    |    |    |   |   |   |
|  | Span limit [kPa abs](bar abs)(*1)                     | Process cover       | Diaphragm                     | Wetted cell body    | Note1 |   |   |   |   |    |    |   |   |   |    |    |    |    |    |    |    |   |   |   |
|  | 1.6...16<br>{0.016...0.16}                            | 316 stainless steel | 316L stainless steel          | 316 stainless steel |       |   |   |   |   |    | 1V |   |   |   |    |    |    |    |    |    |    |   |   |   |
|  |   | 316 stainless steel | Hast. C                       | Hast. C lining      |       |   |   |   |   |    | 1H |   |   |   |    |    |    |    |    |    |    |   |   |   |
|  |   | 316 stainless steel | Monel                         | Monel lining        |       |   |   |   |   |    | 1M |   |   |   |    |    |    |    |    |    |    |   |   |   |
|  | 1.6...130<br>{0.016...1.3}                            | 316 stainless steel | 316L stainless steel          | 316 stainless steel |       |   |   |   |   |    | 2V |   |   |   |    |    |    |    |    |    |    |   |   |   |
|  |   | 316 stainless steel | Hast. C                       | Hast. C lining      |       |   |   |   |   |    | 2H |   |   |   |    |    |    |    |    |    |    |   |   |   |
|  |   | 316 stainless steel | Monel                         | Monel lining        |       |   |   |   |   |    | 2M |   |   |   |    |    |    |    |    |    |    |   |   |   |
|  |   | 316 stainless steel | Tantalum                      | Tantalum lining     |       |   |   |   |   |    | 2T |   |   |   |    |    |    |    |    |    |    |   |   |   |
|  | 5...500<br>{0.05...5}                                 | 316 stainless steel | 316L stainless steel          | 316 stainless steel |       |   |   |   |   |    | 3V |   |   |   |    |    |    |    |    |    |    |   |   |   |
|  |   | 316 stainless steel | Hast. C                       | Hast. C lining      |       |   |   |   |   |    | 3H |   |   |   |    |    |    |    |    |    |    |   |   |   |
|  |   | 316 stainless steel | Monel                         | Monel lining        |       |   |   |   |   |    | 3M |   |   |   |    |    |    |    |    |    |    |   |   |   |
|  |   | 316 stainless steel | Tantalum                      | Tantalum lining     |       |   |   |   |   |    | 3T |   |   |   |    |    |    |    |    |    |    |   |   |   |
|  | 30...3000<br>{0.3...30}                               | 316 stainless steel | 316L stainless steel          | 316 stainless steel |       |   |   |   |   |    | 4V |   |   |   |    |    |    |    |    |    |    |   |   |   |
|  |   | 316 stainless steel | Hast. C                       | Hast. C lining      |       |   |   |   |   |    | 4H |   |   |   |    |    |    |    |    |    |    |   |   |   |
|  |   | 316 stainless steel | Monel                         | Monel lining        |       |   |   |   |   |    | 4M |   |   |   |    |    |    |    |    |    |    |   |   |   |
| 316 stainless steel                                |   | Tantalum            | Tantalum lining               |                     |       |   |   |   |   | 4T |    |   |   |   |    |    |    |    |    |    |    |   |   |   |
|  |   |                     |                               |                     |       |   |   |   |   |    |    |   |   |   |    |    |    |    |    |    |    |   |   |   |
| 9  | <Indicator and arrester>                              |                     |                               |                     |       |   |   |   |   |    |    |   |   |   |    |    |    |    |    |    |    |   |   |   |
|  | <u>Indicator</u>                                      |                     | <u>Arrester</u>               |                     |       |   |   |   |   |    |    |   |   |   |    |    |    |    |    |    |    |   |   |   |
|  | None  |                     | None                          |                     |       |   |   |   |   |    |    |   |   |   |    |    |    |    |    |    |    |   |   |   |
|  | Analog, 0 to 100% linear scale                        |                     | None                          |                     |       |   |   |   |   |    |    |   |   |   |    |    |    |    |    |    |    |   |   |   |
|  | Analog, custom scale                                  |                     | None                          |                     |       |   |   |   |   |    |    |   |   |   |    |    |    |    |    |    |    |   |   |   |
|  | None  |                     | Yes                           |                     |       |   |   |   |   |    |    |   |   |   |    |    |    |    |    |    |    |   |   |   |
|  | Analog, 0 to 100% linear scale                        |                     | Yes                           |                     |       |   |   |   |   |    |    |   |   |   |    |    |    |    |    |    |    |   |   |   |
|  | Analog, custom scale                                  |                     | Yes                           |                     |       |   |   |   |   |    |    |   |   |   |    |    |    |    |    |    |    |   |   |   |
|  | Digital, 0 to 100% linear scale                       |                     | None                          |                     |       |   |   |   |   |    |    |   |   |   |    |    |    |    |    |    |    |   |   |   |
|  | Digital, custom scale                                 |                     | None                          |                     |       |   |   |   |   |    |    |   |   |   |    |    |    |    |    |    |    |   |   |   |
|  | Digital, 0 to 100% linear scale                       |                     | Yes                           |                     |       |   |   |   |   |    |    |   |   |   |    |    |    |    |    |    |    |   |   |   |
|  | Digital, custom scale                                 |                     | Yes                           |                     |       |   |   |   |   |    |    |   |   |   |    |    |    |    |    |    |    |   |   |   |
|  | Digital, 0 to 100% linear scale                       |                     | None                          |                     |       |   |   |   |   |    |    |   |   |   |    |    |    |    |    |    |    |   |   |   |
|  | (Local configurator unit with LCD display)            |                     | None                          |                     |       |   |   |   |   |    |    |   |   |   |    |    |    |    |    |    |    |   |   |   |
|  | Digital, custom scale                                 |                     | None                          |                     |       |   |   |   |   |    |    |   |   |   |    |    |    |    |    |    |    |   |   |   |
|  | (Local configurator unit with LCD display)            |                     | None                          |                     |       |   |   |   |   |    |    |   |   |   |    |    |    |    |    |    |    |   |   |   |
| Digital, 0 to 100% linear scale                    |   | Yes                 |                               |                     |       |   |   |   |   |    |    |   |   |   |    |    |    |    |    |    |    |   |   |   |
| (Local configurator unit with LCD display)         |   | Yes                 |                               |                     |       |   |   |   |   |    |    |   |   |   |    |    |    |    |    |    |    |   |   |   |
| Digital, custom scale                              |   | Yes                 |                               |                     |       |   |   |   |   |    |    |   |   |   |    |    |    |    |    |    |    |   |   |   |
| (Local configurator unit with LCD display)         |   | Yes                 |                               |                     |       |   |   |   |   |    |    |   |   |   |    |    |    |    |    |    |    |   |   |   |
| 10   | <Approvals for hazardous locations>                   |                     |                               |                     |       |   |   |   |   |    |    |   |   |   |    |    |    |    |    |    |    |   |   |   |
|  | None (for ordinary locations)                         |                     |                               |                     |       |   |   |   |   |    |    |   |   |   |    |    |    |    |    |    |    |   |   |   |
|  | TIIS, Flameproof (Conduit seal) (*6)                  |                     |                               |                     | Note6 |   |   |   |   |    |    |   |   |   |    |    |    |    |    |    |    |   |   |   |
|  | TIIS, Flameproof (Cable gland seal) (*6)              |                     |                               |                     | Note6 |   |   |   |   |    |    |   |   |   |    |    |    |    |    |    |    |   |   |   |
|  | TIIS, Intrinsic safety                                |                     |                               |                     |       |   |   |   |   |    |    |   |   |   |    |    |    |    |    |    |    |   |   |   |
|  | FM, Flameproof (or explosionproof) (*9)               |                     |                               |                     | Note9 |   |   |   |   |    |    |   |   |   |    |    |    |    |    |    |    |   |   |   |
|  | FM, Intrinsic safety and nonincensive                 |                     |                               |                     |       |   |   |   |   |    |    |   |   |   |    |    |    |    |    |    |    |   |   |   |
|  | FM Combined of flameproof and intrinsic safety (*9)   |                     |                               |                     | Note9 |   |   |   |   |    |    |   |   |   |    |    |    |    |    |    |    |   |   |   |
|  | ATEX Flameproof (*8)                                  |                     |                               |                     | Note8 |   |   |   |   |    |    |   |   |   |    |    |    |    |    |    |    |   |   |   |
|  | ATEX Intrinsic safety                                 |                     |                               |                     |       |   |   |   |   |    |    |   |   |   |    |    |    |    |    |    |    |   |   |   |
|  | ATEX Type n   |                     |                               |                     |       |   |   |   |   |    |    |   |   |   |    |    |    |    |    |    |    |   |   |   |
|  | ATEX Combined of flameproof and intrinsic safety (*8) |                     |                               |                     | Note8 |   |   |   |   |    |    |   |   |   |    |    |    |    |    |    |    |   |   |   |
|  | IECEx Scheme, Flameproof (*8)                         |                     |                               |                     | Note8 |   |   |   |   |    |    |   |   |   |    |    |    |    |    |    |    |   |   |   |
|  | IECEx Scheme, Intrinsic safety                        |                     |                               |                     |       |   |   |   |   |    |    |   |   |   |    |    |    |    |    |    |    |   |   |   |
|  | CSA, Flameproof (or explosionproof) (*9)              |                     |                               |                     | Note9 |   |   |   |   |    |    |   |   |   |    |    |    |    |    |    |    |   |   |   |
|  | CSA, Intrinsic safety and nonincensive                |                     |                               |                     |       |   |   |   |   |    |    |   |   |   |    |    |    |    |    |    |    |   |   |   |
| NEPSI, Flameproof (or explosionproof)              |   |                     |                               |                     |       |   |   |   |   |    |    |   |   |   |    |    |    |    |    |    |    |   |   |   |
| NEPSI, Intrinsic safety                            |   |                     |                               |                     |       |   |   |   |   |    |    |   |   |   |    |    |    |    |    |    |    |   |   |   |
| NEPSI, Combined of flameproof and intrinsic safety |   |                     |                               |                     |       |   |   |   |   |    |    |   |   |   |    |    |    |    |    |    |    |   |   |   |
| 11   | <Vent/ drain and mounting bracket>                    |                     |                               |                     |       |   |   |   |   |    |    |   |   |   |    |    |    |    |    |    |    |   |   |   |
|  | <u>Vent/drain</u>                                     |                     | <u>Mounting bracket</u>       |                     |       |   |   |   |   |    |    |   |   |   |    |    |    |    |    |    |    |   |   |   |
|  | Standard  |                     | None                          |                     |       |   |   |   |   |    |    |   |   |   |    |    |    |    |    |    |    |   |   |   |
|  | Standard  |                     | Yes, stainless steel (SUS304) |                     |       |   |   |   |   |    |    |   |   |   |    |    |    |    |    |    |    |   |   |   |
|  | Standard  |                     | Yes, stainless steel (SUS316) |                     |       |   |   |   |   |    |    |   |   |   |    |    |    |    |    |    |    |   |   |   |
|  | Side  |                     | None                          |                     |       |   |   |   |   |    |    |   |   |   |    |    |    |    |    |    |    |   |   |   |
|  | Side  |                     | Yes, stainless steel (SUS304) |                     |       |   |   |   |   |    |    |   |   |   |    |    |    |    |    |    |    |   |   |   |
|  | Side  |                     | Yes, stainless steel (SUS316) |                     |       |   |   |   |   |    |    |   |   |   |    |    |    |    |    |    |    |   |   |   |

Note1: (\*1) 100: 1 turn down is possible, but should be used at a span greater than 1/40 of the maximum span for better performance.

| Digit  | Description  | Note                          | 1               | 2 | 3 | 4 | 5 | 6 | 7 | 8 | 9 | 10 | 11 | 12 | 13 | 14 | 15 | 21 | ← Digit No. of code |
|--|--|-------------------------------|-----------------|---|---|---|---|---|---|---|---|----|----|----|----|----|----|----|---------------------|
| 12   | <Options>  |                               | F               | K | A | 0 | 5 |   |   |   |   |    |    |    |    |    |    |    |                     |
|  | Extra SS tag plate   | Stainless steel elec. housing | Coating of cell |   |   |   |   |   |   |   |   |    |    |    |    |    |    |    |                     |
|  | None   | None                          | None            |   |   |   |   |   |   |   |   |    |    |    |    |    |    |    |                     |
|  | Yes  | None                          | None            |   |   |   |   |   |   |   |   |    |    |    |    |    |    |    |                     |
|  | None   | None                          | Yes             |   |   |   |   |   |   |   |   |    |    |    |    |    |    |    |                     |
|  | Yes  | None                          | Yes             |   |   |   |   |   |   |   |   |    |    |    |    |    |    |    |                     |
| 13   | <Special applications and fill fluid>  |                               |                 |   |   |   |   |   |   |   |   |    |    |    |    |    |    |    |                     |
|  | Treatment  | Fill fluid                    |                 |   |   |   |   |   |   |   |   |    |    |    |    |    |    |    |                     |
|  | Standard   | Silicone oil                  |                 |   |   |   |   |   |   |   |   |    |    |    |    |    |    |    |                     |
|  | Degreasing   | Silicone oil                  |                 |   |   |   |   |   |   |   |   |    |    |    |    |    |    |    |                     |
| NACE specification                               | Silicone oil (7th digit code "T" and 15th digit code "A", "B" are not available) |                               |                 |   |   |   |   |   |   |   |   |    |    |    |    |    |    |    |                     |
| 14   | <O-ring/Gasket and Teflon membrane><br>Teflon (gasket)                           |                               |                 |   |   |   |   |   |   |   |   |    |    |    |    |    |    |    |                     |
| 15   | <Bolt/nut> (*3)  |                               |                 |   |   |   |   |   |   |   |   |    |    |    |    |    |    |    |                     |
|  | Cr-Mo alloy hexagon socket head cap screw/carbon steel nut                       |                               |                 |   |   |   |   |   |   |   |   |    |    |    |    |    |    |    |                     |
|  | Cr-Mo alloy hexagon bolt/nut   |                               |                 |   |   |   |   |   |   |   |   |    |    |    |    |    |    |    |                     |
|  | NACE bolt/nut (ASTM A193 B7M/A194 2HM)   |                               |                 |   |   |   |   |   |   |   |   |    |    |    |    |    |    |    |                     |
|  | NECE bolt/nut (ASTM A320 L7M/A194 2HM)   |                               |                 |   |   |   |   |   |   |   |   |    |    |    |    |    |    |    |                     |
|  | 304 stainless steel bolt/304 stainless steel nut                                 |                               |                 |   |   |   |   |   |   |   |   |    |    |    |    |    |    |    |                     |
| 316 stainless steel bolt/316 stainless steel nut |  |                               |                 |   |   |   |   |   |   |   |   |    |    |    |    |    |    |    |                     |
| 21   | <Other options> (*4)   |                               |                 |   |   |   |   |   |   |   |   |    |    |    |    |    |    |    |                     |
|  | High accuracy type (*7)  | Instruction manual attached   |                 |   |   |   |   |   |   |   |   |    |    |    |    |    |    |    |                     |
|  | Opposite Vent/Drain Plug Position  | Instruction manual attached   |                 |   |   |   |   |   |   |   |   |    |    |    |    |    |    |    |                     |
|  | Instruction manual unattached  |                               |                 |   |   |   |   |   |   |   |   |    |    |    |    |    |    |    |                     |
| High accuracy type(*7)                           | Instruction manual unattached  |                               |                 |   |   |   |   |   |   |   |   |    |    |    |    |    |    |    |                     |
| Opposite Vent/Drain Plug Position                | Instruction manual unattached  |                               |                 |   |   |   |   |   |   |   |   |    |    |    |    |    |    |    |                     |

Note2: (\*2) Customer tag number can be engraved on standard stainless steel name plate. If extra tag plate is required, select "Yes".

Note3: (\*3) In case of tropical use, select stainless bolts and nuts.

Note4: (\*4) If other option is not necessary, 21st digit code is blank.  
In case of 21st digit code is blank, instruction manual attached.

Note5: (\*5) Not available for 10th digit code "B", "C".

Note6: (\*6) Available for 4th digit code "5", "S".

Note7: (\*7) Available for 6th digit code "3", "4".

Note8: (\*8) Available for 4th digit code "6", "8", "T", "W".

Note9: (\*9) Available for 4th digit code "6", "T".

## ACCESSORIES

**Oval flanges:** (Model FFP, refer to Data Sheet No. EDS6-128)  
Converts process connection to 1/2-14 NPT or to Rc1/2; in carbon steel or in 316 stainless steel.

**Hand held communicator:**  
(Model FXW, refer to Data Sheet No. EDS 8-47)

## ORDERING INFORMATION

When ordering this instrument, specify.

1. CODE SYMBOLS
2. Measuring range.
3. Output orientation (burnout direction) when abnormality is occurred in the transmitter.  
Hold / Overscale / Underscale  
Unless otherwise specified, output hold function is supplied.
4. Indication method (indicated value and unit) in case of the actual scale (code D, H, P, S on 9th digit).
5. Tag No. (up to 14 alphanumeric characters), if required.

OUTLINE DIAGRAM (Unit:mm)

< CODE SYMBOLS : FKA 

|   |   |
|---|---|
| 5 | 8 |
| 6 | 9 |
| 7 |   |

|  |  |  |  |
|--|--|--|--|
|  |  |  |  |
|--|--|--|--|

 5 >

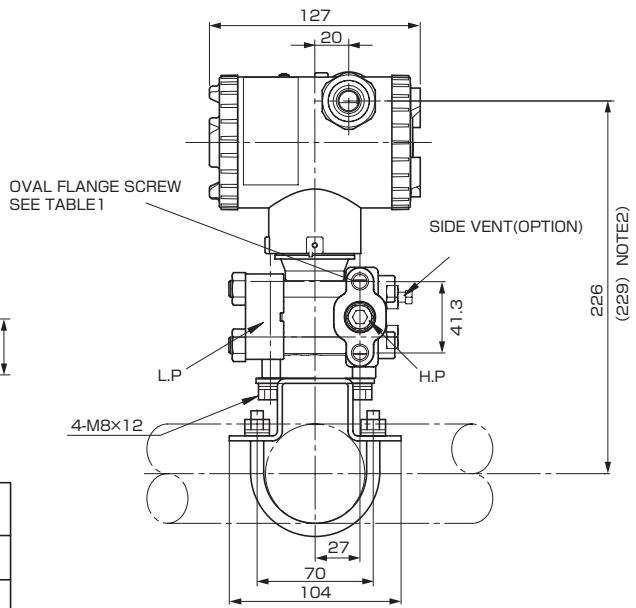
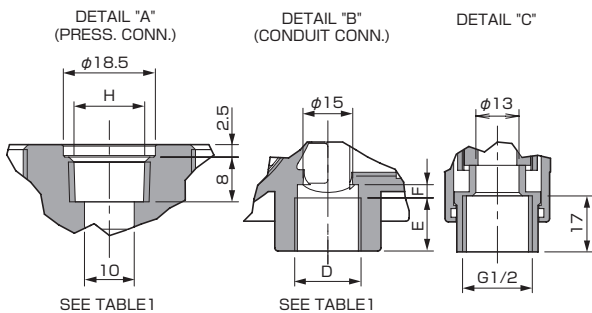
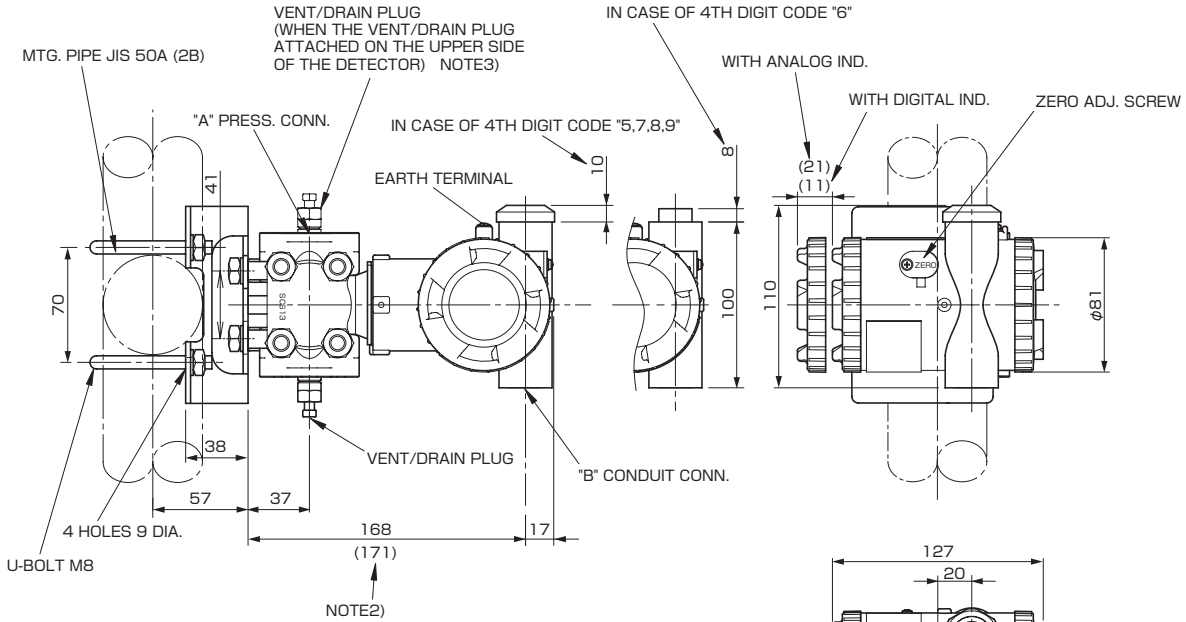

| 4th digit of the code symbols | Conduit conn. |      |     | Press. conn. | Oval frange screw        |
|-------------------------------|---------------|------|-----|--------------|--------------------------|
|                               | D             | E    | F   | H            |                          |
| 5                             | G 1/2         | 18   | 2   | Rc1/4        | 7/16-20UNF SCREW DEPTH15 |
| 6                             | 1/2-14NPT     | 16   | 4   | 1/4-18NPT    | 7/16-20UNF SCREW DEPTH15 |
| 7                             | Pg13.5        | 10.5 | 4.5 | 1/4-18NPT    | M10 SCREW DEPTH15        |
| 8                             | M20×1.5       | 16   | 4   | 1/4-18NPT    | M10 SCREW DEPTH15        |
| 9                             | Pg13.5        | 10.5 | 4.5 | 1/4-18NPT    | 7/16-20UNF SCREW DEPTH15 |

TABLE 1

CONNECTION DIAGRAM

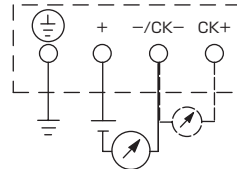

OPTION PARTS FOR FLAMEPROOF OF TIIS (JAPAN)

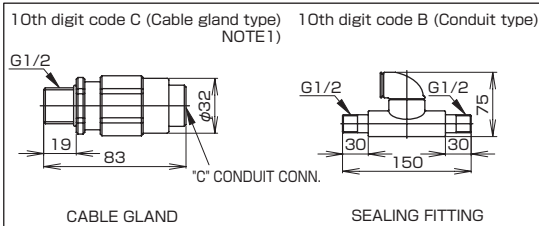

NOTE1) IN CASE OF 10TH CODE "C", Ø11 CABLE IS SUITBLE.  
 NOTE2) WHEN THE 7TH DIGIT OF THE CODE SYMBOLS "H,M,T"  
 NOTE3) THE PRESSURE CONNECTOR IS LOCATED ON THE DOWN SIDE SURFACE OF THE DETECTOR, WHEN THE VENT/DRAIN PLUG IS ATTACHED ON THE UPPER SIDE OF THE DETECTOR (WHEN THE 21ST DIGIT OF THE CODE SYMBOLS : C, P).



TABLE 2

| Authorities    | Intrinsic safety  |                |      |           |           |            |                |        |                |                |                |       |                |         |       |                |       |       |                |
|----------------|---|----------------|------|-----------|-----------|------------|----------------|--------|----------------|----------------|----------------|-------|----------------|---------|-------|----------------|-------|-------|----------------|
| ATEX           | <p>Ex II 1 G<br/>                     Ex ia IIC T5 Tamb = -40°C to +50°C<br/>                     Ex ia IIC T4 Tamb = -40°C to +70°C</p> <p>Entity Parameters:<br/>                     Ui=28V, li=94.3mA, Pi=0.66W,<br/>                     Ci=26nF (Without Arrester), Li=0.6mH (Without analog indicator),<br/>                     Ci=36nF (With Arrester), Li=0.7mH (With analog indicator)</p>   |                |      |           |           |            |                |        |                |                |                |       |                |         |       |                |       |       |                |
| Factory Mutual | <p>Class I II III<br/>                     Div.1 Groups A, B, C, D, E, F, G<br/>                     T4 Entity Type 4X</p> <table border="1"> <thead> <tr> <th>Model code</th> <th>Tamb</th> </tr> </thead> <tbody> <tr> <td>9th digit</td> <td></td> </tr> <tr> <td>A,B,D</td> <td>-40°C to +85°C</td> </tr> <tr> <td>L,P1,2</td> <td>-20°C to +80°C</td> </tr> <tr> <td>Q,S,4,5</td> <td>-20°C to +60°C</td> </tr> <tr> <td>E,F,H</td> <td>-40°C to +60°C</td> </tr> </tbody> </table> <p>Entity Parameters:<br/>                     Vmax=28V, Imax=94.3mA, Pi=0.66W,<br/>                     Ci=35.98nF, Li=0.694mH</p>  | Model code     | Tamb | 9th digit |           | A,B,D      | -40°C to +85°C | L,P1,2 | -20°C to +80°C | Q,S,4,5        | -20°C to +60°C | E,F,H | -40°C to +60°C |         |       |                |       |       |                |
| Model code     | Tamb  |                |      |           |           |            |                |        |                |                |                |       |                |         |       |                |       |       |                |
| 9th digit      |   |                |      |           |           |            |                |        |                |                |                |       |                |         |       |                |       |       |                |
| A,B,D          | -40°C to +85°C  |                |      |           |           |            |                |        |                |                |                |       |                |         |       |                |       |       |                |
| L,P1,2         | -20°C to +80°C  |                |      |           |           |            |                |        |                |                |                |       |                |         |       |                |       |       |                |
| Q,S,4,5        | -20°C to +60°C  |                |      |           |           |            |                |        |                |                |                |       |                |         |       |                |       |       |                |
| E,F,H          | -40°C to +60°C  |                |      |           |           |            |                |        |                |                |                |       |                |         |       |                |       |       |                |
| CSA            | <p>Class I<br/>                     Div.1 Groups A, B, C, D<br/>                     Class II<br/>                     Div.1 Groups E, F, G<br/>                     Class III<br/>                     Div.1</p> <p>Temp Code T5 Tamb max = +50°C<br/>                     Temp Code T4 Tamb max = +70°C</p> <p>Entity Parameters:<br/>                     Vmax=28V, Imax=94.3mA, Ci=25nF (Without Arrester),<br/>                     Ci=36nF (With Arrester), Li=0.6mH (Without analog meter),<br/>                     Li=0.7mH (With analog meter)</p>  |                |      |           |           |            |                |        |                |                |                |       |                |         |       |                |       |       |                |
| TIIS           | <p>Ex ia IIC T4<br/>                     Tamb max = +60°C</p> <p>Entity Parameters:<br/>                     Ui=28V, li=94.3mA, Pi=0.66W,<br/>                     Ci=38.4nF, Li=0.694mH</p>  |                |      |           |           |            |                |        |                |                |                |       |                |         |       |                |       |       |                |
| IECEx Scheme   | <p>Ex ia IIC T4<br/>                     Tamb = -40°C to +70°C<br/>                     Ex ia IIC T5<br/>                     Tamb = -40°C to +50°C</p> <p>Entity Parameters:<br/>                     Ui=28V, li=94.3mA, Pi=0.66W,<br/>                     Ci=26nF (Without Arrester), Li=0.6mH (Without analog indicator),<br/>                     Ci=36nF (With Arrester), Li=0.7mH (With analog indicator)</p>  |                |      |           |           |            |                |        |                |                |                |       |                |         |       |                |       |       |                |
| NEPSI          | <p>Ex ia IIC T4<br/>                     Ex d IIB+H<sub>2</sub> T6 / Ex ia IIC T4</p> <table border="1"> <thead> <tr> <th>Model code</th> <th colspan="2">Tamb</th> </tr> </thead> <tbody> <tr> <td>9th digit</td> <td>13th digit</td> <td></td> </tr> <tr> <td>A,B,D</td> <td>Y,G,N</td> <td>-40°C to +85°C</td> </tr> <tr> <td>L,P1,2</td> <td>Y,G,N</td> <td>-20°C to +80°C</td> </tr> <tr> <td>Q,S,4,5</td> <td>Y,G,N</td> <td>-20°C to +60°C</td> </tr> <tr> <td>E,F,H</td> <td>Y,G,N</td> <td>-40°C to +60°C</td> </tr> </tbody> </table> <p>Entity Parameters:<br/>                     Ui=42.4V, li=113mA, Pi=1W,<br/>                     Ci=35.98nF, Li=0.694mH</p> | Model code     | Tamb |           | 9th digit | 13th digit |                | A,B,D  | Y,G,N          | -40°C to +85°C | L,P1,2         | Y,G,N | -20°C to +80°C | Q,S,4,5 | Y,G,N | -20°C to +60°C | E,F,H | Y,G,N | -40°C to +60°C |
| Model code     | Tamb  |                |      |           |           |            |                |        |                |                |                |       |                |         |       |                |       |       |                |
| 9th digit      | 13th digit  |                |      |           |           |            |                |        |                |                |                |       |                |         |       |                |       |       |                |
| A,B,D          | Y,G,N   | -40°C to +85°C |      |           |           |            |                |        |                |                |                |       |                |         |       |                |       |       |                |
| L,P1,2         | Y,G,N   | -20°C to +80°C |      |           |           |            |                |        |                |                |                |       |                |         |       |                |       |       |                |
| Q,S,4,5        | Y,G,N   | -20°C to +60°C |      |           |           |            |                |        |                |                |                |       |                |         |       |                |       |       |                |
| E,F,H          | Y,G,N   | -40°C to +60°C |      |           |           |            |                |        |                |                |                |       |                |         |       |                |       |       |                |

| Authorities              | Flameproof  |            |      |           |  |       |                |        |                |         |                |       |                |
|--------------------------|---|------------|------|-----------|--|-------|----------------|--------|----------------|---------|----------------|-------|----------------|
| ATEX                     | <p>Ex II 2 GD<br/>                     Ex d IIC T6 IP66/67 T85°C<br/>                     Tamb = -40°C to +65°C<br/>                     Ex d IIC T5 IP66/67 T100°C<br/>                     Tamb = -40°C to +85°C</p>  |            |      |           |  |       |                |        |                |         |                |       |                |
| Factory Mutual           | <p>Class I<br/>                     Div.1 Groups B, C, D<br/>                     T6 Type 4X<br/>                     Class II III<br/>                     Div.1 Groups E, F, G<br/>                     T6 Type 4X<br/>                     Tamb max = +60°C</p>  |            |      |           |  |       |                |        |                |         |                |       |                |
| CSA                      | <p>Class I<br/>                     Div.1 Groups C, D<br/>                     Class II<br/>                     Div.1 Groups E, F, G<br/>                     Class III<br/>                     Div.1</p> <p>Note) "Seal Not Required" enclosure is allowed.</p>  |            |      |           |  |       |                |        |                |         |                |       |                |
| TIIS                     | <p>Ex do IIB+H<sub>2</sub> T4<br/>                     Tamb max = +60°C<br/>                     Maximum process temp. = +120°C</p>   |            |      |           |  |       |                |        |                |         |                |       |                |
| IECEx Scheme             | <p>Ex d IIC T5 IP66/67<br/>                     Tamb = -40°C to +85°C<br/>                     Ex d IIC T6 IP66/67<br/>                     Tamb = -40°C to +65°C</p>   |            |      |           |  |       |                |        |                |         |                |       |                |
| NEPSI                    | <p>Ex d IIB+H<sub>2</sub> T6<br/>                     Tamb = -40°C to +60°C</p>   |            |      |           |  |       |                |        |                |         |                |       |                |
| Authorities              | Type n<br>Nonincendive  |            |      |           |  |       |                |        |                |         |                |       |                |
| ATEX                     | <p>Ex II 3 GD<br/>                     EEx nL IIC T5 Tamb = -40°C to +50°C<br/>                     EEx nL IIC T4 Tamb = -40°C to +70°C</p> <p>Specific Parameters:<br/>                     Model without arrester:<br/>                     Ui=42.4V, li=113mA, Pi=1W,<br/>                     Ci=25.18nF, Li=0.694mH<br/>                     Model with arrester:<br/>                     Ui=32V, li=113mA, Pi=1W,<br/>                     Ci=35.98nF, Li=0.694mH</p> <p>EEx nAL IIC T5 Tamb = -40°C to +50°C<br/>                     EEx nAL IIC T4 Tamb = -40°C to +70°C</p> <p>Specific Parameters:<br/>                     Model without arrester:<br/>                     Umax=42.4V, Imax=113mA, Pmax=1W<br/>                     Model with arrester:<br/>                     Umax=32V, Imax=113mA, Pmax=1W</p> |            |      |           |  |       |                |        |                |         |                |       |                |
| Factory Mutual (pending) | <p>Class I II III<br/>                     Div.2 Groups A, B, C, D, F, G<br/>                     T4 Entity Type 4X</p> <table border="1"> <thead> <tr> <th>Model code</th> <th>Tamb</th> </tr> </thead> <tbody> <tr> <td>9th digit</td> <td></td> </tr> <tr> <td>A,B,D</td> <td>-40°C to +85°C</td> </tr> <tr> <td>L,P1,2</td> <td>-20°C to +80°C</td> </tr> <tr> <td>Q,S,4,5</td> <td>-20°C to +60°C</td> </tr> <tr> <td>E,F,H</td> <td>-40°C to +60°C</td> </tr> </tbody> </table>   | Model code | Tamb | 9th digit |  | A,B,D | -40°C to +85°C | L,P1,2 | -20°C to +80°C | Q,S,4,5 | -20°C to +60°C | E,F,H | -40°C to +60°C |
| Model code               | Tamb  |            |      |           |  |       |                |        |                |         |                |       |                |
| 9th digit                |   |            |      |           |  |       |                |        |                |         |                |       |                |
| A,B,D                    | -40°C to +85°C  |            |      |           |  |       |                |        |                |         |                |       |                |
| L,P1,2                   | -20°C to +80°C  |            |      |           |  |       |                |        |                |         |                |       |                |
| Q,S,4,5                  | -20°C to +60°C  |            |      |           |  |       |                |        |                |         |                |       |                |
| E,F,H                    | -40°C to +60°C  |            |      |           |  |       |                |        |                |         |                |       |                |
| CSA                      | <p>Class I<br/>                     Div.2 Groups A, B, C, D<br/>                     Class II<br/>                     Div.2 Groups E, F, G<br/>                     Class III<br/>                     Div.2</p> <p>Temp Code T5 Tamb max = +50°C<br/>                     Temp Code T4 Tamb max = +70°C</p> <p>Entity Parameters:<br/>                     Vmax=28V, Ci=25.18nF (Without Arrester),<br/>                     Ci=35.98nF (With Arrester), Li=0.694mH</p>   |            |      |           |  |       |                |        |                |         |                |       |                |

**⚠ Caution on Safety**

\*Before using this product, be sure to read its instruction manual in advance.

**Fuji Electric Systems Co., Ltd.**

**International Sales Div.1  
Sales Group**

Gate City Ohsaki, East Tower, 11-2, Osaki 1-chome,  
 Shinagawa-ku, Tokyo 141-0032, Japan  
<http://www.fesys.co.jp/eng>  
 Phone: 81-3-5435-7280, 7281 Fax: 81-3-5435-7425  
<http://www.fic-net.jp/eng>