

PRESSURE TRANSMITTER

Hydroseal® Diaphragm Version

DATA SHEET

FKG...5

FEATURES

1. Unique hydroseal diaphragm

Permeation of hydrogen into the detecting unit through seal diaphragm can be suppressed thanks to the unique seal diaphragm (double coating) which employs coating of gold and ceramic.

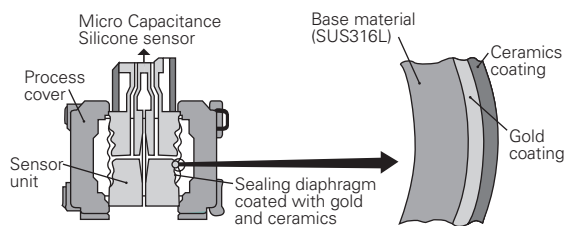

2. High accuracy

±0.15% accuracy for all calibrated spans is the standard feature for pressure transmitter covering 50 to 10000kPa (or 0.5 to 100 kgf/cm²). Fuji's Micro-capacitance silicon sensor assures this feature.

3. Minimum environment influence

Fuji's patented "Advanced Floating Cell" design which protects the pressure sensor against changes in temperature and overpressure substantially reduces total measurement error in actual field applications.

4. Fuji/HART® bilingual communications protocol

FCX-AIII series transmitter offers bilingual communications to speak both Fuji proprietary protocol and HART®. Any HART® compatible devices can communicate with FCX-AIII.

5. Application flexibility

Various options that render the FCX-AIII series suitable for almost any process applications include.

- Full range of hazardous location approvals
- 5-digit LCD meter with engineering unit
- Stainless steel electronics housing
- Built-in RFI filter and lightning arrester

6. Burnout current flexibility (Under Scale: 3.2 to 4.0mA, Over Scale: 20.0 to 22.5mA)

Burnout signal level is adjustable using Model FXW hand Held Communicator (HHC) to comply with NAMUR NE43.

7. Dry calibration without reference pressure

Thanks to the best combination of unique construction of mechanical parts (Sensor unit) and high performance electronics circuit (Electronics unit), reliability of dry calibration without reference pressure is at equal level as wet calibration.

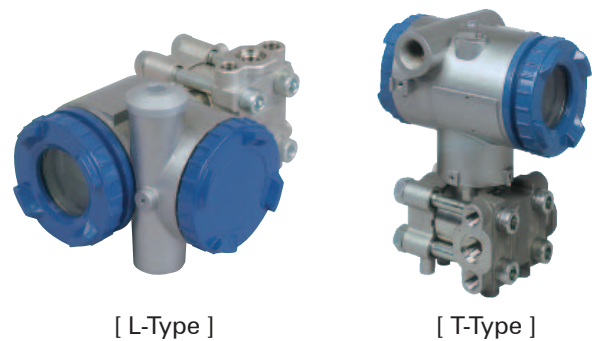

SPECIFICATIONS

Functional specifications

Service: Liquid, gas, or vapour

Span, range and overrange limit:

Type	Static pressure [MPa] (kgf/cm ²)	Span limit [kPa] (bar)		Range limit [kPa] (bar)		Over range limit [MPa] (bar)
		Min.	Max.	Lower limit	Upper limit	
FKG□07	-0.1 to 0.5 (-1 to 5)	50 (0.5)	500 (5)	-100 (-1)	500 (5)	1.5 (15)
FKG□08	-0.1 to 3 (-1 to 30)	300 (3)	3000 (30)	-100 (-1)	3000 (30)	9 (90)
FKG□09	-0.1 to 10 (-1 to 100)	1000 (10)	10000 (100)	-100 (-1)	10000 (100)	15 (150)

Remark: To minimize environmental influence, span should be greater than 1/40 of the max. span in most applications.

- Lower range limit (vacuum limit) ;
Silicone fill sensor: See Fig. 1
Fluorinated fill sensor: 66kPa abs (500mmHg abs) at below 60°C
- Conversion factors to different units;
1 MPa=10³ kPa=10bar=10.19716kgf/cm²=145.0377psi
1kPa=10mbar=101.9716mmH₂O=4.01463inH₂O

Output signal: 4 to 20mA DC with digital signal superimposed on the 4 to 20mA signal.

Power supply: Transmitter operates on 10.5V to 45V DC at transmitter terminals.
10.5V to 32V DC for the units with optional arrester.

Load limitations: see figure below

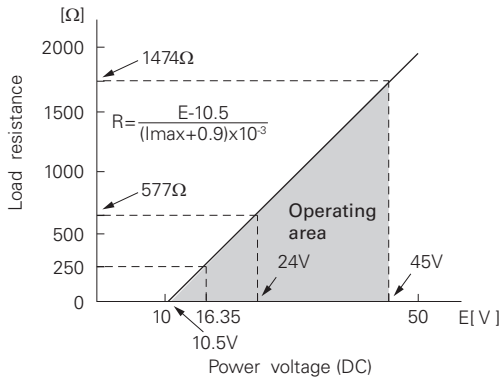

Note: For communication with HHC⁽¹⁾ (Model: FXW), min. of 250Ω required.

Hazardous locations: (Under an application) See TABLE 2
Zero/span adjustment:

Zero and span are adjustable from the HHC⁽¹⁾. Zero and span are also adjustable externally from the adjustment screw.

Damping: Adjustable from HHC or local configurator unit with LCD display. The time constant is adjustable between 0.06 to 32 seconds.

Zero elevation/suppression: Zero can be elevated or suppressed within the specified range limit of each sensor model.

Normal/reverse action: Selectable from HHC⁽¹⁾.

Indication: Analog indicator or 5-digit LCD meter, as specified.

Burnout direction: Selectable from HHC⁽¹⁾. If self-diagnostic detect transmitter failure, the analog signal will be driven to either "Output Hold", "Output Overscale" or "Output Underscale" modes.

"Output Hold": Output signal is hold as the value just before failure happens.

"Output Overscale": Adjustable within the range 20.0mA to 22.5mA from HHC⁽¹⁾

"Output Underscale": Adjustable within the range 3.2mA to 4.0mA from HHC⁽¹⁾

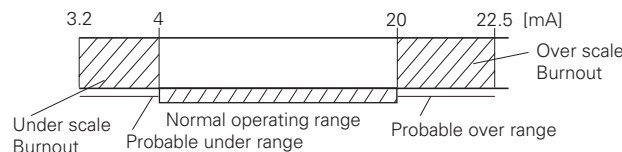

Loop-check output: Transmitter can be configured to provide constant signal 3.2mA through 22.5mA by HHC.

Temperature limit:
 Ambient: -40 to +85°C
 (-20 to +80°C for LCD indicator)
 (-40 to +60°C for arrester option)
 (-10 to +60°C for fluorinated oil fill transmitter)
 For explosionproof units (flameproof or intrinsic safety), ambient temperature must be within the limits specified by each standard.
 Process: -40 to +100°C for silicone fill sensor
 -20 to +80°C for fluorinated oil fill sensor
 Storage: -40 to +90°C

Humidity limit: 0 to 100% RH
Communication: With HHC⁽¹⁾ (Model FXW, consult Data Sheet No. EDS8-47), following items can be remotely displayed or configured.

Note: HHC's version must be higher than 7.0 (or FXW □□□□1-□4), for FCX-AIII.

Local configurator with LCD display (option): Local configurator with 3 push button and LCD display can support following items.

Items	By communication with FXW		By local configurator (with 3 push button)	
	Display	Set	Display	Set
Tag No.	✓	✓	✓	✓
Model No.	✓	✓	✓	✓
Serial No. & Software Version	✓	—	✓	—
Engineering unit	✓	✓	✓	✓
Range limit	✓	—	✓	—
Measuring range	✓	✓	✓	✓
Damping	✓	✓	✓	✓
Output mode	✓	—	✓	—
Burnout direction	✓	✓	✓	✓
Calibration	✓	✓	✓	✓
Output adjust	—	✓	—	✓
Data	✓	—	✓	—
Self diagnoses	✓	—	✓	—
Printer (In case of FXW with printer option)	✓	—	—	—
External switch lock	✓	✓	✓	✓
Transmitter display	✓	✓	✓	✓
Linearize	✓	✓	—	—
Rerange	✓	✓	✓	✓
Saturate current	✓	✓	✓	✓
Write protect	✓	✓	✓	✓
History				
- Calibration history	✓	✓	✓	✓
- Ambient temperature history	✓	—	✓	—

EMC Conformity: EN61326-1: 2006 CE

Performance specifications

Reference conditions, silicone oil fill, 316SS isolating diaphragms, 4 to 20mA analog output in linear mode.

Accuracy rating: (including linearity, hysteresis, and repeatability)

Stability: ±0.15% of upper range limit (URL) for 10 years.

(Note) (1) HHC: Hand Held Communicator

Temperature effect:

Effects per 28°C change between the limits of -40°C and +85°C

Zero shift: $\pm(0.1+0.075 \frac{\text{URL}}{\text{span}})\% / 28^\circ\text{C}$

Total effect: $\pm(0.125+0.075 \frac{\text{URL}}{\text{span}})\% / 28^\circ\text{C}$

Overrange effect: Zero shift; 0.4% of URL for any overrange to maximum limit

Supply voltage effect:

Less than 0.005% of calibrated span per 1V

RFI effect:

Less than 0.2% of URL for the frequencies of 20 to 1000MHz and field strength 30 V/m when electronics covers on. (Classification: 2-abc: 0.2% span per SAMA PMC 33.1)

Update period: 60 msec

Step response: Time constant: 0.08s

Dead time: 0.12s
(without electrical damping)

Mounting position effect:

Zero shift, less than 0.1kPa (1m bar) for a 10° tilt in any plane.

No effect on span. This error can be corrected by adjusting Zero.

Dielectric strength:

500V AC, 50/60Hz 1 min., between circuit and earth.

Insulation resistance:

More than 100MΩ at 500V DC.

Internal resistance for external field indicator:

12Ω or less

Physical specifications**Electrical connections:**

G1/2, 1/2-14 NPT, Pg13.5, or M20 × 1.5 conduit, as specified.

Process connections:

1/4-18 NPT or Rc1/4 on 54mm centers, as specified.

Meet DIN 19213

Process-wetted parts material:

Material code	Process cover	Wetted sensor body		Vent/drain
		Diaphragm	Other wetted parts	
C	316 stainless steel (*1)	316L stainless steel (*2)	316 stainless steel	316/316L stainless steel

Notes: (*1) SCS14A per JIS G 5121 (equivalent CF8M per ASTM A351/A351M)

(*2) The diaphragm face is coated with gold and ceramic.

Remark: Sensor O-rings : Viton O-ring and teflon gasket selectable

Non-wetted parts material:

Electronics housing: Low copper die-cast aluminum alloy finished with epoxy/polyurethane double coating (standard), or 316 stainless steel (SCS14A per JIS G5121), as specified.

Bolts and nuts: Cr-Mo alloy (standard), or 304 stainless steel.

Fill fluid: Silicone oil (standard) or fluorinated oil

Mounting bracket: 304 stainless steel

Environmental protection:

IEC IP67 and NEMA 6/6P

Mounting:

On 60.5mm (JIS 50A) pipe using mounting bracket, direct wall mounting, or direct process mounting.

Mass {weight}:

Transmitter approximately 3.4kg without options.

Add; 0.5kg for mounting bracket

4.5kg for stainless steel housing option

Optional features**Indicator:**

A plug-in analog indicator (2.5% accuracy).

An optional 5-digit LCD meter with engineering is also available.

Local configurator with LCD display:

An optional 5 digits LCD meter with 3 push buttons can support items as using communication with FXW.

Arrester:

A built-in arrester protects the electronics from lightning surges.

Lightning surge immunity : 4kV (1.2 × 50μs)

Oxygen service:

Special cleaning procedures are followed throughout the process to maintain all process wetted parts oil-free.

The fill fluid is fluorinated oil.

Chlorine service:

The fill fluid is fluorinated oil.

Degreasing:

Process-wetted parts are cleaned, but the fill fluid is standard silicone oil. Not for use on oxygen or chlorine measurement.

NACE specification:

Metallic materials for all pressure boundary parts comply with NACE MR-01-75. ASTM B7M or L7M bolts and 2HM nuts (Class II) are standard.

Vacuum service:

Special silicone oil and filling procedure are applied.

See Fig.1.

Optional tag plate:

An extra stainless steel tag with customer tag data is wired to the transmitter.

Coating of cell:

Cell's surface is finished with epoxy/polyurethane double coating. Specify if environment is extremely corrosive.

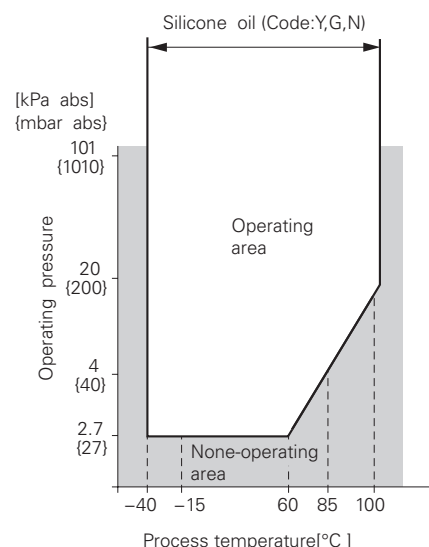

Fig. 1 Relation between process temperature and operating pressure

CODE SYMBOLS

Digit	Description	Note	1	2	3	4	5	6	7	8	9	10	11	12	13	14	15	21	← Digit No. of code
4	<Connections>		F	K	G	0	5												
	Process connection	Oval flange screw	Conduit connection	Case type															
	Rc1/4	7/16-20UNF	G1/2	T type	5														
	1/4-18NPT	7/16-20UNF	1/2-14NPT	T type	6														
	1/4-18NPT	M10	Pg13.5	T type	7														
	1/4-18NPT	M10	M20×1.5	T type	8														
	1/4-18NPT	7/16-20UNF	Pg13.5	T type	9														
	Rc1/4	7/16-20UNF	G1/2	L type	S														
	1/4-18NPT	7/16-20UNF	1/2-14NPT	L type	T														
	1/4-18NPT	M10	Pg13.5	L type	V														
1/4-18NPT	M10	M20×1.5	L type	W															
1/4-18NPT	7/16-20UNF	Pg13.5	L type	X															
6																			
	50	500 (or 0.5...5)						7											
	300	3000 (or 3...30)						8											
	1000	10000 (or 10...100)						9											
7	<Material>																		
	Process cover	Wetted cell body Diaphragm	Other wetted parts																
	316 Stainless Steel	316 Stainless Steel (*1)	316 Stainless Steel	Note 1															
9	<Indicator and arrester>																		
	Indicator	Arrester																	
	None	None																	
	Analog, 0 to 100% linear scale	None																	
	Analog, custom scale	None																	
	None	Yes																	
	Analog, 0 to 100% linear scale	Yes																	
	Analog, custom scale	Yes																	
	Digital, 0 to 100% linear scale	None																	
	Digital, custom scale	None																	
	Digital, 0 to 100% linear scale	Yes																	
	Digital, custom scale	Yes																	
	Digital, 0 to 100% linear scale (Local configurator unit with LCD display)	None																	
Digital, custom scale (Local configurator unit with LCD display)	None																		
Digital, 0 to 100% linear scale (Local configurator unit with LCD display)	Yes																		
Digital, custom scale (Local configurator unit with LCD display)	Yes																		
10	<Approvals for hazardous locations>																		
	None (for ordinary locations)																		
	TIIS, Flameproof (Conduit seal) (*5)	Note 5																	
	TIIS, Flameproof (Cable gland seal) (*5)	Note 5																	
	TIIS, Intrinsic safety																		
	FM, Flameproof (or explosionproof) (*8)	Note 8																	
	FM, Intrinsic safety and nonincentive																		
	FM Combined of flameproof and intrinsic safety (*8)	Note 8																	
	ATEX Flameproof (*7)	Note 7																	
	ATEX Intrinsic safety																		
	ATEX Type n																		
	ATEX Combined of flameproof and intrinsic safety (*7)	Note 7																	
	IECEX Scheme, Flameproof (*7)	Note 7																	
	IECEX Scheme, Intrinsic safety																		
	CSA, Flameproof (or explosionproof) (*8)	Note 8																	
CSA, Intrinsic safety and nonincentive																			
NEPSI, Flameproof (or explosionproof)																			
NEPSI, Intrinsic safety																			
NEPSI, Combined of flameproof and intrinsic safety																			
11	<Vent/ drain and mounting bracket>																		
	Vent/drain	Mounting bracket	Process connection																
	Standard	None	Standard																
	Standard	Yes, SUS304	Standard																
	Standard	Yes, SUS316	Standard																
	Side	None	Standard																
Side	Yes, SUS304	Standard																	
Side	Yes, SUS316	Standard																	

Note 1: (*1) The diaphragm face is coated with gold and ceramic.

Digit	Description	Note	1	2	3	4	5	6	7	8	9	10	11	12	13	14	15	21	← Digit No. of code
12	<Options> Extra SS tag plate Stainless steel elec. housing Coating of cell		F	K	G	0	5												
	None } Yes } (*2)	None None None													Y B				
	None } Yes } (*9)	None None Yes Yes													M N P Q				
13	<Special applications and fill fluid> Treatment Fill fluid																		
	Standard Silicone oil														Y W G				
	Standard Fluorinated oil																		
	Degreasing Silicone oil																		
	Oxygen service Fluorinated oil															A			
	NACE specification Silicone oil (Not available for 15th digit code "A", "B")															N			
14	<Sensor O-ring / Gasket> Teflon (gasket)																		
15	<Bolt/nut> (*4) <Vent Drain plug type>	Note 4																	
	Cr-Mo alloy hexagon socket head cap screw/carbon steel nut Standard																		A
	Cr-Mo alloy hexagon bolt/nut Standard																		B
	NACE bolt/nut (ASTM A193 B7M/A194 2HM) Standard																		C
	NACE bolt/nut (ASTM A320 L7M/A194 2HM) Standard																		D
	304 stainless steel bolt/304 stainless steel nut Standard																		E
	316 stainless steel bolt/316 stainless steel nut Standard																		U
21	<Other options> (*3) Instruction manual unattached	Note 3																	
	Opposite Vent/Drain Plug Position Instruction manual attached																		L
	Opposite Vent/Drain Plug Position Instruction manual unattached																		C P

Note2: (*2) Customer tag number can be engraved on standard stainless steel name plate. If extra tag plate is required, select "Yes".

Note3: (*3) If other option is not necessary, 21st digit code is blank. In case of 21st digit code is blank, instruction manual attached.

Note4: (*4) In case of tropical use, select stainless bolts and nuts.

Note5: (*5) Available for 4th digit code "5", "S".

Note7: (*7) Available for 4th digit code "6", "8", "T", "W".

Note8: (*8) Available for 4th digit code "6", "T".

Note9: (*9) Not available for 10th digit code "B", "C".

ACCESSORIES

Oval flanges: (Model FFP, refer to Data Sheet No. EDS6-128)
Converts process connection to 1/2-14 NPT or to Rc1/2; in carbon steel or in 316 stainless steel.

Hand-held communicator: (Model FXW, refer to Data Sheet No. EDS8-47)

ORDERING INFORMATION

When ordering this instrument, specify.

1. CODE SYMBOLS
2. Measuring range
3. Output orientation (burnout direction) when abnormality is occurred in the transmitter.
Hold / Underscale / Overscale
Unless otherwise specified, output hold function is supplied.
4. Indication method (indicated value and unit) in case of the actual scale (code D,H,P,S on 9th digit).
5. Tag No. (up to 14 alphanumeric characters), if required.

OUTLINE DIAGRAM (Unit:mm)

< CODE SYMBOLS : FKG

S	W
T	X
V	

 0

C	5
---	---

 >

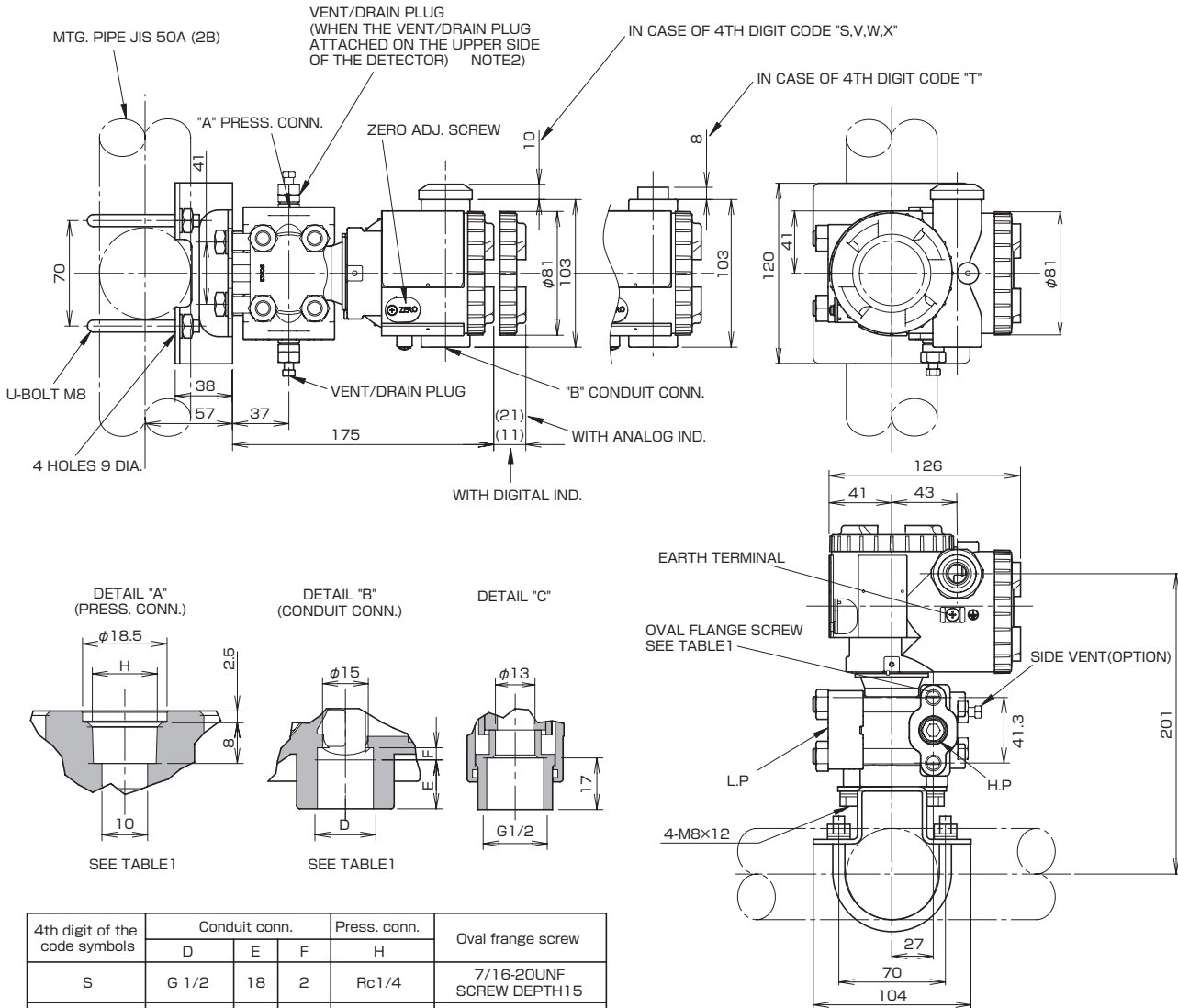

4th digit of the code symbols	Conduit conn.			Press. conn.	Oval frange screw
	D	E	F	H	
S	G 1/2	18	2	Rc1/4	7/16-20UNF SCREW DEPTH15
T	1/2-14NPT	16	4	1/4-18NPT	7/16-20UNF SCREW DEPTH15
V	Pg13.5	10.5	4.5	1/4-18NPT	M10 SCREW DEPTH15
W	M20x1.5	16	4	1/4-18NPT	M10 SCREW DEPTH15
X	Pg13.5	10.5	4.5	1/4-18NPT	7/16-20UNF SCREW DEPTH15

TABLE 1

CONNECTION DIAGRAM

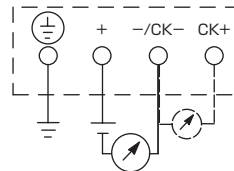

OPTION PARTS FOR FLAMEPROOF OF TIIS (JAPAN)

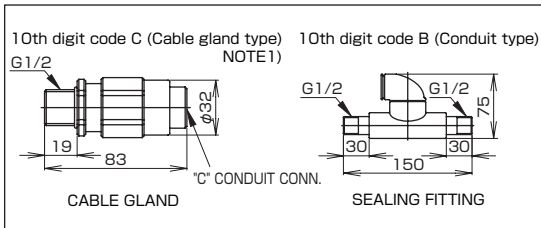

NOTE1) IN CASE OF 10TH CODE "C", φ11 CABLE IS SUITBLE.
 NOTE2) THE PRESSURE CONNECTOR IS LOCATED ON THE DOWN SIDE SURFACE OF THE DETECTOR, WHEN THE VENT/ DRAIN PLUG IS ATTACHED ON THE UPPER SIDE OF THE DETECTOR (WHEN THE 21ST DIGIT OF THE CODE SYMBOLS : C, P).

TABLE 2

Authorities	Intrinsic safety																					
ATEX	Ex II 1 G Ex ia IIC T5 Tamb = -40°C to +50°C Ex ia IIC T4 Tamb = -40°C to +70°C Entity Parameters: Ui=28V, li=94.3mA, Pi=0.66W, Ci=26nF (Without Arrester), Li=0.6mH (Without analog indicator), Ci=36nF (With Arrester), Li=0.7mH (With analog indicator)																					
Factory Mutual	Class I II III Div.1 Groups A, B, C, D, E, F, G T4 Entity Type 4X <table border="1"> <thead> <tr> <th colspan="2">Model code</th> <th>Tamb</th> </tr> <tr> <th>9th digit</th> <th>13th digit</th> <th></th> </tr> </thead> <tbody> <tr> <td>A,B,D</td> <td>Y,G,N</td> <td>-40°C to +85°C</td> </tr> <tr> <td>L,P1,2</td> <td>Y,G,N</td> <td>-20°C to +80°C</td> </tr> <tr> <td>Q,S,4,5</td> <td>Y,G,N</td> <td>-20°C to +60°C</td> </tr> <tr> <td>E,F,H</td> <td>Y,G,N</td> <td>-40°C to +60°C</td> </tr> <tr> <td>-</td> <td>W,A</td> <td>-10°C to +60°C</td> </tr> </tbody> </table> Entity Parameters: Vmax=28V, Imax=94.3mA, Pi=0.66W, Ci=35.98nF, Li=0.694mH	Model code		Tamb	9th digit	13th digit		A,B,D	Y,G,N	-40°C to +85°C	L,P1,2	Y,G,N	-20°C to +80°C	Q,S,4,5	Y,G,N	-20°C to +60°C	E,F,H	Y,G,N	-40°C to +60°C	-	W,A	-10°C to +60°C
Model code		Tamb																				
9th digit	13th digit																					
A,B,D	Y,G,N	-40°C to +85°C																				
L,P1,2	Y,G,N	-20°C to +80°C																				
Q,S,4,5	Y,G,N	-20°C to +60°C																				
E,F,H	Y,G,N	-40°C to +60°C																				
-	W,A	-10°C to +60°C																				
CSA	Class I Div.1 Groups A, B, C, D Class II Div.1 Groups E, F, G Class III Div.1 Temp Code T5 Tamb max = +50°C Temp Code T4 Tamb max = +70°C Entity Parameters: Vmax=28V, Imax=94.3mA, Ci=25nF (Without Arrester), Ci=36nF (With Arrester), Li=0.6mH (Without analog meter), Li=0.7mH (With analog meter)																					
TIIS	Ex ia IIC T4 Tamb max = +60°C Entity Parameters: Ui=28V, li=94.3mA, Pi=0.66W, Ci=38.4nF, Li=0.694mH																					
IECEx Scheme	Ex ia IIC T4 Tamb = -40°C to +70°C Ex ia IIC T5 Tamb = -40°C to +50°C Entity Parameters: Ui=28V, li=94.3mA, Pi=0.66W, Ci=26nF (Without Arrester), Li=0.6mH (Without analog indicator), Ci=36nF (With Arrester), Li=0.7mH (With analog indicator)																					
NEPSI	Ex ia IIC T4 Ex d IIB+H ₂ T6 / Ex ia IIC T4 <table border="1"> <thead> <tr> <th colspan="2">Model code</th> <th>Tamb</th> </tr> <tr> <th>9th digit</th> <th>13th digit</th> <th></th> </tr> </thead> <tbody> <tr> <td>A,B,D</td> <td>Y,G,N</td> <td>-40°C to +85°C</td> </tr> <tr> <td>L,P1,2</td> <td>Y,G,N</td> <td>-20°C to +80°C</td> </tr> <tr> <td>Q,S,4,5</td> <td>Y,G,N</td> <td>-20°C to +60°C</td> </tr> <tr> <td>E,F,H</td> <td>Y,G,N</td> <td>-40°C to +60°C</td> </tr> <tr> <td>-</td> <td>W,A</td> <td>-10°C to +60°C</td> </tr> </tbody> </table> Entity Parameters: Ui=42.4V, li=113mA, Pi=1W, Ci=35.98nF, Li=0.694mH	Model code		Tamb	9th digit	13th digit		A,B,D	Y,G,N	-40°C to +85°C	L,P1,2	Y,G,N	-20°C to +80°C	Q,S,4,5	Y,G,N	-20°C to +60°C	E,F,H	Y,G,N	-40°C to +60°C	-	W,A	-10°C to +60°C
Model code		Tamb																				
9th digit	13th digit																					
A,B,D	Y,G,N	-40°C to +85°C																				
L,P1,2	Y,G,N	-20°C to +80°C																				
Q,S,4,5	Y,G,N	-20°C to +60°C																				
E,F,H	Y,G,N	-40°C to +60°C																				
-	W,A	-10°C to +60°C																				

Authorities	Flameproof																					
ATEX	Ex II 2 GD Ex d IIC T6 IP66/67 T85°C Tamb = -40°C to +65°C Ex d IIC T5 IP66/67 T100°C Tamb = -40°C to +85°C																					
Factory Mutual	Class I Div.1 Groups B, C, D T6 Type 4X Class II III Div.1 Groups E, F, G T6 Type 4X Tamb max = +60°C																					
CSA	Class I Div.1 Groups C, D Class II Div.1 Groups E, F, G Class III Div.1 Note) "Seal Not Required" enclosure is allowed.																					
TIIS	Ex do IIB+H ₂ T4 Tamb max = +60°C Maximum process temp. = +120°C																					
IECEx Scheme	Ex d IIC T5 IP66/67 Tamb = -40°C to +85°C Ex d IIC T6 IP66/67 Tamb = -40°C to +65°C																					
NEPSI	Ex d IIB+H ₂ T6 Tamb = -40°C to +60°C																					
Authorities	Type n Nonincendive																					
ATEX	Ex II 3 GD EEx nL IIC T5 Tamb = -40°C to +50°C EEx nL IIC T4 Tamb = -40°C to +70°C Specific Parameters: Model without arrester: Ui=42.4V, li=113mA, Pi=1W, Ci=25.18nF, Li=0.694mH Model with arrester: Ui=32V, li=113mA, Pi=1W, Ci=35.98nF, Li=0.694mH EEx nAL IIC T5 Tamb = -40°C to +50°C EEx nAL IIC T4 Tamb = -40°C to +70°C Specific Parameters: Model without arrester: Umax=42.4V, Imax=113mA, Pmax=1W Model with arrester: Umax=32V, Imax=113mA, Pmax=1W																					
Factory Mutual (pending)	Class I II III Div.2 Groups A, B, C, D, F, G T4 Entity Type 4X <table border="1"> <thead> <tr> <th colspan="2">Model code</th> <th>Tamb</th> </tr> <tr> <th>9th digit</th> <th>13th digit</th> <th></th> </tr> </thead> <tbody> <tr> <td>A,B,D</td> <td>Y,G,N</td> <td>-40°C to +85°C</td> </tr> <tr> <td>L,P1,2</td> <td>Y,G,N</td> <td>-20°C to +80°C</td> </tr> <tr> <td>Q,S,4,5</td> <td>Y,G,N</td> <td>-20°C to +60°C</td> </tr> <tr> <td>E,F,H</td> <td>Y,G,N</td> <td>-40°C to +60°C</td> </tr> <tr> <td>-</td> <td>W,A</td> <td>-10°C to +60°C</td> </tr> </tbody> </table>	Model code		Tamb	9th digit	13th digit		A,B,D	Y,G,N	-40°C to +85°C	L,P1,2	Y,G,N	-20°C to +80°C	Q,S,4,5	Y,G,N	-20°C to +60°C	E,F,H	Y,G,N	-40°C to +60°C	-	W,A	-10°C to +60°C
Model code		Tamb																				
9th digit	13th digit																					
A,B,D	Y,G,N	-40°C to +85°C																				
L,P1,2	Y,G,N	-20°C to +80°C																				
Q,S,4,5	Y,G,N	-20°C to +60°C																				
E,F,H	Y,G,N	-40°C to +60°C																				
-	W,A	-10°C to +60°C																				
CSA	Class I Div.2 Groups A, B, C, D Class II Div.2 Groups E, F, G Class III Div.2 Temp Code T5 Tamb max = +50°C Temp Code T4 Tamb max = +70°C Entity Parameters: Vmax=28V, Ci=25.18nF (Without Arrester), Ci=35.98nF (With Arrester), Li=0.694mH																					

⚠ Caution on Safety

*Before using this product, be sure to read its instruction manual in advance.

Fuji Electric Systems Co., Ltd.

**International Sales Div.1
Sales Group**

Gate City Ohsaki, East Tower, 11-2, Osaki 1-chome,
Shinagawa-ku, Tokyo 141-0032, Japan
<http://www.fesys.co.jp/eng>
Phone: 81-3-5435-7280, 7281 Fax: 81-3-5435-7425
<http://www.fic-net.jp/eng>