

REMOTE SEAL TYPE PRESSURE TRANSMITTER <SANITARY TYPE>

DATA SHEET

FKB...5

The FCX-AIII pressure transmitter accurately measures gauge pressure and transmits a proportional 4 to 20mA signal. The transmitter utilizes a unique micromachined capacitance silicon sensor with state-of-the-art microprocessor technology to provide exceptional performance and functionality. Totally welded construction of the seals assures excellent reliability in high temperature and highly corrosive process conditions.

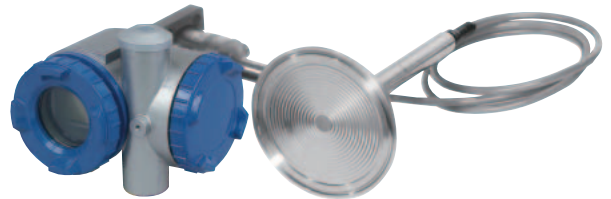

FEATURES

- High accuracy**
0.2% accuracy for all calibrated spans is a standard feature for all GP models covering 1.3kPa {0.013bar} range to 50000kPa {500bar} high pressure range. 0.1% accuracy is available as option. Fuji's micro-capacitance silicon sensor assures this accuracy for all elevated or suppressed calibration ranges without additional adjustment.
- Minimum environmental influence**
The "Advanced Floating Cell" design which protects the pressure sensor against changes in temperature, and overpressure substantially reduces total measurement error in actual field applications.
- Fuji/HART® bilingual communications protocol**
FCX-AIII series transmitter offers bilingual communications to speak both Fuji proprietary protocol and HART®. Any HART® compatible devices can communicate with FCX-AIII.
- Application flexibility**
Various options that render the FCX-AIII suitable for almost any process applications include:
 - Full range of hazardous area approvals
 - Built-in RFI filter and lightning arrester
 - 5-digit LCD meter with engineering unit
 - Stainless steel electronics housing
 - Wide selection of materials
 - High temperature, high vacuum seals
- Burnout current flexibility (Under Scale: 3.2 to 4.0mA, Over Scale: 20.0 to 22.5mA)**
Burnout signal level is adjustable using Model FXW Hand Held Communicator (HHC) to comply with NAMUR NE43.
- Dry calibration without reference pressure**
Thanks to the best combination of unique construction of mechanical parts (Sensor unit) and high performance electronics circuit (Electronics unit), reliability of dry calibration without reference pressure is at equal level as wet calibration.

SPECIFICATIONS

Functional specifications

Service: Liquid, gas, or vapour
Span, range, and overrange limit:

Type	Span limit [kPa]{bar}		Range limit [kPa]{bar}	Overrange limit [MPa] {bar}
	Min.	Max.		
FKB□□1	1.3 {0.013}	130 {1.3}	-130 to +130 {-1.3 to +1.3}	1 {10}
FKB□□2	5 {0.05}	500 {5}	-100 to +500 {-1 to +5}	1.5 {15}
FKB□□3	30 {0.3}	3000 {30}	-100 to +3000 {-1 to +30}	4.5 {45}

Remark: To minimize environmental influence, span should be greater than 1/40 of the max. span in most applications.

- Lower range limit (vacuum limit) ;
Silicone fill sensor: See Fig. 1
- Conversion factors to different units;
1MPa=10³kPa=10bar=10.19716kgf/cm²=145.0377psi
1kPa=10mbar=101.9716mmH₂O=4.01463inH₂O
- Output signal:** 4 to 20mA DC with digital signal superimposed on the 4 to 20mA signal.
- Power supply:** Transmitter operates on 10.5V to 45V DC at transmitter terminals.
10.5V to 32V DC for the units with optional arrester.

Load limitations: see figure below

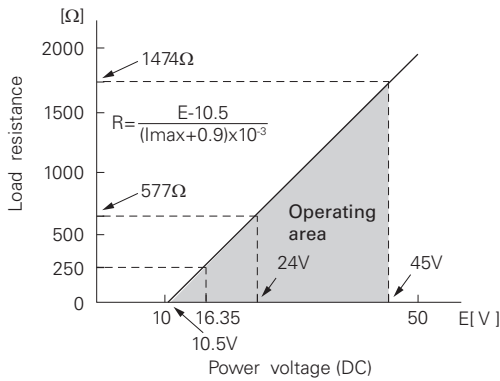

Note: For communication with HHC⁽¹⁾ (Model: FXW), min. of 250Ω is required.

Zero/span adjustment:

Zero and span are adjustable from the HHC⁽¹⁾. Zero and span are also configurator externally from the adjustment screw.

Damping:

Adjustable from HHC or local configurator unit with LCD display. The time constant is adjustable between 0.06 to 32 seconds.

Zero elevation/suppression:

Zero can be elevated or suppressed within the specified range limit of each sensor model.

Normal/reverse action:

Selectable from HHC⁽¹⁾.

Indication:

Analog indicator or 5-digit LCD meter, as specified.

Burnout direction: Selectable from HHC⁽¹⁾

If self-diagnostic detect transmitter failure, the analog signal will be driven to either "Output Hold", "Output Overscale" or "Output Underscale" modes.

"Output Hold":

Output signal is hold as the value just before failure happens.

"Output Overscale":

Adjustable within the range 20.0mA to 22.5mA from HHC⁽¹⁾

"Output Underscale":

Adjustable within the range 3.2mA to 4.0mA from HHC⁽¹⁾

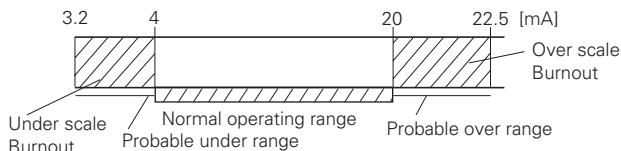

Output Limits conforming the NAMUR NE43 by order.

Loop-check output:

Transmitter can be configured to provide constant signal 3.2mA through 22.5mA by HHC⁽¹⁾.

Temperature limit:

Ambient: -40 to +85°C

(-20 to +80°C for LCD indicator)

(-40 to +60°C for arrester option)

For explosionproof units (flameproof or intrinsic safety), ambient temperature must be within the limits specified by each standard.

Process:

Fill fluid	Code in the 13th digit of "Code symbols"	Process temperature	Lower limit of static press.
Silicone oil	G	-40 to 180°C (Note)	2.7kPa abs {20mmHg abs}

Note: When capillary is PVC coated it is -40 to 120°C.

Storage: -40 to +90°C

Humidity limit: 0 to 100% RH

Communication: With HHC⁽¹⁾ (Model FXW, consult Data Sheet No. EDS8-47), following items can be remotely displayed or configured.

Note: HHC's version must be higher than 7.0 (or FXW □□□□1-□4), for FCX-AIII.

Local configurator with LCD display (option):

Local configurator with 3 push button and LCD display can support following items.

Items	By communication with FXW		By local configurator (with 3 push button)	
	Display	Set	Display	Set
Tag No.	✓	✓	✓	✓
Model No.	✓	✓	✓	✓
Serial No. & Software Version	✓	—	✓	—
Engineering unit	✓	✓	✓	✓
Range limit	✓	—	✓	—
Measuring range	✓	✓	✓	✓
Damping	✓	✓	✓	✓
Output mode	✓	—	✓	—
Burnout direction	✓	✓	✓	✓
Calibration	✓	✓	✓	✓
Output adjust	—	✓	—	✓
Data	✓	—	✓	—
Self diagnoses	✓	—	✓	—
Printer (In case of FXW with printer option)	✓	—	—	—
External switch lock	✓	✓	✓	✓
Transmitter display	✓	✓	✓	✓
Linearize	✓	✓	—	—
Rerange	✓	✓	✓	✓
Saturate current	✓	✓	✓	✓
Write protect	✓	✓	✓	✓
History				
- Calibration history	✓	✓	✓	✓
- Ambient temperature history	✓	—	✓	—

EMC Conformity: EN61326-1: 2006 CE

(Note) (1) HHC: Hand Held Communicator

Performance specifications

Reference conditions, silicone oil fill, 316SS isolating diaphragms, 4 to 20mA analog output in linear mode and capillary length of 1.5m.

Accuracy rating: (including linearity, hysteresis, and repeatability)

(Standard)

For spans greater than 1/10 of URL: $\pm 0.2\%$ of span

For spans below 1/10 of URL:

$$\pm \left(0.1 + 0.1 \frac{0.1 \times \text{URL}}{\text{Span}} \right) \% \text{ of span}$$

(Option) (Code; 21th digit H,K)

For spans greater than 1/10 of URL: $\pm 0.1\%$ of span

For spans below 1/10 of URL:

$$\pm \left(0.05 + 0.05 \frac{0.1 \times \text{URL}}{\text{Span}} \right) \% \text{ of span}$$

Stability: $\pm 0.2\%$ of upper range limit (URL) for 3 years.

Temperature effect:

Effect per 28°C change between the limits of -40°C and +85°C

(Standard) Zero shift: $\pm 0.35\%$ of URL

Total effect: $\pm 0.5\%$ of URL

(Option) (Code; 21th digit J,K)

Zero shift: $\pm 0.3\%$ of URL

Total effect: $\pm 0.4\%$ of URL

Overrange effect: Zero shift; 0.2% of URL for any overrange to maximum limit

Supply voltage effect:

Less than 0.005% of calibrated span per 1V

Update rate: 60 msec

Step response: Time constant: 0.3s (at 23°C)

Dead time: 0.12s

(without electrical damping)

Dielectric strength:

500V AC, 50/60Hz 1 min., between circuit and earth.

Insulation resistance:

More than 100M Ω /500V DC.

Turn-on time: 4 sec.

Internal resistance for external field indicator:

12 Ω or less

Physical specifications

Electrical connections:

G1/2, 1/2-14 NPT, Pg13.5, or M20 \times 1.5 conduit, as specified.

Process connections:

IDF standard 4" clamp

(In case of 6th digit code "1", "2")

IDF standard 2" clamp

(In case of 6th digit code "3")

Refer to "Code symbols."

Process-wetted parts material:

Diaphragm: 316L stainless steel

Flange face: 316 stainless steel

(Refer to "Code symbols")

Non-wetted parts material:

Electronics housing: Low copper die-cast aluminum alloy finished with polyester coating (standard) or 316 stainless steel (SCS14 per JIS G5121), as specified.

Capillary: In case of 11th code "D, E, L, F, M, N, P", PVC armored stainless steel.

In case of 11th code "Q, R, S, T, V, W, X", stainless steel armored stainless steel.

Mounting flange: 316 stainless steel

Fill fluid: Silicone oil (standard)

Mounting bracket: 304 stainless steel.

Environmental protection:

IEC IP67 and NEMA 6/6P

Mounting:

On 60.5mm (JIS 50A) pipe using mounting bracket, direct wall mounting

Mass {weight}:

Transmitter approximately 10kg without options.

Add; 0.5kg for mounting bracket

0.8kg for indicator option

4.5kg for stainless steel housing

option

Optional features

- Indicator:** A plug-in analog indicator (2.5% accuracy) can be housed in the electronics compartment or in the terminal box of the housing.
An optional 5-digit LCD meter with engineering unit is also available.
- Local configurator with LCD display:** An optional 5 digits LCD meter with 3 push buttons can support items as using communication with FXW.
- Arrester:** A built-in arrester protects the electronics from lightning surges.
Lightning surge immunity:
4kV (1.2 × 50µs)
- Degreasing:** Process-wetted parts are cleaned, but the fill fluid is standard silicone oil. Not for use on oxygen or chlorine measurement.
- Optional tag plate:** An extra stainless steel tag for customer tag data is wired to the transmitter.
- Coating of cell:** Cell's surface is finished with epoxy/polyurethane double coating. Specify if environment is extremely corrosive.

ACCESSORIES

- Hand-held communicator:**
(Model FXW, refer to Data Sheet No. EDS8-47)

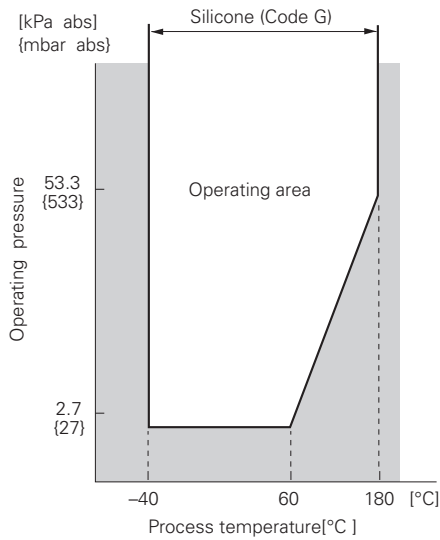

Fig. 1 Relation between process temperature and operating pressure

CODE SYMBOLS

Digit	Description	Note	1	2	3	4	5	6	7	8	9	10	11	12	13	14	15	21	← Digit No. of code
			F	K	B	0	5									Y	Y		
4	<Conduit connection>																		
	Conduit connection	Case type																	
	G1/2	T type						5											
	1/2-14NPT	T type						6											
	Pg13.5	T type						7											
	M20 x 1.5	T type						8											
	G1/2	L type						S											
	1/2-14NPT	L type						T											
	Pg13.5	L type						V											
	M20 x 1.5	L type						W											
5	<Flanges>																		
	Mounting flange	Flange size and rating	Ranges																
	316 stainless steel	IDF standard 4" clamp IDF standard 2" clamp	1 2 3 * * *						L										
								N											
6			Note 1																
	1.3.....130 {0.013...1.3}								1										
	5.....500 {0.05.....5}								2										
	30.....3000 {0.3.....30}								3										
7	<Material/diaphragm extension>																		
	Diaphragm	Flange face	Diaph. extension [mm]																
	316L stainless steel	316 stainless steel	0						V										
9	<Indicator and arrester>																		
	Indicator	Arrester																	
	None	None												A					
	Analog, 0 to 100% linear scale	None												B					
	Analog, custom scale	None												D					
	None	Yes												E					
	Analog, 0 to 100% linear scale	Yes												F					
	Analog, custom scale	Yes												H					
	Digital, 0 to 100% linear scale	None												L					
	Digital, custom scale	None												P					
	Digital, 0 to 100% linear scale	Yes												Q					
	Digital, custom scale	Yes												S					
	Digital, 0 to 100% linear scale (Local configurator unit with LCD display)	None												1					
Digital, custom scale (Local configurator unit with LCD display)	None												2						
Digital, 0 to 100% linear scale (Local configurator unit with LCD display)	Yes												4						
Digital, custom scale (Local configurator unit with LCD display)	Yes												5						
10	<Approvals for hazardous locations>																		
	None (for ordinary locations)													A					
11	<Capillary and mounting bracket>																		
	Capillary	Mounting bracket	Armor of capillary																
	1.5 m	304 Stainless steel	PVC																
	3	304 Stainless steel	PVC																
	5	304 Stainless steel	PVC																
	6	304 Stainless steel	PVC																
	7	304 Stainless steel	PVC																
	8	304 Stainless steel	PVC	Note 2															
	10	304 Stainless steel	PVC	Note 2															
	1.5	304 Stainless steel	Stainless steel																
	3	304 Stainless steel	Stainless steel																
	5	304 Stainless steel	Stainless steel																
	6	304 Stainless steel	Stainless steel																
7	304 Stainless steel	Stainless steel	Note 2																
8	304 Stainless steel	Stainless steel	Note 2																
10	304 Stainless steel	Stainless steel	Note 2																
12	<Options>																		
	Extra SS tag plate	Stainless steel elec. housing	Coating of cell																
	None	None	None																
	Yes	None	None	Note 3															
	None	None	Yes																
	Yes	None	Yes																

Note 1: (*1) 100: 1 turn down is possible, but should be used at a span greater than 1/40 of the maximum span for better performance.

Note 2: (*2) Available for 5th digit code "L".

Note 3: (*3) Customer tag number can be engraved on standard stainless steel name plate. If extra tag plate is required, select "Yes".

Digit	Description	Note	1	2	3	4	5	6	7	8	9	10	11	12	13	14	15	21	← Digit No. of code
13	<Special applications and fill fluid> Treatment Degreasing		F	K	B	0	5										Y	Y	
21	<Other options> High accuracy type Low temperature effect type H+J ----- Instruction manual unattached High accuracy type Low temperature effect type T+U	Note 4																	
																			H
																			J
																			K
																			L
																			T
																			U
																			V

Note 4: In other option is not necessary, 21st digit code is blank.

ORDERING INFORMATION

When ordering this instrument, specify.

1. CODE SYMBOLS
2. Measuring range.
3. Output orientation (burnout direction) when abnormality is occurred in the transmitter.
Hold / Overscale / Underscale
Unless otherwise specified, output hold function is supplied.
4. Indication method (indicated value and unit) in case of the actual scale (code D, H, P, S on 9th digit).
5. Tag No. (up to 14 alphanumerical characters), if required.

OUTLINE DIAGRAM (Unit:mm)

<Amp. case: L type>

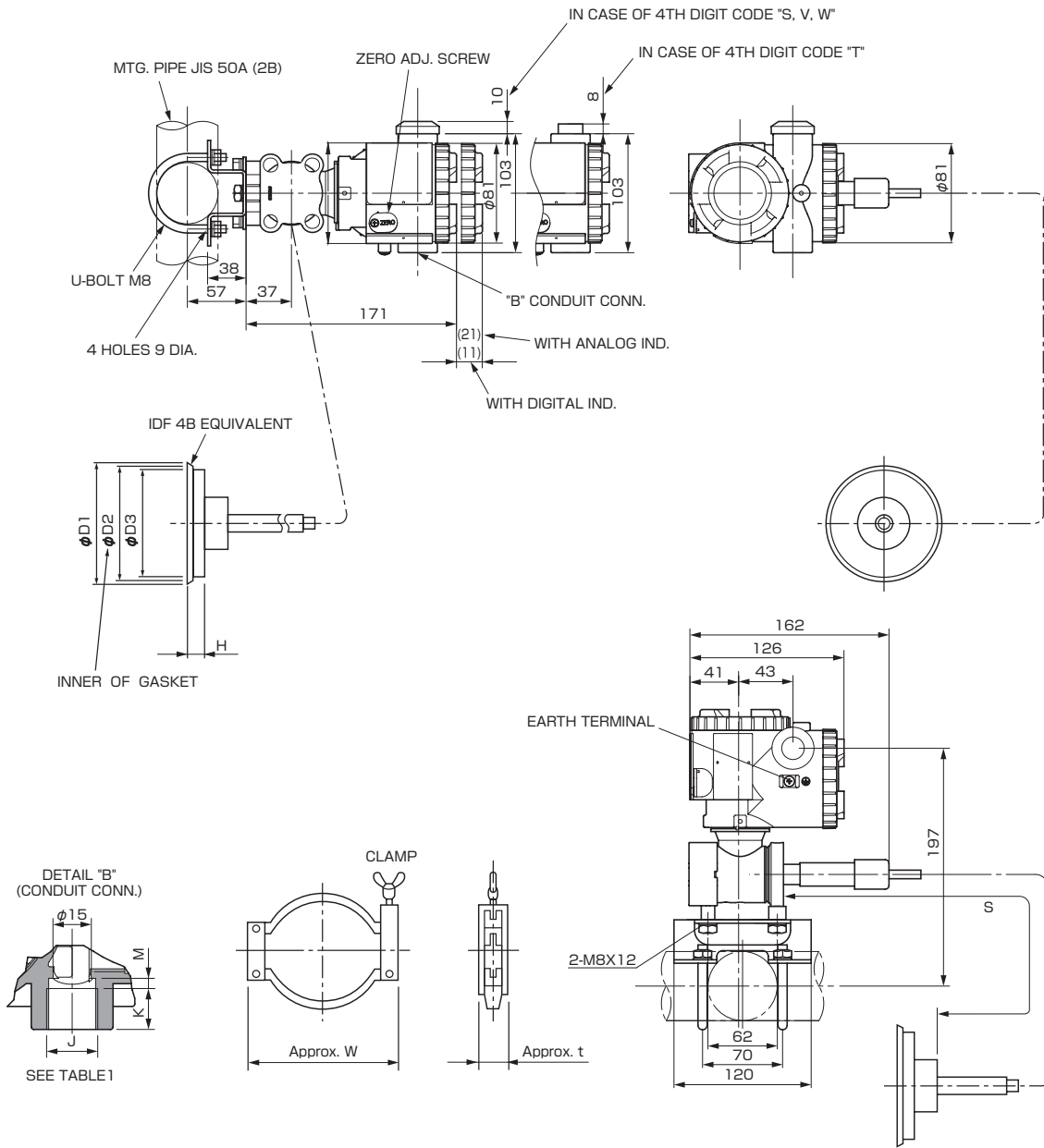

4th digit of the code symbols	Conduit conn.		
	J	K	M
S	G 1/2	18	2
T	1/2-14NPT	16	4
V	Pg13.5	10.5	4.5
W	M20x1.5	16	4

TABLE 1

5TH DIGIT CODE	φD1	φD2	φD3	H	W	t	REMARK
L	119	110	97	18	160	24	IDF 4B EQUIVALENT
N	64	56.5	49	25	100	15	IDF 2B EQUIVALENT

11th digit of the code symbols	S(m)
D, Q	1.5
E, R	3
L, S	5
F, T	6
M, V	7
N, W	8
P, X	10

CONNECTION DIAGRAM

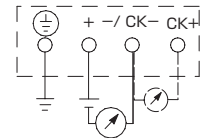

<Amp. case:T type>

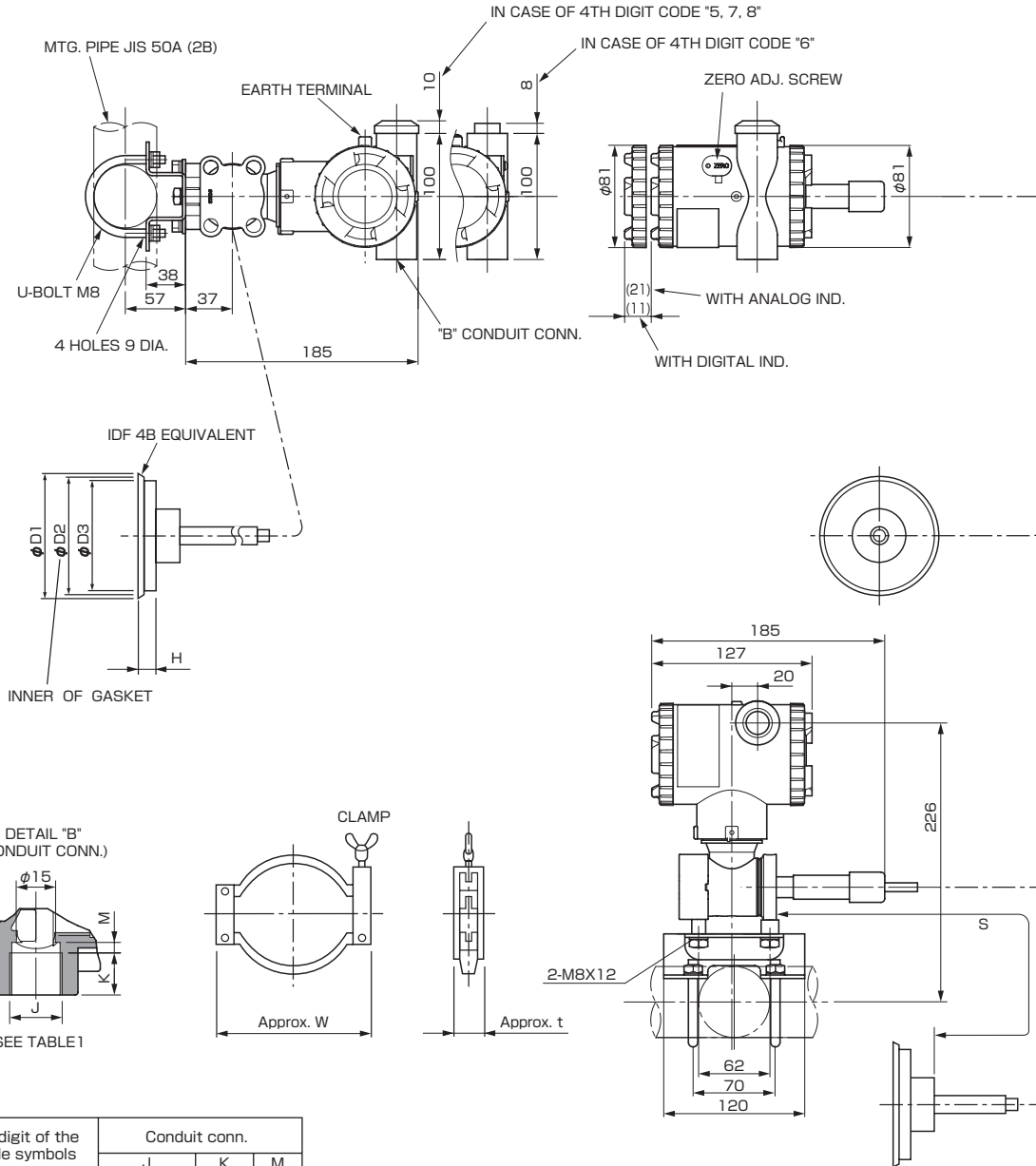

4th digit of the code symbols	Conduit conn.		
	J	K	M
5	G 1/2	18	2
6	1/2-14NPT	16	4
7	Pg13.5	10.5	4.5
8	M20x1.5	16	4

TABLE 1

11th digit of the code symbols	S(m)
D, Q	1.5
E, R	3
L, S	5
F, T	6
M, V	7
N, W	8
P, X	10

5TH DIGIT CODE	φD1	φD2	φD3	H	W	t	REMARK
L	119	110	97	18	160	24	IDF 4B EQUIVALENT
N	64	56.5	49	25	100	15	IDF 2B EQUIVALENT

CONNECTION DIAGRAM

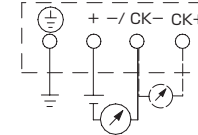

⚠ Caution on Safety

*Before using this product, be sure to read its instruction manual in advance.

Fuji Electric Systems Co., Ltd.

**International Sales Div.1
Sales Group**

Gate City Ohsaki, East Tower, 11-2, Osaki 1-chome,
Shinagawa-ku, Tokyo 141-0032, Japan

<http://www.fesys.co.jp/eng>

Phone: 81-3-5435-7280, 7281 Fax: 81-3-5435-7425

<http://www.fic-net.jp/eng>