

# SMALL FLANGE REMOTE SEAL TYPE DIFFERENTIAL PRESSURE TRANSMITTER

DATA SHEET

FKX...5

The FCX-AIII small flange remote seal type differential pressure transmitter accurately measures differential pressure, liquid level or gauge pressure and transmits a proportional 4 to 20mA signal. The transmitter utilizes a unique micromachined capacitance silicon sensor with state-of-the-art microprocessor technology to provide exceptional performance and functionality. Totally welded construction of the seals assures excellent reliability in high temperature and highly corrosive process conditions.

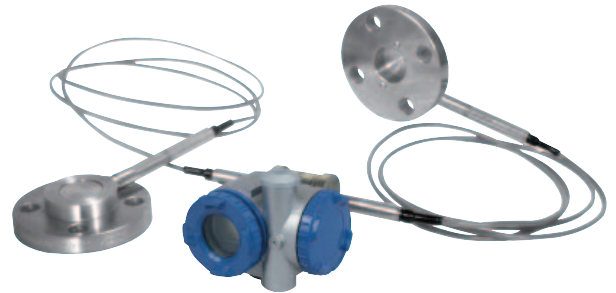

## FEATURES

- 1. Directly connectable to 1-1/2 in and 2in flanges**  
The transmitter is connectable to 1-1/2 in and 2in pipes without a reducer.
- 2. Flow measurement without impulse piping**  
1/2 in and 3/4 in flange size is also available. This differential pressure transmitter allows connection to 1/2 in and 3/4 in flanges of a general size for the orifice tap, which eliminates the need of using a impulse piping. Problems with the impulse piping, such as clogging, leaks or corrosion can be solved. In addition, the following process connection is also available.  
Screw connection 1/2-14NPT, 3/4-14NPT, Rc 1/2, Rc 3/4
- 3. Minimum environmental influence**  
The "Advanced Floating Cell" design which protects the pressure sensor against changes in temperature, static pressure, and overpressure substantially reduces total measurement error in actual field applications.
- 4. Fuji/HART® bilingual communications protocol**  
FCX-AIII series transmitter offers bilingual communications to speak both Fuji proprietary protocol and HART®. Any HART® compatible devices can communicate with FCX-AIII.
- 5. Application flexibility**  
Various options that render the FCX-AIII suitable for almost any process applications include:
  - Full range of hazardous area approvals
  - Built-in RFI filter and lightning arrester
  - 5-digit LCD meter with engineering unit
  - Stainless steel electronics housing
  - Wide selection of materials
  - High temperature, high vacuum seals
- 6. Programmable output Linearization Function**  
In addition to Linear and Square Root, output signal can be freely programmable.  
(Up to 14 compensated points at approximation.)
- 7. Burnout current flexibility (Under Scale: 3.2 to 4.0mA, Over Scale: 20.0 to 22.5mA)**  
Burnout signal level is adjustable using Model FXW Hand Held Communicator (HHC) to comply with NAMUR NE43.

- 8. Dry calibration without reference pressure**  
Thanks to the best combination of unique construction of mechanical parts (Sensor unit) and high performance electronics circuit (Electronics unit), reliability of dry calibration without reference pressure is at equal level as wet calibration.

## SPECIFICATIONS

### Functional specifications

**Service:** Liquid, gas, or vapour  
**Static pressure, span, and range limit:**

Type	Static pressure	Span limit [kPa] (m bar)		Range limit [kPa] (m bar)
		Min.	Max.	
FKX□□3	Up to flange rating	3	32	+/- 32
FKX□□5		{ 30 }	{ 320 }	{ +/- 320 }
FKX□□6		{130}	{1300}	{ +/- 1300 }
		50	500	+/- 500
		{500}	{5000}	{ +/- 5000 }

- Maximum static pressure limit for screw connection type: 4.2MPa
- Lower limit of static pressure (vacuum limit),  
Silicone fill sensor: See Fig. 1  
Fluorinated fill sensor: Atmospheric pressure
- The maximum span of each sensor can be converted to different units using factors as below.  
1MPa = 10<sup>3</sup>kPa = 10bar = 10.19716kgf/cm<sup>2</sup>  
= 145.0377psi  
1kPa = 10mbar = 101.976mmH<sub>2</sub>O = 4.01463H<sub>2</sub>O

**Overrange limit:** To maximum static pressure limit  
**Output signal:** 4 to 20mA DC (linear or square root) with digital signal superimposed on the 4 to 20mA signal.  
**Power supply:** Transmitter operates on 10.5V to 45V DC at transmitter terminals.  
 10.5V to 32V DC for the units with optional arrester.

**Load limitations:** see figure below

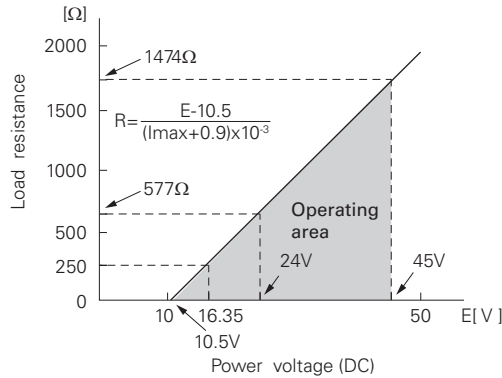

Note: For communication with HHC<sup>(1)</sup> (Model: FXW), min. of 250Ω is required.

**Hazardous locations:** SEE TABLE2

**Zero/span adjustment:**

Zero and span are adjustable from the HHC<sup>(1)</sup>. Zero and span are also adjustable externally from the adjustment screw.

**Damping:** Adjustable from HHC or local configurator unit with LCD display.  
 The time constant is adjustable between 0.06 to 32 seconds.

**Zero elevation/suppression:**  
 -100% to +100% of URL

**Normal/reverse action:**  
 Selectable from HHC<sup>(1)</sup>

**Indication:** Analog indicator or 5-digit LCD meter, as specified.

**Burnout direction:** Selectable from HHC<sup>(1)</sup>  
 If self-diagnostic detect transmitter failure, the analog signal will be driven to either "Output Hold", "Output Overscale" or "Output Underscale" modes.

**"Output Hold":**  
 Output signal is hold as the value just before failure happens.

**"Output Overscale":**  
 Adjustable within the range 20.0mA to 22.5mA from HHC<sup>(1)</sup>

**"Output Underscale":**  
 Adjustable within the range 3.2mA to 4.0mA from HHC<sup>(1)</sup>

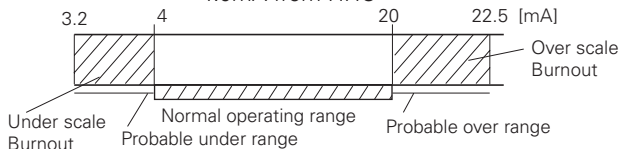

Output limits conforming to NAMUR NE43 by order.

**Loop-check output:**  
 Transmitter can be configured to provide constant signal 3.2mA through 22.5mA by HHC<sup>(1)</sup>.

**Temperature limit:**  
 Ambient: -15 to + 65°C  
 (-15 to + 60°C for arrester option)  
 (-10 to + 60°C for fluorinated oil fill transmitter)  
 (-10 to + 60°C for silicone oil "H", "S")  
 (-15 to + 45°C for capillary length more than 7m)  
 For explosionproof units (flameproof or intrinsic safety), ambient temperature must be within the limits specified in each standard.

**Process:**

Fill fluid	13th digit of "Code symbols"	Process temperature	Lower limit of static press.
Fluorinated oil	W, A and D	-20 to 120°C	Atmospheric pressure
Silicone oil	H	0 to 250°C	2.7kPa abs {20mmHg abs}
	Y and G	-40 to 180°C	
	S	0 to 250°C	

**Storage:** -40 to +70°C

**Humidity limit:** 0 to 100% RH

**Communication:** With HHC<sup>(1)</sup> (Model FXW, consult Data Sheet No. EDS8-47), following items can be remotely displayed or configured.

Note: HHC's version must be higher than 7.0 (or FXW □□□□1-□4), for FCX-AIII.

**Local configurator with LCD display (option):**

Local configurator with 3 push button and LCD display can support following items.

Items	By communication with FXW		By local configurator (with 3 push button)	
	Display	Set	Display	Set
Tag No.	✓	✓	✓	✓
Model No.	✓	✓	✓	✓
Serial No. & Software Version	✓	—	✓	—
Engineering unit	✓	✓	✓	✓
Range limit	✓	—	✓	—
Measuring range	✓	✓	✓	✓
Damping	✓	✓	✓	✓
Output mode	Linear	✓	✓	✓
	Square root	✓	✓	✓
Burnout direction	✓	✓	✓	✓
Calibration	✓	✓	✓	✓
Output adjust	—	✓	—	✓
Data	✓	—	✓	—
Self diagnoses	✓	—	✓	—
Printer (In case of FXW with printer option)	✓	—	—	—
External switch lock	✓	✓	✓	✓
Transmitter display	✓	✓	✓	✓
Linearize	✓	✓	—	—
Rerange	✓	✓	✓	✓
Saturate current	✓	✓	✓	✓
Write protect	✓	✓	✓	✓
History				
- Calibration history	✓	✓	✓	✓
- Ambient temperature history	✓	—	✓	—

**Programmable output linearization function:**

Output signal can be characterized with "14 points linear approximation function" from HHC<sup>(1)</sup>.

**EMC Conformity:** EN61326-1: 2006 CE

(Note) (1) HHC: Hand Held Communicator

## Performance specifications

Reference conditions, silicone oil fill, 316SS isolating diaphragms, 4 to 20mA analog output in linear mode and capillary length 3m.

**Accuracy rating:** (including linearity, hysteresis, and repeatability)

(Standard)

For spans greater than  $\frac{1}{10}$  of URL: 0.25% of span

For spans below  $\frac{1}{10}$  of URL:

$$\pm \left( 0.17 + 0.08 \frac{0.1 \times \text{URL}}{\text{Span}} \right) \% \text{ of span}$$

(Option) (Code; 21th digit H,K)

For spans greater than  $\frac{1}{10}$  of URL: 0.1% of span

For spans below  $\frac{1}{10}$  of URL:

$$\pm \left( 0.05 + 0.05 \frac{0.1 \times \text{URL}}{\text{Span}} \right) \% \text{ of span}$$

**Stability:**  $\pm 0.2\%$  of upper range limit (URL) for 10 years.

**Temperature effect:**

Effects per 28°C change between the limits of -15°C and +65°C

Zero shift:  $\pm 0.5\%/28^\circ\text{C}$

(x equal to  $\frac{1}{2}$  URL or more)

$$\text{Zero shift; } \pm \left( 0.5 \frac{\text{URL}}{2x} \right) \% / 28^\circ\text{C}$$

(x less than  $\frac{1}{2}$  URL)

Total shift;  $\pm 0.75\%/28^\circ\text{C}$

(x less than  $\frac{1}{2}$  URL or more)

$$\text{Total shift; } \pm \left( 0.25 + 0.5 \frac{\text{URL}}{2x} \right) \% / 28^\circ\text{C}$$

(x less than  $\frac{1}{2}$  URL)

(option) (Code; 21th digit J,K)

Zero shift:  $\pm 0.5\%/28^\circ\text{C}$

(x equal to  $\frac{1}{6.5}$  URL or more)

$$\text{Zero shift; } \pm \left( 0.5 \frac{\text{URL}}{6.5x} \right) \% / 28^\circ\text{C}$$

(x less than  $\frac{1}{6.5}$  URL)

Total shift;  $\pm 0.75\%/28^\circ\text{C}$

(x equal to  $\frac{1}{6.5}$  URL or more)

$$\text{Total shift; } \pm \left( 0.25 + 0.5 \frac{\text{URL}}{6.5x} \right) \% / 28^\circ\text{C}$$

(x less than  $\frac{1}{6.5}$  URL)

Where, x: Calibrated span

URL: Maximum span (Upper Range Limit)

Note: Above specifications are based on the conditions that flanges and sensor unit are at the same temperature and in the same level. If temperature is different at flanges, capillary or sensor unit, output variation may increase.

**Static pressure effect:**

Zero shift; 0.2% of URL/1MPa (10 bar)

Span shift: -0.2% of calibrated span /1MPa

**Overrange effect:** Zero shift; 0.1% of URL for flange rating pressure

**Supply voltage effect:**

Less than 0.005% of calibrated span per 1V

**Update rate:** 60 msec

**Step response:** (without electrical damping)

Time constant (at 23°C)	Dead time
1.7 s	0.12 s

**Dielectric strength:**

500V AC, 50/60Hz 1 min., between circuit and earth.

**Insulation resistance:**

More than 100MΩ at 500V DC.

**Internal resistance for external field indicator:**

12Ω or less

## Physical specifications

### Electrical connections:

G<sup>1</sup>/<sub>2</sub>, 1/2-14 NPT, Pg13.5, or M20 x 1.5 conduit, as specified.

### Process connections:

JIS  
10K, 20K, 30K - 40, 50A  
10K, 20K, 30K - 15, 20A (with Adapter)  
ANSI/JPI  
150LB, 300LB - 1 1/2", 2"  
150LB, 300LB - 1/2", 3/4" (with Adapter)  
Screw connection (with Adapter);  
Rc<sup>1</sup>/<sub>2</sub>, Rc<sup>3</sup>/<sub>4</sub>, 1/2 - 14NPT, 3/4 - 14NPT

### Diaphragm extension:

0, 50, 100, 150, or 200mm as specified.  
(See model code. Extended diaphragm is available only with 316L stainless steel diaphragm)

### Process-wetted parts material:

Diaphragm: 316L stainless steel, Hastelloy-C, Monel or Tantalum  
Flange face: 316 stainless steel, Hastelloy-C lining, Monel lining, or Tantalum lining  
Extension: 316 stainless steel

### Non-wetted parts material:

Electronics housing: Low copper die-cast aluminum alloy finished with polyester coating (standard), or 316 stainless steel (ASTM CF8M), as specified.  
Capillary: In case of 11th code "D. E. L.", PVC armored stainless steel.  
In case of 11th code "Q. R. S", stainless steel armored stainless steel.  
Mounting flange: 304 stainless steel or carbon steel.  
Fill fluid: Silicone oil (standard) or fluorinated oil  
Mounting bracket: 304 stainless steel

### Environmental protection:

IEC IP67 and NEMA 6/6P

### Mounting:

On 60.5mm (JIS 50A) pipe using mounting bracket, direct wall mounting

### Mass {weight}:

Transmitter approximately 12.7 to 30.7kg without options.  
Add; 0.5kg for mounting bracket  
4.5kg for stainless steel housing option  
1.5kg per 50mm extension of diaphragm

## Optional features

### Indicator:

A plug-in analog indicator (2.5% accuracy) can be housed in the electronics compartment or in the terminal box of the housing.

An optional 5-digit LCD meter with engineering unit is also available.

### Local configurator with LCD display:

An optional 5 digits LCD meter with 3 push buttons can support items as using communication with FXW.

### Arrester:

A built-in arrester protects the electronics from lightning surges.

Lightning surge immunity: 4kV (1.2 × 50μs).

### Oxygen service:

Special cleaning procedures are followed throughout the process to maintain all process wetted parts oil-free.

The fill fluid is fluorinated oil.

### Chlorine service:

Oil-free procedures as above. Includes fluorinated oil for fill.

### Degreasing:

Process-wetted parts are cleaned, but the fill fluid is standard silicone oil. Not for use on oxygen or chlorine measurement.

### Vacuum service:

Special silicone oil and filling procedure are applied.

See Fig. 1.

### Optional tag plate:

An extra stainless steel tag for customer tag data is wired to the transmitter.

### Coating of cell:

Cell's surface is finished with epoxy/polyurethane double coating. Specify if environment is extremely corrosive.

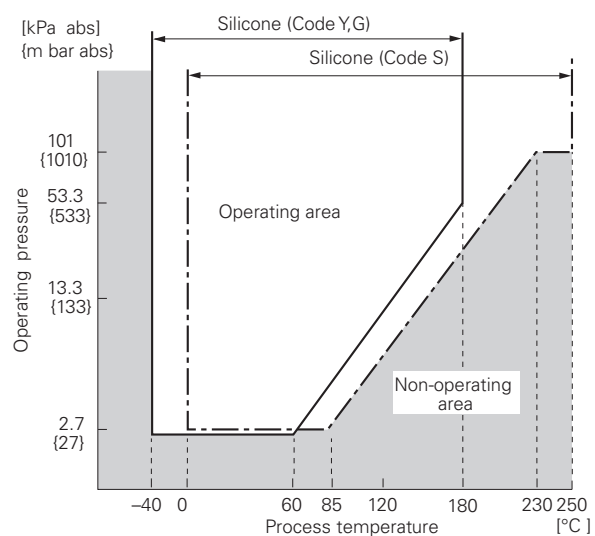

Fig. 1 Relation between process temperature and operating pressure

## ACCESSORIES

### Hand-held communicator:

(Model FXW, refer to Data Sheet No. EDS 8-47)

# CODE SYMBOLS

Digit	Description	Note	1	2	3	4	5	6	7	8	9	10	11	12	13	14	15	16	17	18	19	20	21 ← Digit No. of code	
4	<Connections> <Conduit connection>      <Case type> G1/2                                    T type 1/2-14NPT                            T type Pg 13.5                                T type M20 x 1.5                            T type ----- G1/2                                    L type 1/2-14NPT                            L type Pg 13.5                                L type M20 x 1.5                            L type		F	K	X					5														
5	<Flange> Material                                Size and rating 304 stainless steel                    JIS 10K 40A JIS 10K 50A JIS 20K 40A JIS 20K 50A JIS 30K 40A JIS 30K 50A JIS 63K 40A JIS 63K 50A ----- ANSI/JPI 150LB 1 1/2" ANSI/JPI 150LB 2" ANSI/JPI 300LB 1 1/2" ANSI/JPI 300LB 2" ANSI/JPI 600LB 1 1/2B ANSI/JPI 600LB 2B ----- Carbon steel                            JIS 10K 40A JIS 10K 50A JIS 20K 40A JIS 20K 50A JIS 30K 40A JIS 30K 50A JIS 63K 40A JIS 63K 50A ----- ANSI/JPI 150LB 1 1/2" ANSI/JPI 150LB 2" ANSI/JPI 300LB 1 1/2" ANSI/JPI 300LB 2" ANSI/JPI 600LB 1 1/2B ANSI/JPI 600LB 2B ----- None                                        40A, 1 1/2B (Wafer type)                            50A, 2B ----- Direct mounting adapter connection (* 1)																							
6	<Span limit [kPa] {m bar}> 3.....32(30...320) 13.....130(130...1300) 50.....500(500...5000)																							
7	<Material/diaphragm extension> Diaphragm                                Flange face                                Diaphragm extension(mm) 316L stainless steel                    316 stainless steel                        0 316L stainless steel                    316 stainless steel                        50 316L stainless steel                    316 stainless steel                        100 316L stainless steel                    316 stainless steel                        150 316L stainless steel                    316 stainless steel                        200 316L stainless steel                    316 stainless steel                        0 +Au coating Hastelloy-C                                316 stainless steel                        0 ----- Hastelloy-C                                Hastelloy-C                                 0 Monel                                        Monel                                         0 Tantalum                                    Tantalum	Note 2																						

Note 1: (\*1) Direct mounting adapter type is specified at 16th to 20th digit.  
Direct mounting adapter is available only for 7th digit code "V".  
Note 2: (\*2) Diaphragm extension is available only for 2" (50A) flanges.



## Specifications of Connecting pipe less adapter {for 15, 20A (1/2, 3/4") connection} and others

- Note 1. When ordering the instrument with connecting pipe less adapter, specify "Y" in the 5th digit of Code Symbol, and specify 16th digit to 20th digit.  
 When ordering the instrument without connecting pipe less adapter, nothing should be filled in the 16th to 20th digit.
2. Unless otherwise described in the specifications, leave the 21st digit blank.

Digit	Description	Note	1	2	3	4	5	6	7	8	9	10	11	12	13	14	15	16	17	18	19	20	21
16, 17	<Process connection (connecting pipe less adapter)> JIS 10K 15A JIS 10K 20A JIS 20K 15A JIS 20K 20A JIS 30K 15A JIS 30K 20A ----- ANSI/JPI 150LB 1/2" ANSI/JPI 150LB 3/4" ANSI/JPI 300LB 1/2" ANSI/JPI 300LB 3/4" ----- Screw connection Rc1/2 Screw connection Rc3/4 Screw connection Rc1/2 - 14NPT Screw connection Rc3/4 - 14NPT		F	K	X					5							0						
18	<Material (connecting pipe less adapter)> (*5) Adapter Bolts/nuts (* 5) 316 Stainless Steel Cr-Mo steel/carbon steel	Note 5																					
19	<Vent/drain (for connecting pipe less adapter)> Standard Long type																						
20	<Gasket (for connecting pipe less adapter)> Standard (Teflon) (Only Y, W, G, A and D can be specified on 13th digit). For high temperature (spiral gasket) (Only H and S can be specified on 13th digit).																						
21	<Other options> (*6) High accuracy type Instruction manual attached Low temperature effect type Instruction manual attached H+J Instruction manual attached ----- Instruction manual unattached High accuracy type Instruction manual unattached Low temperature effect type Instruction manual unattached T+U Instruction manual unattached	Note 6																					

Note 5: (\*5) For connection of transmitter receiving pressure unit and connecting pipe less adapter  
 Note 6: (\*6) If other option is not necessary, 21st digit code is blank.  
 In case of 21st digit code is blank, instruction manual attached.

## ORDERING INFORMATION

When ordering this instrument, specify:

1. CODE SYMBOLS
2. Measuring range
3. Output orientation (burnout direction) when abnormality is occurred in the transmitter.  
Hold / Overscale / Underscale  
Unless otherwise specified, output hold function is supplied.
4. Output mode (linear or square root output)  
Unless otherwise specified, output mode is linear.
5. Indication method (indicated value and unit) in case of the actual scale (code D, H, P, S on 9th digit).
6. Tag No. (up to 14 alphanumeric characters), if required.

# OUTLINE DIAGRAM (Unit:mm)

< CODE SYMBOLS : FKX 

S	V	0~7
T	W	A~X

			5
--	--	--	---

 >

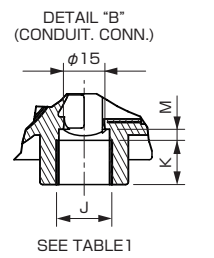
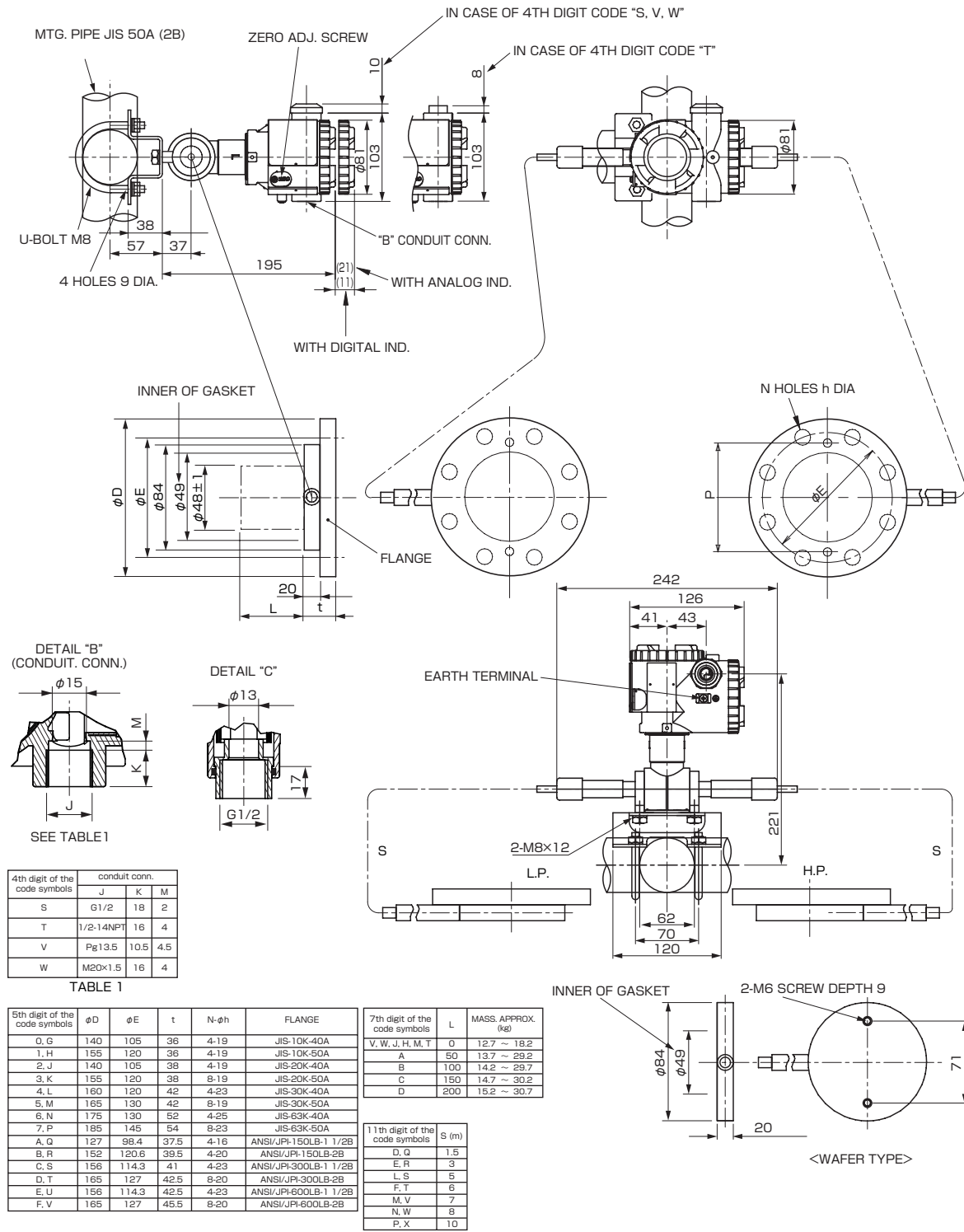

4th digit of the code symbols	conduit conn.		
	J	K	M
S	G1/2	18	2
T	1/2-14NPT	16	4
V	PG13.5	10.5	4.5
W	M20x1.5	16	4

TABLE 1

5th digit of the code symbols	phi D	phi E	t	N-phi h	FLANGE
0, G	140	105	36	4-19	JIS-10K-40A
1, H	155	120	36	4-19	JIS-10K-50A
2, J	140	105	38	4-19	JIS-20K-40A
3, K	155	120	38	8-19	JIS-20K-50A
4, L	160	120	42	4-23	JIS-30K-40A
5, M	165	130	42	8-19	JIS-30K-50A
6, N	175	130	52	4-25	JIS-63K-40A
7, P	185	145	54	8-23	JIS-63K-50A
A, Q	127	98.4	37.5	4-16	ANSI/JPI-150LB-1 1/2B
B, R	152	120.6	39.5	4-20	ANSI/JPI-150LB-2B
C, S	156	114.3	41	4-23	ANSI/JPI-300LB-1 1/2B
D, T	165	127	42.5	8-20	ANSI/JPI-300LB-2B
E, U	156	114.3	42.5	4-23	ANSI/JPI-600LB-1 1/2B
F, V	165	127	45.5	8-20	ANSI/JPI-600LB-2B

7th digit of the code symbols	L	MASS. APPROX. (kg)
V, W, J, H, M, T	0	12.7 ~ 18.2
A	50	13.7 ~ 29.2
B	100	14.2 ~ 29.7
C	150	14.7 ~ 30.2
D	200	15.2 ~ 30.7

11th digit of the code symbols	S (m)
D, Q	1.5
E, R	3
L, S	5
F, T	6
M, V	7
N, W	8
P, X	10

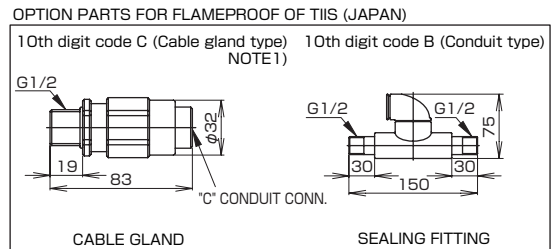

NOTE1) IN CASE OF 10TH CODE "C", phi 11 CABLE IS SUITABLE.

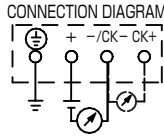

< CODE SYMBOLS : FKX 

5	7	0~7
6	8	A~X

□	□	5
---	---	---

 >

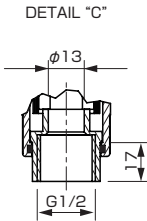
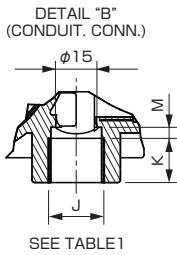
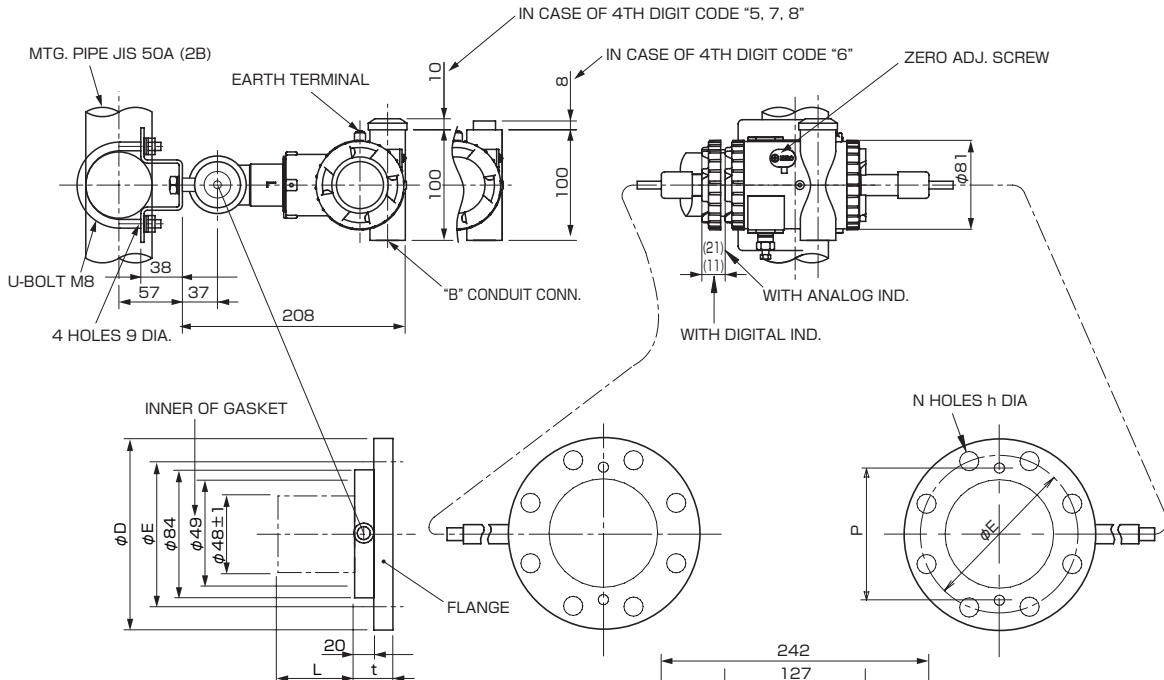

4th digit of the code symbols	conduit conn.		
	J	K	M
5	G1/2	18	2
6	1/2-14NPT	16	4
7	Ph13x5	10.5	4.5
8	M20x1.5	16	4

TABLE 1

5th digit of the code symbols	phi D	phi E	t	N-phi n	FLANGE	7th digit of the code symbols	L	MASS. APPROX. (kg)
0, G	140	105	36	4-19	JIS-10K-40A	V, W, J, H, M, T	0	12.7 ~ 18.2
1, H	155	120	36	4-19	JIS-10K-50A	A	50	13.7 ~ 29.2
2, J	140	105	38	4-19	JIS-20K-40A	B	100	14.2 ~ 29.7
3, K	155	120	38	8-19	JIS-20K-50A	C	150	14.7 ~ 30.2
4, L	160	120	42	4-23	JIS-30K-40A	D	200	15.2 ~ 30.7
5, M	165	130	42	8-19	JIS-30K-50A	11th digit of the code symbols S (m)		
6, N	175	130	52	4-25	JIS-33K-40A	D, Q	1.5	
7, P	185	145	54	8-23	JIS-33K-50A	E, R	3	
A, Q	127	98.4	37.5	4-16	ANSI/JPI-150LB-1 1/2B	L, S	5	
B, R	152	120.6	39.5	4-20	ANSI/JPI-150LB-2B	F, T	6	
C, S	156	114.3	41	4-23	ANSI/JPI-300LB-1 1/2B	M, V	7	
D, T	165	127	42.5	8-20	ANSI/JPI-300LB-2B	N, W	8	
E, U	156	114.3	42.5	4-23	ANSI/JPI-600LB-1 1/2B	P, X	10	
F, V	165	127	45.5	8-20	ANSI/JPI-600LB-2B			

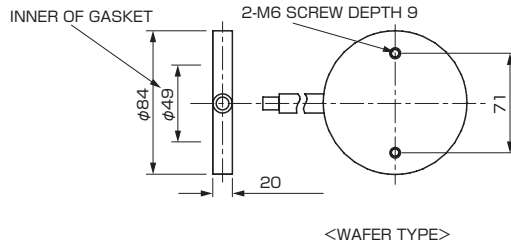

OPTION PARTS FOR FLAMEPROOF OF THIS (JAPAN)

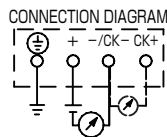
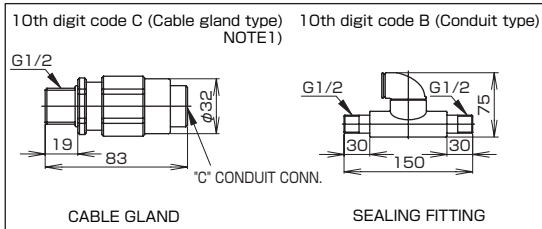

NOTE 1) IN CASE OF 10TH CODE "C", phi 11 CABLE IS SUITBLE.

< CODE SYMBOLS : FKX  $\begin{matrix} S \\ T \\ W \end{matrix}$  Y  $\square\square$  5- $\square\square\square\square$ - $\square\square$ S >

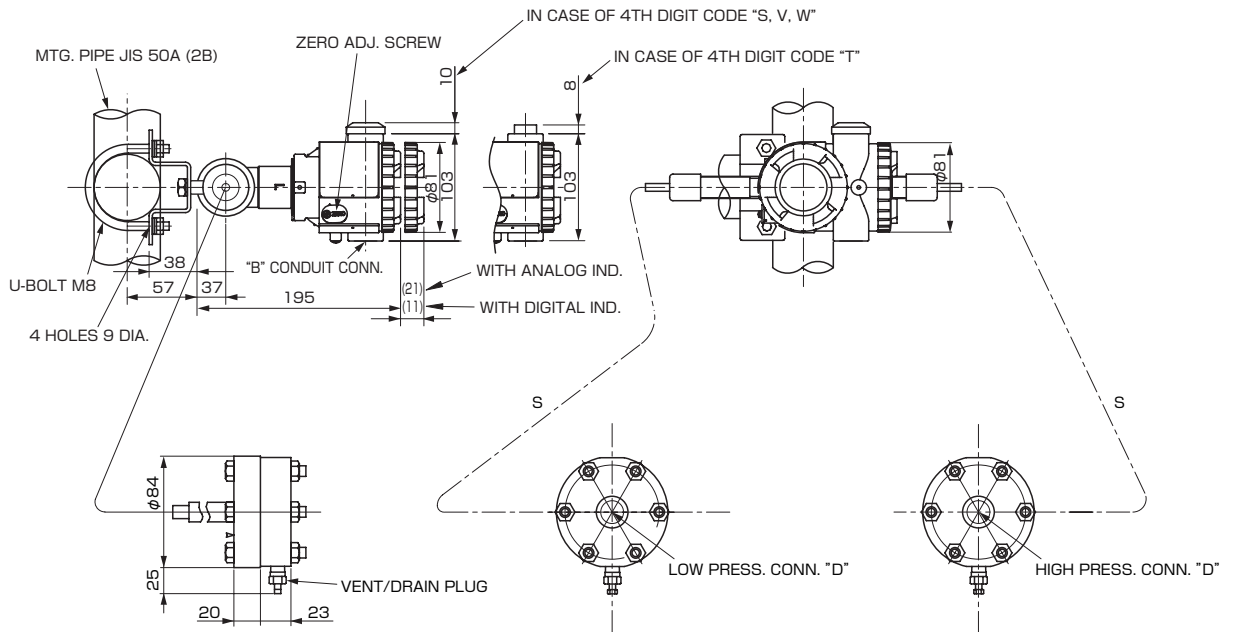

DETAIL "B"  
(CONDUIT. CONN.)

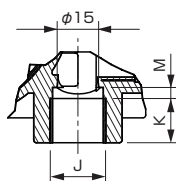

SEE TABLE 1

DETAIL "C"

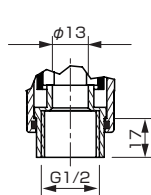

4th digit of the code symbols	conduit conn.		
	J	K	M
S	G1/2	18	2
T	1/2-14NPT	16	4
V	Pg13.5	10.5	4.5
W	M20x1.5	16	4

TABLE 1

16th digit of the code symbols	17th digit of the code symbols	Press. conn. "D"
S	R	Rc 1/2
S	N	1/2-14NPT
S	2	Rc 3/4
S	T	3/4-14NPT

11th digit of the code symbols	S (m)
D, Q	1.5
E, R	3
L, S	5
F, T	6
M, V	7
N, W	8
P, X	10

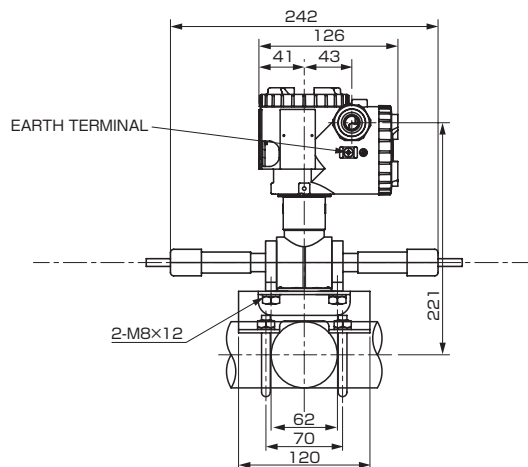

CONNECTION DIAGRAM

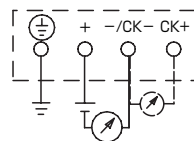

OPTION PARTS FOR FLAMEPROOF OF TIIS (JAPAN)

10th digit code C (Cable gland type) 10th digit code B (Conduit type)  
NOTE1)

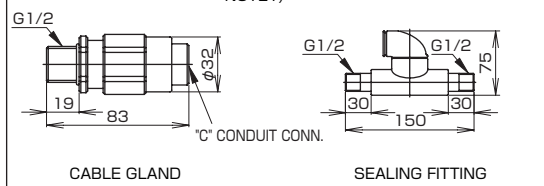

NOTE1) IN CASE OF 10TH CODE "C",  $\phi 11$  CABLE IS SUITBLE.

< CODE SYMBOLS : FKX  $\begin{matrix} 5 & 7 \\ 6 & 8 \end{matrix}$  Y  $\square\square\square$ 5- $\square\square\square\square$ - $\square\square$ S >

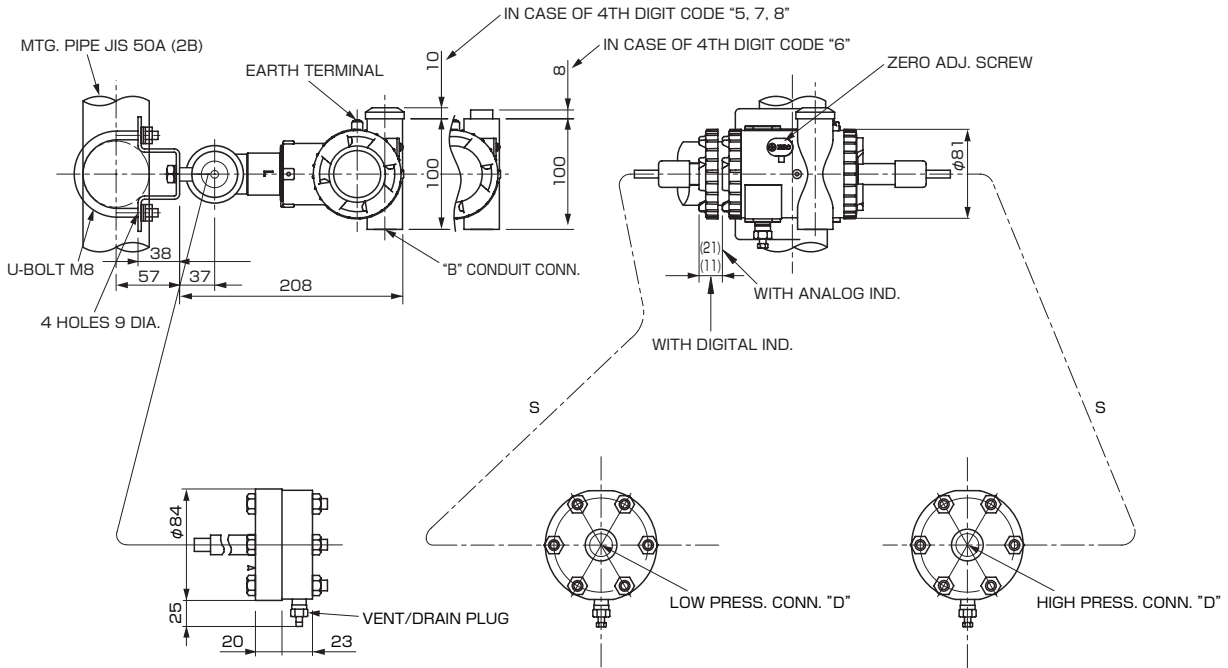

DETAIL "B"  
(CONDUIT. CONN.)

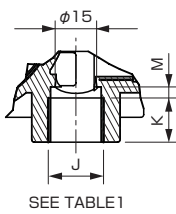

DETAIL "C"

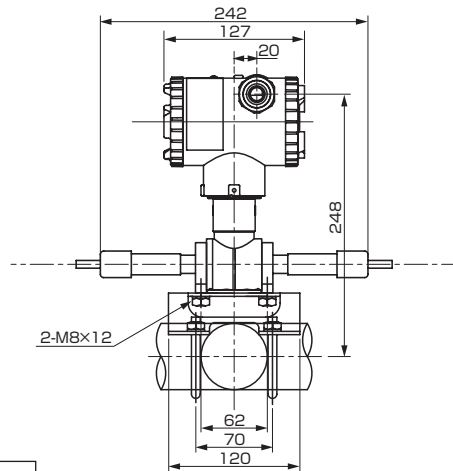
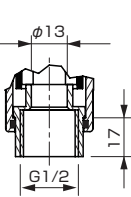

4th digit of the code symbols	conduit conn.		
	J	K	M
5	G1/2	18	2
6	1/2-14NPT	16	4
7	Pg13.5	10.5	4.5
8	M20x1.5	16	4

TABLE 1

16th digit of the code symbols	17th digit of the code symbols	Press. conn. "D"
S	R	Rc 1/2
S	N	1/2-14NPT
S	2	Rc 3/4
S	T	3/4-14NPT

11th digit of the code symbols	S (m)
D, Q	1.5
E, R	3
L, S	5
F, T	6
M, V	7
N, W	8
P, X	10

CONNECTION DIAGRAM

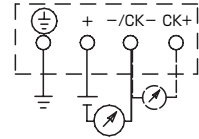

OPTION PARTS FOR FLAMEPROOF OF TIIS (JAPAN)

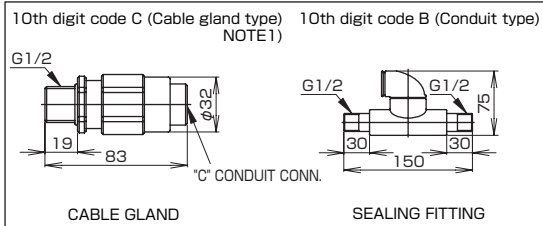

NOTE 1) IN CASE OF 10TH CODE "C",  $\phi 11$  CABLE IS SUITABLE.





TABLE 2

Authorities	Intrinsic safety	Authorities	Flameproof																					
ATEX	Ex II 1 G Ex ia IIC T5 Tamb = -40°C to +50°C Ex ia IIC T4 Tamb = -40°C to +70°C  Entity Parameters: Ui=28V, li=94.3mA, Pi=0.66W, Ci=26nF (Without Arrester), Li=0.6mH (Without analog indicator), Ci=36nF (With Arrester), Li=0.7mH (With analog indicator)	ATEX	Ex II 2 GD Ex d IIC T6 IP66/67 T85°C Tamb = -40°C to +65°C Ex d IIC T5 IP66/67 T100°C Tamb = -40°C to +85°C																					
Factory Mutual	Class I II III Div.1 Groups A, B, C, D, E, F, G T4 Entity Type 4X <table border="1"> <thead> <tr> <th colspan="2">Model code</th> <th>Tamb</th> </tr> <tr> <th>9th digit</th> <th>13th digit</th> <th></th> </tr> </thead> <tbody> <tr> <td>A,B,C,D,J</td> <td>Y,G,H,S</td> <td>-40°C to +85°C</td> </tr> <tr> <td>L,P,M,1,2,3</td> <td>Y,G,H,S</td> <td>-20°C to +80°C</td> </tr> <tr> <td>Q,S,N,4,5,6</td> <td>Y,G,H,S</td> <td>-20°C to +60°C</td> </tr> <tr> <td>E,F,G,H,K</td> <td>Y,G,H,S</td> <td>-40°C to +60°C</td> </tr> <tr> <td>-</td> <td>W,A,D</td> <td>-10°C to +60°C</td> </tr> </tbody> </table> Entity Parameters: Vmax=28V, Imax=94.3mA, Pi=0.66W, Ci=35.98nF, Li=0.694mH	Model code		Tamb	9th digit	13th digit		A,B,C,D,J	Y,G,H,S	-40°C to +85°C	L,P,M,1,2,3	Y,G,H,S	-20°C to +80°C	Q,S,N,4,5,6	Y,G,H,S	-20°C to +60°C	E,F,G,H,K	Y,G,H,S	-40°C to +60°C	-	W,A,D	-10°C to +60°C	Factory Mutual	Class I Div.1 Groups B, C, D T6 Type 4X Class II III Div.1 Groups E, F, G T6 Type 4X Tamb max = +60°C
Model code		Tamb																						
9th digit	13th digit																							
A,B,C,D,J	Y,G,H,S	-40°C to +85°C																						
L,P,M,1,2,3	Y,G,H,S	-20°C to +80°C																						
Q,S,N,4,5,6	Y,G,H,S	-20°C to +60°C																						
E,F,G,H,K	Y,G,H,S	-40°C to +60°C																						
-	W,A,D	-10°C to +60°C																						
CSA	Class I Div.1 Groups A, B, C, D Class II Div.1 Groups E, F, G Class III Div.1 Temp Code T5 Tamb max = +50°C Temp Code T4 Tamb max = +70°C Entity Parameters: Vmax=28V, Imax=94.3mA, Ci=25nF (Without Arrester), Ci=36nF (With Arrester), Li=0.6mH (Without analog meter), Li=0.7mH (With analog meter)	CSA	Class I Div.1 Groups C, D Class II Div.1 Groups E, F, G Class III Div.1  Note) "Seal Not Required" enclosure is allowed.																					
TIIS	Ex ia IIC T4 Tamb max = +60°C Entity Parameter: Ui=28V, li=94.3mA, Pi=0.66W, Ci=38.4nF, Li=0.694mH	TIIS	Ex do IIB+H2 T4 Tamb max = +60°C Maximum process temp.=+120°C																					
IECEx Scheme	Ex ia IIC T4 Tamb = -40°C to +70°C Ex ia IIC T5 Tamb = -40°C to +50°C Entity Parameters: Ui=28V, li=94.3mA, Pi=0.66W, Ci=26nF (Without Arrester), Li=0.6mH (Without analog indicator), Ci=36nF (With Arrester), Li=0.7mH (With analog indicator)	IECEx Scheme	Ex d IIC T5 IP66/67 Tamb = -40°C to +85°C Ex d IIC T6 IP66/67 Tamb = -40°C to +65°C																					
NEPSI	Ex ia IIC T4 Ex d IIB+H2 T6 / Ex ia IIC T4 <table border="1"> <thead> <tr> <th colspan="2">Model code</th> <th>Tamb</th> </tr> <tr> <th>9th digit</th> <th>13th digit</th> <th></th> </tr> </thead> <tbody> <tr> <td>A,B,C,D,J</td> <td>Y,G,H,S</td> <td>-40°C to +85°C</td> </tr> <tr> <td>L,P,M,1,2,3</td> <td>Y,G,H,S</td> <td>-20°C to +80°C</td> </tr> <tr> <td>Q,S,N,4,5,6</td> <td>Y,G,H,S</td> <td>-20°C to +60°C</td> </tr> <tr> <td>E,F,G,H,K</td> <td>Y,G,H,S</td> <td>-40°C to +60°C</td> </tr> <tr> <td>-</td> <td>W,A,D</td> <td>-10°C to +60°C</td> </tr> </tbody> </table> Entity Parameters: Ui=42.4V, li=113mA, Pi=1W, Ci=35.98nF, Li=0.694mH	Model code		Tamb	9th digit	13th digit		A,B,C,D,J	Y,G,H,S	-40°C to +85°C	L,P,M,1,2,3	Y,G,H,S	-20°C to +80°C	Q,S,N,4,5,6	Y,G,H,S	-20°C to +60°C	E,F,G,H,K	Y,G,H,S	-40°C to +60°C	-	W,A,D	-10°C to +60°C	NEPSI	Ex d IIB+H2 T6 Tamb = -40°C to +60°C
Model code		Tamb																						
9th digit	13th digit																							
A,B,C,D,J	Y,G,H,S	-40°C to +85°C																						
L,P,M,1,2,3	Y,G,H,S	-20°C to +80°C																						
Q,S,N,4,5,6	Y,G,H,S	-20°C to +60°C																						
E,F,G,H,K	Y,G,H,S	-40°C to +60°C																						
-	W,A,D	-10°C to +60°C																						
		Authorities	Type n Nonincendive																					
		ATEX	Ex II 3 GD EEx nL IIC T5 Tamb = -40°C to +50°C EEx nL IIC T4 Tamb = -40°C to +70°C Specific Parameters: Model without arrester: Ui=42.4V, li=113mA, Pi=1W, Ci=25.18nF, Li=0.694mH Model with arrester: Ui=32V, li=113mA, Pi=1W, Ci=35.98nF, Li=0.694mH  EEx nAL IIC T5 Tamb = -40°C to +50°C EEx nAL IIC T4 Tamb = -40°C to +70°C Specific Parameters: Model without arrester: Umax=42.4V, Imax=113mA, Pmax=1W, Model with arrester: Umax=32V, Imax=113mA, Pmax=1W																					
		Factory Mutual (pending)	Class I II III Div.2 Groups A, B, C, D, F, G T4 Entity Type 4X <table border="1"> <thead> <tr> <th colspan="2">Model code</th> <th>Tamb</th> </tr> <tr> <th>9th digit</th> <th>13th digit</th> <th></th> </tr> </thead> <tbody> <tr> <td>A,B,C,D,J</td> <td>Y,G,H,S</td> <td>-40°C to +85°C</td> </tr> <tr> <td>L,P,M,1,2,3</td> <td>Y,G,H,S</td> <td>-20°C to +80°C</td> </tr> <tr> <td>Q,S,N,4,5,6</td> <td>Y,G,H,S</td> <td>-20°C to +60°C</td> </tr> <tr> <td>E,F,G,H,K</td> <td>Y,G,H,S</td> <td>-40°C to +60°C</td> </tr> <tr> <td>-</td> <td>W,A,D</td> <td>-10°C to +60°C</td> </tr> </tbody> </table>	Model code		Tamb	9th digit	13th digit		A,B,C,D,J	Y,G,H,S	-40°C to +85°C	L,P,M,1,2,3	Y,G,H,S	-20°C to +80°C	Q,S,N,4,5,6	Y,G,H,S	-20°C to +60°C	E,F,G,H,K	Y,G,H,S	-40°C to +60°C	-	W,A,D	-10°C to +60°C
Model code		Tamb																						
9th digit	13th digit																							
A,B,C,D,J	Y,G,H,S	-40°C to +85°C																						
L,P,M,1,2,3	Y,G,H,S	-20°C to +80°C																						
Q,S,N,4,5,6	Y,G,H,S	-20°C to +60°C																						
E,F,G,H,K	Y,G,H,S	-40°C to +60°C																						
-	W,A,D	-10°C to +60°C																						
		CSA	Class I Div.2 Groups A, B, C, D Class II Div.2 Groups E, F, G Class III Div.2 Temp Code T5 Tamb max = +50°C Temp Code T4 Tamb max = +70°C Entity Parameters: Vmax=28V, Ci=25.18nF (Without Arrester), Ci=35.98nF (With Arrester), Li=0.694mH																					

⚠ Caution on Safety

\*Before using this product, be sure to read its instruction manual in advance.

---

## **Fuji Electric Systems Co., Ltd.**

**International Sales Div.1**

**Sales Group**

Gate City Ohsaki, East Tower, 11-2, Osaki 1-chome,  
Shinagawa-ku, Tokyo 141-0032, Japan

<http://www.fesys.co.jp/eng>

Phone: 81-3-5435-7280, 7281 Fax: 81-3-5435-7425

<http://www.fic-net.jp/eng>