

REMOTE SEAL TYPE DIFFERENTIAL PRESSURE TRANSMITTER <SANITARY TYPE>

DATA SHEET

FKD...5

The FCX-AIII differential pressure transmitter accurately measures differential pressure, liquid level or gauge pressure and transmits a proportional 4 to 20mA signal. The transmitter utilizes a unique micromachined capacitance silicon sensor with state-of-the-art microprocessor technology to provide exceptional performance and functionality. Totally welded construction of the seals assures excellent reliability in high temperature and highly corrosive process conditions.



FEATURES

- High accuracy**
0.2% accuracy for all calibrated spans is a standard feature for all DP models covering 0.32kPa {3.2mbar} range to 500kPa {5bar} high differential pressure range. 0.1% accuracy is available as option. Fuji's micro-capacitance silicon sensor assures this accuracy for all elevated or suppressed calibration ranges without additional adjustment.
- Minimum environmental influence**
The "Advanced Floating Cell" design which protects the pressure sensor against changes in temperature, static pressure, and overpressure substantially reduces total measurement error in actual field applications.
- Fuji/HART® bilingual communications protocol**
FCX-AIII series transmitter offers bilingual communications to speak both Fuji proprietary protocol and HART®. Any HART® compatible devices can communicate with FCX-AIII.
- Application flexibility**
Various options that render the FCX-AIII suitable for almost any process applications include:
 - Built-in RFI filter and lightning arrester
 - 5-digit LCD meter with engineering unit
 - Stainless steel electronics housing
 - Wide selection of materials
 - High temperature, high vacuum seals
- Programmable output Linearization Function**
In addition to Linear and Square Root, output signal can be freely programmable.
(Up to 14 compensated points at approximation.)
- Burnout current flexibility (Under Scale: 3.2 to 4.0mA, Over Scale: 20.0 to 22.5mA)**
Burnout signal level is adjustable using Model FXW Hand Held Communicator (HHC) to comply with NAMUR NE43.
- Dry calibration without reference pressure**
Thanks to the best combination of unique construction of mechanical parts (Sensor unit) and high performance electronics circuit (Electronics unit), reliability of dry calibration without reference pressure is at equal level as wet calibration.

SPECIFICATIONS

Functional specifications

Service: Liquid, gas, or vapour
Static pressure, span, and range limit:

Type	Static pressure	Span limit [kPa] (m bar)		Range limit [kPa] (m bar)
		Min.	Max.	
FKD□□3	Up to flange rating	0.32 { 3.2 }	32 { 320 }	+/- 32 { +/- 320 }
FKD□□5		1.3 { 13 }	130 { 1300 }	+/- 130 { +/- 1300 }
FKD□□6		5 { 50 }	500 { 5000 }	+/- 500 { +/- 5000 }

Remark : To minimize environmental influence, span should be greater than ¹/₄₀ of the max. span in most applications.

- Lower limit of static pressure (vacuum limit),
Silicone fill sensor: See Fig. 1

- The maximum span of each sensor can be converted to different units using factors as below.

$$1\text{MPa} = 10^3\text{kPa} = 10\text{bar} = 10.19716\text{kgf/cm}^2 = 145.0377\text{psi}$$

$$1\text{kPa} = 10\text{mbar} = 101.976\text{mmH}_2\text{O} = 4.01463\text{H}_2\text{O}$$

Overrange limit: To maximum static pressure limit

Output signal: 4 to 20mA DC (linear or square root) with digital signal superimposed on the 4 to 20mA signal.

Power supply: Transmitter operates on 10.5V to 45V DC at transmitter terminals.
10.5V to 32V DC for the units with optional arrester.

Load limitations: see figure below

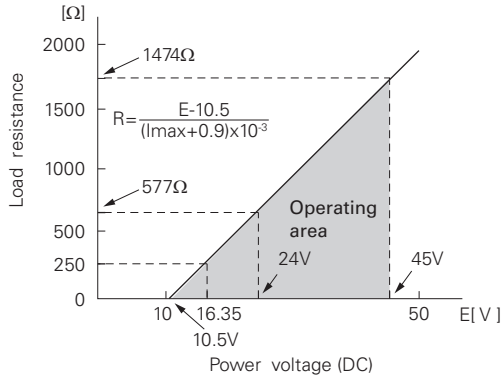

Note: For communication with HHC⁽¹⁾ (Model: FXW), min. of 250Ω is required.

Zero/span adjustment:

Zero and span are adjustable from the HHC⁽¹⁾. Zero and span are also adjustable externally from the adjustment screw.

Damping:

Adjustable from HHC or local configurator unit with LCD display. The time constant is adjustable between 0.06 to 32 seconds.

Zero elevation/suppression:

-100% to +100% of URL

Normal/reverse action:

Selectable from HHC⁽¹⁾

Indication:

Analog indicator or 5-digit LCD meter, as specified.

Burnout direction: Selectable from HHC⁽¹⁾

If self-diagnostic detect transmitter failure, the analog signal will be driven to either "Output Hold", "Output Overscale" or "Output Underscale" modes.

"Output Hold":

Output signal is hold as the value just before failure happens.

"Output Overscale":

Adjustable within the range 20.0mA to 22.5mA from HHC⁽¹⁾

"Output Underscale":

Adjustable within the range 3.2mA to 4.0mA from HHC⁽¹⁾

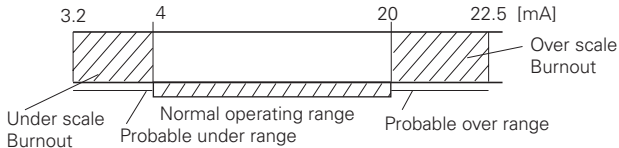

Output limits conforming to NAMUR NE43 by order.

Loop-check output:

Transmitter can be configured to provide constant signal 3.2mA through 22.5mA by HHC⁽¹⁾.

Temperature limit:

- Ambient: -40 to + 85°C
- (-20 to + 80°C for LCD indicator)
- (-40 to + 60°C for arrester option)

Process:

Fill fluid	Code in the 13th digit of "Code symbols"	Process temperature	Lower limit of static press
Silicone oil	G	-40 to 180°C (Note)	2.7kPa abs (20mmHg abs)

Note: When capillary is PVC coated it is -40 to 120°C. Storage: -40 to + 90°C

Humidity limit: 0 to 100% RH

Communication: With HHC⁽¹⁾ (Model FXW, consult Data Sheet No. EDS8-47), following items can be remotely displayed or configured.

Note: HHC's version must be higher than 7.0 (or FXW □□□□1-□4), for FCX-AIII.

Local configurator with LCD display (option):

Local configurator with 3 push button and LCD display can support following items.

Items	By communication with FXW		By local configurator (with 3 push button)	
	Display	Set	Display	Set
Tag No.	✓	✓	✓	✓
Model No.	✓	✓	✓	✓
Serial No. & Software Version	✓	—	✓	—
Engineering unit	✓	✓	✓	✓
Range limit	✓	—	✓	—
Measuring range	✓	✓	✓	✓
Damping	✓	✓	✓	✓
Output mode	Linear	✓	✓	✓
	Square root	✓	✓	✓
Burnout direction	✓	✓	✓	✓
Calibration	✓	✓	✓	✓
Output adjust	—	✓	—	✓
Data	✓	—	✓	—
Self diagnoses	✓	—	✓	—
Printer (In case of FXW with printer option)	✓	—	—	—
External switch lock	✓	✓	✓	✓
Transmitter display	✓	✓	✓	✓
Linearize	✓	✓	—	—
Rerange	✓	✓	✓	✓
Saturate current	✓	✓	✓	✓
Write protect	✓	✓	✓	✓
History				
- Calibration history	✓	✓	✓	✓
- Ambient temperature history	✓	—	✓	—

Programmable output linearization function:

Output signal can be characterized with "14 points linear approximation function" from HHC⁽¹⁾.

EMC Conformity: EN61326-1: 2006

(Note) (1) HHC: Hand Held Communicator

Performance specifications

Reference conditions, silicone oil fill, 316SS isolating diaphragms, 4 to 20mA analog output in linear mode and capillary length of 1.5m.

Accuracy rating: (including linearity, hysteresis, and repeatability)

(Standard)

For spans greater than 1/10 of URL: $\pm 0.2\%$ of span

For spans below 1/10 of URL:

$$\pm \left(0.1 + 0.1 \frac{0.1 \times \text{URL}}{\text{Span}} \right) \% \text{ of span}$$

(Option) (Code; 21th digit H,K)

For span greater than 1/10 of URL: 0.1% of span

For span below 1/10 of URL:

$$\pm \left(0.05 + 0.05 \frac{0.1 \times \text{URL}}{\text{Span}} \right) \% \text{ of span}$$

Stability: $\pm 0.2\%$ of upper range limit (URL) for 3 years.

Temperature effect (*):

Effects per 28°C change between the limits of -40°C and + 85°C

(Standard) Zero shift: $\pm 0.35\%$ of URL

Total effect: $\pm 0.5\%$ of URL

(Option) (Code; 21th digit J,K)

Zero shift: $\pm 0.3\%$ of URL

Total effect: $\pm 0.4\%$ of URL

Note: *Excluding effects by temperature difference between the seals.

Static pressure effect:

Zero shift: $\pm 0.2\%$ of URL / 1MPa

Span shift: -0.2% of calibrated span / 1MPa

Overrange effect: Zero shift; $\pm 0.1\%$ of URL for flange rating pressure

Supply voltage effect:

Less than 0.005% of calibrated span per 1V

Update rate: 60 msec

Step response: (without electrical damping)

Dielectric strength:

Range code	Time constant (at 23°C)	Dead time
"3"	2 s	0.12 s
"5"	1.7 s	
"6"	1.7 s	

500V AC, 50/60Hz 1 min., between circuit and earth.

Insulation resistance:

More than $100M\Omega$ at 500V DC.

Internal resistance for external field indicator:

12Ω or less

Physical specifications

Electrical connections:

G1/2, 1/2-14 NPT, Pg13.5, or M20 \times 1.5 conduit, as specified.

Process connections:

IDF standard 4" clamp.

See OUTLINE DIAGRAM for detailed dimensions.

Process-wetted parts material:

Diaphragm: 316L stainless steel

Flange face: 316 stainless steel

Extension: 316 stainless steel

Non-wetted parts material:

Electronics housing: Low copper die-cast aluminum alloy finished with polyester coating (standard), or 316 stainless steel (SCS14 per JIS G5121), as specified.

Capillary: In case of 11th code "D, E, F, L, M, N, P", PVC armored stainless steel.

In case of 13th code "Q, R, S, T, V, W, X", stainless steel armored stainless steel.

Mounting flange: 316 stainless steel

Fill fluid: Silicone oil (standard)

Mounting bracket: 304 stainless steel

Environmental protection:

IEC IP67 and NEMA 6/6P

Mounting:

On 60.5mm (JIS 50A) pipe using mounting bracket, direct wall mounting

Mass(weight):

Transmitter approximately 15kg without options.

Add; 0.5kg for mounting bracket

0.8kg for indicator option

4.5kg for stainless steel housing option

Optional features

- Indicator:** A plug-in analog indicator (2.5% accuracy) can be housed in the electronics compartment or in the terminal box of the housing.
An optional 5-digit LCD meter with engineering unit is also available.
- Local configurator with LCD display:** An optional 5 digits LCD meter with 3 push buttons can support items as using communication with FXW.
- Arrester:** A built-in arrester protects the electronics from lightning surges.
Lightning surge immunity:
4kV ($1.2 \times 50\mu\text{s}$)
- Degreasing:** Process-wetted parts are cleaned, but the fill fluid is standard silicone oil. Not for use on oxygen or chlorine measurement.
- Optional tag plate:** An extra stainless steel tag for customer tag data is wired to the transmitter.
- Coating of cell:** Cell's surface is finished with epoxy/polyurethane double coating. Specify if environment is extremely corrosive.

ACCESSORIES

Hand held communicator:

(Model FXW, refer to Data Sheet No. EDS 8-47)

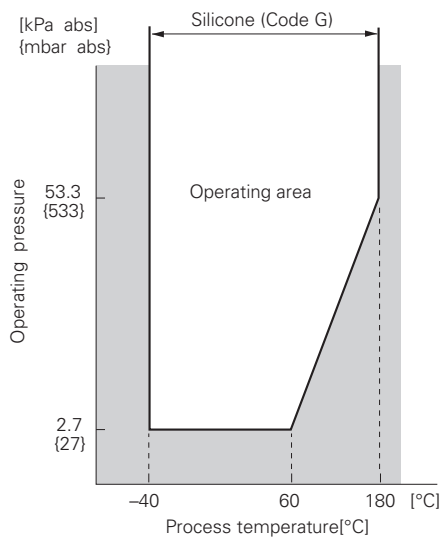
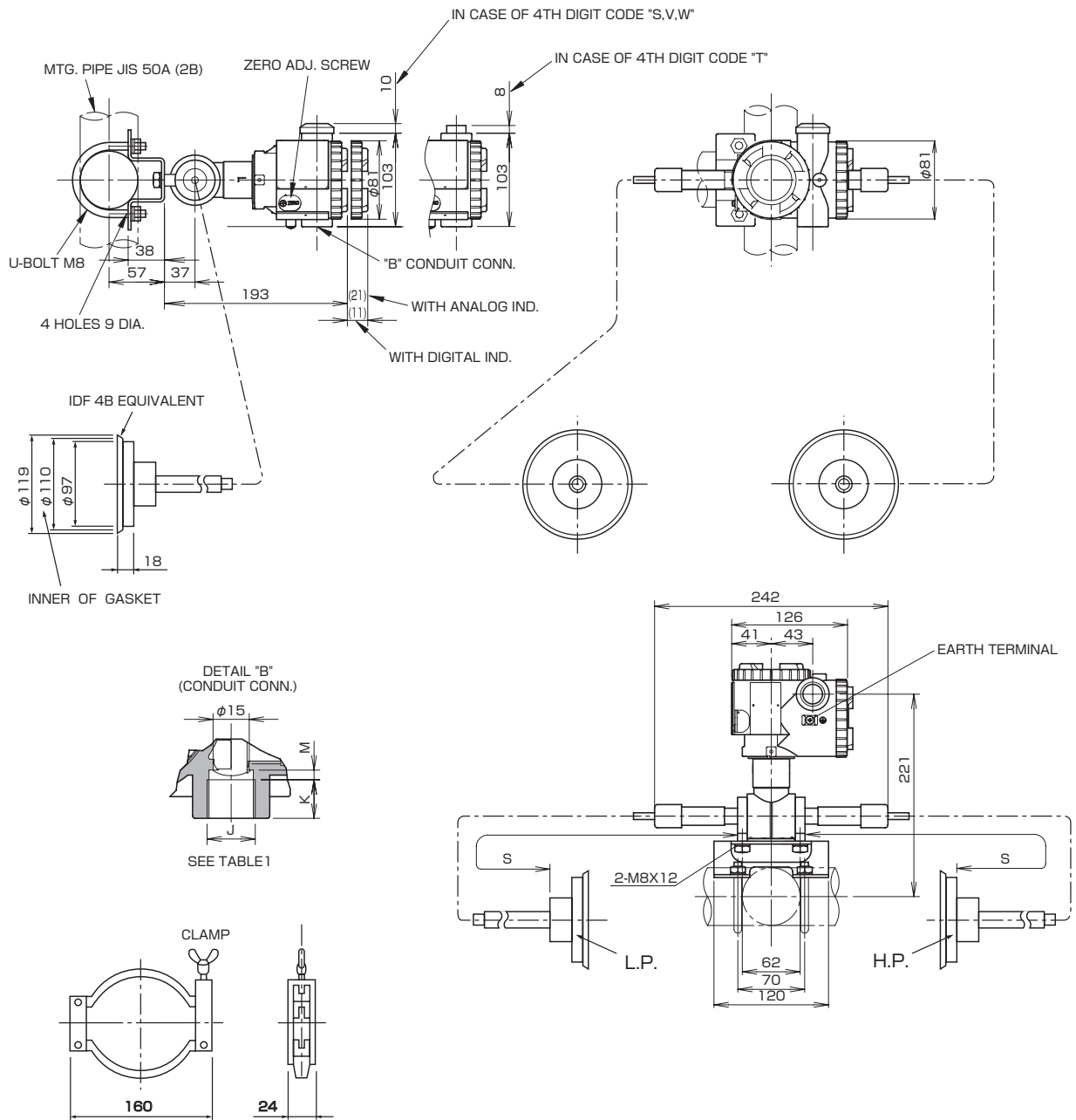

Fig. 1 Relation between process temperature and operating pressure

OUTLINE DIAGRAM (Unit:mm)

<Amp. case: L type>



4th digit of the code symbols	Conduit conn.		
	J	K	M
S	G 1/2	18	2
T	1/2-14NPT	16	4
V	Pg13.5	10.5	4.5
W	M20x1.5	16	4

TABLE 1

11th digit of the code symbols	S(m)
D, Q	1.5
E, R	3
L, S	5
F, T	6
M, V	7
N, W	8
P, X	10

CONNECTION DIAGRAM

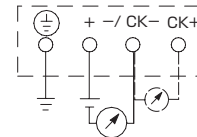

<Amp. case: T type>

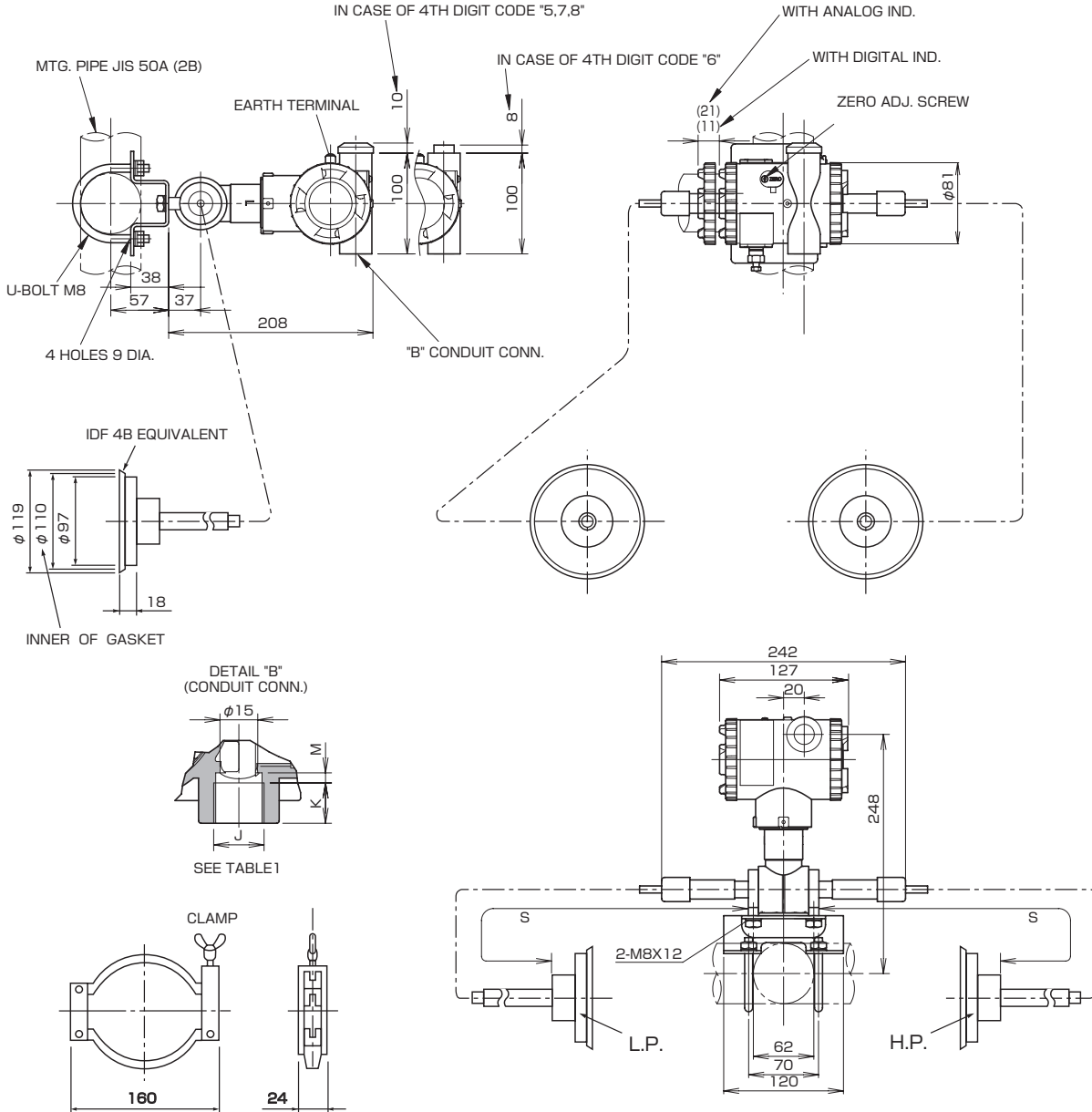

4th digit of the code symbols	Conduit conn.		
	J	K	M
5	G 1/2	18	2
6	1/2-14NPT	16	4
7	Pg13.5	10.5	4.5
8	M20x1.5	16	4

TABLE 1

11th digit of the code symbols	S(m)
D, Q	1.5
E, R	3
L, S	5
F, T	6
M, V	7
N, W	8
P, X	10

CONNECTION DIAGRAM

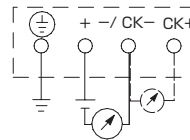

⚠ Caution on Safety

*Before using this product, be sure to read its instruction manual in advance.

Fuji Electric Systems Co., Ltd.

**International Sales Div.1
Sales Group**

Gate City Ohsaki, East Tower, 11-2, Osaki 1-chome,
Shinagawa-ku, Tokyo 141-0032, Japan

<http://www.fesys.co.jp/eng>

Phone: 81-3-5435-7280, 7281 Fax: 81-3-5435-7425

<http://www.fic-net.jp/eng>