

# LEVEL TRANSMITTER <SANITARY TYPE>

DATA SHEET

FKE...5

The FCX -AIII level transmitter accurately measures liquid level and transmits a proportional 4 to 20mA signal. The transmitter utilizes a unique micromachined capacitance silicon sensor with state-of-the-art microprocessor technology to provide exceptional performance and functionality.

## FEATURES

- High accuracy**  
0.2% accuracy for all calibrated spans is a standard feature for all models covering 0.32kPa {3.2mbar} range to 500kPa {5bar} high differential pressure range. 0.1% accuracy is available as option. Fuji's micro-capacitance silicon sensor assures this accuracy for all elevated or suppressed calibration ranges without additional adjustment.
- Minimum environmental influence**  
The "Advanced Floating Cell" design which protects the pressure sensor against changes in temperature, static pressure, and overpressure substantially reduces total measurement error in actual field applications.
- Fuji/HART® bilingual communications protocol**  
FCX-AIII series transmitter offers bilingual communications to speak both Fuji proprietary protocol and HART®. Any HART® compatible devices can communicate with FCX-AIII.
- Application flexibility**  
Various options that render the FCX -AIII suitable for almost any process applications include:
  - Built-in RFI filter and lightning arrester
  - 5-digit LCD meter with engineering unit
  - Stainless steel electronics housing
  - Wide selection of materials
  - High temperature, high vacuum service.
- Programmable output Linearization Function**  
Output signal can be freely programmable. (Up to 14 compensated points at approximation.)
- Burnout current flexibility (Under Scale: 3.2 to 4.0mA, Over Scale: 20.0 to 22.5mA)**  
Burnout signal level is adjustable using Model FXW Hand Held Communicator (HHC) to comply with NAMUR NE43.
- Dry calibration without reference pressure**  
Thanks to the best combination of unique construction of mechanical parts (Sensor unit) and high performance electronics circuit (Electronics unit), reliability of dry calibration without reference pressure is at equal level as wet calibration.



## SPECIFICATIONS

- Accuracy:  $\pm 1/40$  of the max. span in most applications.
- Lower limit of static pressure (vacuum limit) ;  
Silicone fill sensor: See Fig.1
- The maximum span of each sensor can be converted

Type	Static pressure	Span limit [kPa] {m bar}		Range limit [kPa] {m bar}
		Min.	Max.	
FKE□□3	Up to flange rating	0.32	32	+/- 32
FKE□□5		{3.2}	{320}	{ +/- 320}
FKE□□6		{13}	{1300}	{ +/- 1300}
		5	500	+/- 500
		{50}	{5000}	{ +/- 5000}

to  
different units using factors as below.  
 $1\text{MPa}=10^3\text{kPa}=10\text{bar}=10.19716\text{kgf/cm}^2=145.0377\text{psi}$   
 $1\text{kPa}=10\text{mbar}=101.9716\text{mmH}_2\text{O}=4.01463\text{inH}_2\text{O}$

- Overrange limit:** To maximum static pressure limit
- Output signal:** 4 to 20mA DC with digital signal superimposed on the 4 to 20mA signal
- Power supply:** Transmitter operates on 10.5V to 45V DC at transmitter terminals.  
10.5V to 32V DC for the units with optional arrester.

### Functional specifications

**Service:** Liquid, gas, or vapour  
**Static pressure, span, and range limit:**  
 Remark: To minimize environmental influence, span should be greater

Load limitations: see figure below

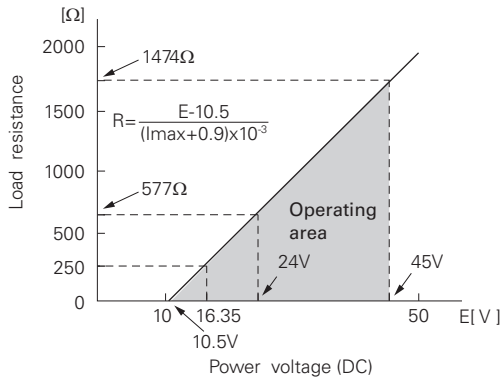

Note: For communication with HHC<sup>(1)</sup> (Model: FXW), min. of 250Ω required.

**Zero/span adjustment:**

Zero and span are adjustable from the HHC<sup>(1)</sup>. Zero and span are also adjustable externally from the adjustment screw.

**Damping:**

Adjustable from HHC or local configurator unit with LCD display. The time constant is adjustable between 0.06 to 32 seconds.

**Zero elevation/suppression:**

-100% to + 100% of URL

**Normal/reverse action:**

Selectable from HHC<sup>(1)</sup>

**Indication:**

Analog indicator or 5-digit LCD meter, as specified.

**Burnout direction:** Selectable from HHC<sup>(1)</sup>

If self-diagnostic detect transmitter failure, the analog signal will be driven to either "Output Hold", "Output Overscale" or "Output Underscale" modes.

**"Output Hold":**

Output signal is hold as the value just before failure happens.

**"Output Overscale":**

Adjustable within the range 20.0mA to 22.5mA from HHC<sup>(1)</sup>

**"Output Underscale":**

Adjustable within the range 3.2mA to 4.0mA from HHC<sup>(1)</sup>

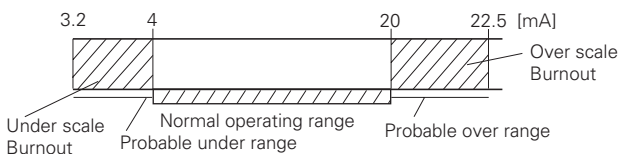

**Loop-check output:**

Transmitter can be configured to provide constant signal 3.2mA through 22.5mA by HHC<sup>(1)</sup>.

**Temperature limit:**

Ambient: -40 to + 85°C

(-20 to + 80°C for LCD indicator)

(-40 to + 60°C for arrester option)

**Process:**

Fill fluid	Code in the 13th digit of "Code symbols"	Process temperature	Lower limit of static press
Silicone oil	G	-40 to 120°C	2.7kPa abs (20.3mmHg abs)

Storage: -40 to + 90°C

**Humidity limit:** 0 to 100% RH

**Communication:** With HHC<sup>(1)</sup> (Model FXW, consult Data Sheet No. EDS8-47), following items can be remotely displayed or configured.

Note: HHC's version must be higher than 7.0 (or FXW □□□□1-□4), for FCX-AIII.

**Local configurator with LCD display (option):**

Local configurator with 3 push button and LCD display can support following items.

Items	By communication with FXW		By local configurator (with 3 push button)	
	Display	Set	Display	Set
Tag No.	✓	✓	✓	✓
Model No.	✓	✓	✓	✓
Serial No. & Software Version	✓	—	✓	—
Engineering unit	✓	✓	✓	✓
Range limit	✓	—	✓	—
Measuring range	✓	✓	✓	✓
Damping	✓	✓	✓	✓
Output mode	✓	—	✓	—
Burnout direction	✓	✓	✓	✓
Calibration	✓	✓	✓	✓
Output adjust	—	✓	—	✓
Data	✓	—	✓	—
Self diagnoses	✓	—	✓	—
Printer (In case of FXW with printer option)	✓	—	—	—
External switch lock	✓	✓	✓	✓
Transmitter display	✓	✓	✓	✓
Linearize	✓	✓	—	—
Rerange	✓	✓	✓	✓
Saturate current	✓	✓	✓	✓
Write protect	✓	✓	✓	✓
History				
- Calibration history	✓	✓	✓	✓
- Ambient temperature history	✓	—	✓	—

**Programmable output linearization function:**

Output signal can be characterized with "14 points linear approximation function" from HHC<sup>(1)</sup>.

**EMC Conformity:** EN61326-1: 2006 CE

(Note) (1) HHC: Hand Held Communicator

## Performance specifications

Reference conditions, silicone oil fill, 316SS isolating diaphragms, 4-20 mA analog output in linear mode.

**Accuracy rating:** (including linearity, hysteresis, and repeatability)

(Standard)

For spans greater than 1/10 of URL: ±0.2% of span

For spans below 1/10 of URL:

$$\pm \left( 0.1 + 0.1 \frac{0.1 \times \text{URL}}{\text{Span}} \right) \% \text{ of span}$$

(Option) (Code: 21th digit H, K)

For span greater than 1/10 of URL: 0.1% of span

For span below 1/10 of URL:

$$\pm \left( 0.05 + 0.05 \frac{0.1 \times \text{URL}}{\text{Span}} \right) \% \text{ of span}$$

**Stability:** ±0.2% of upper range limit (URL) for 3 years.

**Temperature effect:**

Effects per 28°C change between the limits of -40°C and + 85°C

(Standard) Zero shift: ±0.35% of URL

Total effect: ±0.5% of URL

(Option) (Code: 21th digit J, K)

Zero shift: ±0.3% of URL

Total effect: ±0.4% of URL

**Static pressure effect:**

Zero shift: ±0.2% of URL 1MPa

Span shift: -0.2% of calibrated span / 1MPa

**Overrange effect:** Zero shift; ±0.1% of URL for flange rating pressure

**Supply voltage effect:**

Less than 0.005% of calibrated span per 1V

**Update rate:** 60 msec

**Step response:** (without electrical damping)

Range code	Time constant (at 23°C)	Dead time
"3"	0.55 s	0.12 s
"5" and "6"	0.3 s	

**Mounting position effect:**

Zero shift, less than 0.3kPa {3m bar} for a 10° tilt in any plane. (No extension)

No effect on span.

This error can be corrected by adjusting zero.

**Dielectric strength:**

500V AC, 50/60Hz 1 min., between circuit and earth.

**Insulation resistance:**

More than 100MΩ at 500V DC.

**Turn-on time:** 4 sec

**Internal resistance for external field indicator:**

12Ω or less

## Physical specifications

**Electrical connections:**

G1/2, 1/2-14 NPT, Pg13.5, or M20 x 1.5 conduit, as specified.

**Process connections:**

LP side: 1/4-18 NPT or Rc1/4.

HP side: IDF standard 4" clamp. See OUTLINE DIAGRAM for detailed dimensions.

Refer to "Code symbols"

**Process-wetted parts material:**

Material code (7th figure in "Code symbols")	LP side			HP side
	Process cover	Diaphragm	Wetted sensor body	Diaphragm & flange face
V	316 stainless steel (*)	316L stainless steel	316 stainless steel	316L stainless steel

Note: (\*) SCS14A per JIS G 5121 (equivalent CF8M per ASTM A351/A351M)

Remark: Sensor O-rings: Viton O-ring and teflon gasket selectable.

**Non-wetted parts material:**

Electronics housing: Low copper die-cast aluminum alloy finished with polyester coating (standard), or 316 stainless steel (SCS14A per JIS G5121), as specified.

Bolts and nuts: Cr-Mo alloy (standard) or 304 stainless steel

Fill fluid: Silicone oil (standard)

Mounting flange: 316 stainless steel

**Environmental protection:**

IEC IP67 and NEMA 6 / 6P

**Flange mounting:** See drawings

**Mass{weight}:** Transmitter approximately 13kg without options.

Add; 0.5kg for mounting bracket

0.8kg for indicator option

4.5kg for stainless steel housing option

**Optional features**

- Indicator:** A plug-in analog indicator (2.5% accuracy) can be housed in the electronics compartment or in the terminal box of the housing.  
An optional 5-digit LCD meter with engineering unit is also available.
- Local configurator with LCD display:** An optional 5 digits LCD meter with 3 push buttons can support items as using communication with FXW.
- Arrester:** A built-in arrester protects the electronics from lightning surges.  
Lightning surge immunity:  
4kV (1.2 × 50µs)
- Degreasing:** Process-wetted parts are cleaned, but the fill fluid is standard silicone oil. Not for use on oxygen or chlorine measurement.
- Optional tag plate:** An extra stainless steel tag with customer tag data is wired to the transmitter.
- Coating of cell:** Cell's surface is finished with epoxy/polyurethane double coating.  
Specify if environment is extremely corrosive.

**ACCESSORIES**

- Oval flanges:** (Model FFP, refer to Data Sheet No. EDS6-128)  
Converts process connection to 1/2-14 NPT or to Rc1/2; in carbon steel or in 316 stainless steel.
- Hand held communicator:** (Model FXW, refer to Data Sheet No. EDS 8-47)

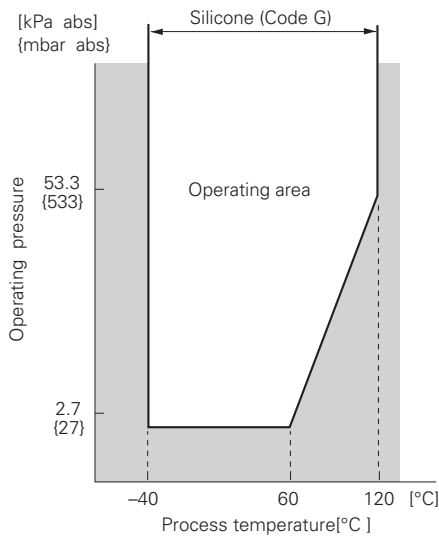

Fig. 1 Relation between process temperature and operating pressure

# CODE SYMBOLS

Digit	Description	Note	1	2	3	4	5	6	7	8	9	10	11	12	13	14	15	21	← Digit No. of code																																												
			F	K	E					5																																																					
4	<p>&lt;Connections&gt;</p> <table border="0"> <tr> <td>&lt;Process connection&gt;</td> <td>&lt;Oval flange screw&gt;</td> <td>&lt;Conduit connection&gt;</td> <td>&lt;Case type&gt;</td> </tr> <tr> <td>Rc<sup>1</sup>/<sub>4</sub></td> <td>7/16-20UNF</td> <td>G 1/2</td> <td>T type</td> </tr> <tr> <td>1/4-18NPT</td> <td>7/16-20UNF</td> <td>1/2-14NPT</td> <td>T type</td> </tr> <tr> <td>1/4-18NPT</td> <td>M10</td> <td>Pg13.5</td> <td>T type</td> </tr> <tr> <td>1/4-18NPT</td> <td>M10</td> <td>M20x1.5</td> <td>T type</td> </tr> <tr> <td>1/4-18NPT</td> <td>7/16-20UNF</td> <td>Pg13.5</td> <td>T type</td> </tr> <tr> <td>Rc<sup>1</sup>/<sub>4</sub></td> <td>7/16-20UNF</td> <td>G 1/2</td> <td>L type</td> </tr> <tr> <td>1/4-18NPT</td> <td>7/16-20UNF</td> <td>1/2-14NPT</td> <td>L type</td> </tr> <tr> <td>1/4-18NPT</td> <td>M10</td> <td>Pg13.5</td> <td>L type</td> </tr> <tr> <td>1/4-18NPT</td> <td>M10</td> <td>M20x1.5</td> <td>L type</td> </tr> <tr> <td>1/4-18NPT</td> <td>7/16-20UNF</td> <td>Pg13.5</td> <td>L type</td> </tr> </table>	<Process connection>	<Oval flange screw>	<Conduit connection>	<Case type>	Rc <sup>1</sup> / <sub>4</sub>	7/16-20UNF	G 1/2	T type	1/4-18NPT	7/16-20UNF	1/2-14NPT	T type	1/4-18NPT	M10	Pg13.5	T type	1/4-18NPT	M10	M20x1.5	T type	1/4-18NPT	7/16-20UNF	Pg13.5	T type	Rc <sup>1</sup> / <sub>4</sub>	7/16-20UNF	G 1/2	L type	1/4-18NPT	7/16-20UNF	1/2-14NPT	L type	1/4-18NPT	M10	Pg13.5	L type	1/4-18NPT	M10	M20x1.5	L type	1/4-18NPT	7/16-20UNF	Pg13.5	L type																		
<Process connection>	<Oval flange screw>	<Conduit connection>	<Case type>																																																												
Rc <sup>1</sup> / <sub>4</sub>	7/16-20UNF	G 1/2	T type																																																												
1/4-18NPT	7/16-20UNF	1/2-14NPT	T type																																																												
1/4-18NPT	M10	Pg13.5	T type																																																												
1/4-18NPT	M10	M20x1.5	T type																																																												
1/4-18NPT	7/16-20UNF	Pg13.5	T type																																																												
Rc <sup>1</sup> / <sub>4</sub>	7/16-20UNF	G 1/2	L type																																																												
1/4-18NPT	7/16-20UNF	1/2-14NPT	L type																																																												
1/4-18NPT	M10	Pg13.5	L type																																																												
1/4-18NPT	M10	M20x1.5	L type																																																												
1/4-18NPT	7/16-20UNF	Pg13.5	L type																																																												
5	<p>&lt;Mounting flange&gt;</p> <table border="1"> <tr> <td>Material</td> <td>Size and rating</td> </tr> <tr> <td>316 stainless</td> <td>IDF standard 4" clamp</td> </tr> </table>	Material	Size and rating	316 stainless	IDF standard 4" clamp																																																										
Material	Size and rating																																																														
316 stainless	IDF standard 4" clamp																																																														
6	<p>&lt;Span limit (*1) [kPa] [m bar]&gt;</p> <p>0.32 ..... 32</p> <p>{3.2 ..... 320}</p> <p>1.3 ..... 130</p> <p>{13 ..... 1300}</p> <p>5 ..... 500</p> <p>{50 ..... 5000}</p>	Note 1																																																													
7	<p>&lt;Material&gt;</p> <table border="1"> <thead> <tr> <th colspan="2">LP side</th> <th colspan="2">HP side</th> </tr> <tr> <th>Process cover</th> <th>Diaphragm</th> <th>Wetted sensor body</th> <th>Diaphragm and flange face</th> </tr> </thead> <tbody> <tr> <td>316 stainless steel</td> <td>316L stainless steel</td> <td>316 stainless steel</td> <td>316L stainless steel</td> </tr> </tbody> </table>	LP side		HP side		Process cover	Diaphragm	Wetted sensor body	Diaphragm and flange face	316 stainless steel	316L stainless steel	316 stainless steel	316L stainless steel																																																		
LP side		HP side																																																													
Process cover	Diaphragm	Wetted sensor body	Diaphragm and flange face																																																												
316 stainless steel	316L stainless steel	316 stainless steel	316L stainless steel																																																												
9	<p>&lt;Indicator and arrester&gt;</p> <table border="0"> <tr> <td><u>Indicator</u></td> <td><u>Arrester</u></td> </tr> <tr> <td>None</td> <td>None</td> </tr> <tr> <td>Analog, 0 to 100% linear scale</td> <td>None</td> </tr> <tr> <td>Analog, custom scale</td> <td>None</td> </tr> <tr> <td>None</td> <td>Yes</td> </tr> <tr> <td>Analog, 0 to 100% linear scale</td> <td>Yes</td> </tr> <tr> <td>Analog, custom scale</td> <td>Yes</td> </tr> <tr> <td>Digital, 0 to 100% linear scale</td> <td>None</td> </tr> <tr> <td>Digital, custom scale</td> <td>None</td> </tr> <tr> <td>Digital, 0 to 100% linear scale</td> <td>Yes</td> </tr> <tr> <td>Digital, custom scale</td> <td>Yes</td> </tr> <tr> <td>Digital, 0 to 100% linear scale (Local configurator unit with LCD display)</td> <td>None</td> </tr> <tr> <td>Digital, custom scale (Local configurator unit with LCD display)</td> <td>None</td> </tr> <tr> <td>Digital, 0 to 100% linear scale (Local configurator unit with LCD display)</td> <td>Yes</td> </tr> <tr> <td>Digital, custom scale (Local configurator unit with LCD display)</td> <td>Yes</td> </tr> </table>	<u>Indicator</u>	<u>Arrester</u>	None	None	Analog, 0 to 100% linear scale	None	Analog, custom scale	None	None	Yes	Analog, 0 to 100% linear scale	Yes	Analog, custom scale	Yes	Digital, 0 to 100% linear scale	None	Digital, custom scale	None	Digital, 0 to 100% linear scale	Yes	Digital, custom scale	Yes	Digital, 0 to 100% linear scale (Local configurator unit with LCD display)	None	Digital, custom scale (Local configurator unit with LCD display)	None	Digital, 0 to 100% linear scale (Local configurator unit with LCD display)	Yes	Digital, custom scale (Local configurator unit with LCD display)	Yes																																
<u>Indicator</u>	<u>Arrester</u>																																																														
None	None																																																														
Analog, 0 to 100% linear scale	None																																																														
Analog, custom scale	None																																																														
None	Yes																																																														
Analog, 0 to 100% linear scale	Yes																																																														
Analog, custom scale	Yes																																																														
Digital, 0 to 100% linear scale	None																																																														
Digital, custom scale	None																																																														
Digital, 0 to 100% linear scale	Yes																																																														
Digital, custom scale	Yes																																																														
Digital, 0 to 100% linear scale (Local configurator unit with LCD display)	None																																																														
Digital, custom scale (Local configurator unit with LCD display)	None																																																														
Digital, 0 to 100% linear scale (Local configurator unit with LCD display)	Yes																																																														
Digital, custom scale (Local configurator unit with LCD display)	Yes																																																														
10	<p>&lt;Approvals for hazardous locations&gt;</p> <p>None (for ordinary locations)</p>																																																														
11	<p>&lt;Diaphragm extension [mm]&gt;</p> <p><u>Extension [mm]</u></p> <p>0</p>																																																														
12	<p>&lt;Options&gt;</p> <table border="0"> <tr> <td><u>Extra SS tag plate</u></td> <td><u>Stainless steel elec. housing</u></td> <td><u>Coating of cell</u></td> </tr> <tr> <td>None</td> <td>None</td> <td>None</td> </tr> <tr> <td>Yes</td> <td>None</td> <td>None</td> </tr> <tr> <td>None (*2)</td> <td>None</td> <td>Yes</td> </tr> <tr> <td>Yes</td> <td>None</td> <td>Yes</td> </tr> <tr> <td>None</td> <td>Yes</td> <td>Yes</td> </tr> <tr> <td>Yes</td> <td>Yes</td> <td>Yes</td> </tr> </table>	<u>Extra SS tag plate</u>	<u>Stainless steel elec. housing</u>	<u>Coating of cell</u>	None	None	None	Yes	None	None	None (*2)	None	Yes	Yes	None	Yes	None	Yes	Yes	Yes	Yes	Yes	Note 2																																								
<u>Extra SS tag plate</u>	<u>Stainless steel elec. housing</u>	<u>Coating of cell</u>																																																													
None	None	None																																																													
Yes	None	None																																																													
None (*2)	None	Yes																																																													
Yes	None	Yes																																																													
None	Yes	Yes																																																													
Yes	Yes	Yes																																																													
13	<p>&lt;Special applications and fill fluid&gt;</p> <table border="0"> <tr> <td><u>Treatment</u></td> <td><u>Fill fluid</u></td> </tr> <tr> <td>Degreasing</td> <td>Silicone oil</td> </tr> </table>	<u>Treatment</u>	<u>Fill fluid</u>	Degreasing	Silicone oil																																																										
<u>Treatment</u>	<u>Fill fluid</u>																																																														
Degreasing	Silicone oil																																																														

Note 1: (\*1) 100: 1 turn down is possible, but should be used at a span greater than 1/40 of the maximum span for better performance.  
 Note 2: (\*2) Customer tag number can be engraved on standard stainless steel name plate. If extra tag plate is required, select "Yes".

Digit	Description	Note	1	2	3	4	5	6	7	8	9	10	11	12	13	14	15	21	← Digit No. of code
14	<O-ring, gasket> O-ring / Gasket Teflon (gasket)		F	K	E					5							B		
15	<Bolt/nut> (*3) Cr-Mo alloy hexagon socket head cap screw/carbon steel nut Cr-Mo alloy hexagon bolt/nut 304 stainless steel bolt / nut	Note 3															A B E		
21	<Other options> High accuracy type                      Instruction manual attached Low temperature effect type            Instruction manual attached H+J    Instruction manual attached Opposite Vent/Drain Plug Position    Instruction manual attached Instruction manual unattached High accuracy type                      Instruction manual unattached Low temperature effect type            Instruction manual unattached T+U    Instruction manual unattached Opposite Vent/Drain Plug Position    Instruction manual unattached	Note 4																H J K C L T U V P	

Note 3: (\*3) In case of tropical use, select stainless bolts and nuts.  
 Note 4: If other option is not necessary, 21st digit code is blank.

## ORDERING INFORMATION

When ordering this instrument, specify:

1. CODE SYMBOLS
2. Measuring range
3. Output orientation (burnout direction) when abnormality is occurred in the transmitter.  
 Hold / Overscale / Underscale.  
 Unless otherwise specified, output hold function is supplied.
4. Indication method (indicated value and unit) in case of the actual scale (code D, H, P, S on 9th digit).
5. TAG No. (up to 14 alphanumerical characters), if required.

# OUTLINE DIAGRAM (Unit:mm)

<Amp. case:T type>

4th digit of the code symbols	conduit conn.			Press. Conn.	Oval flange screw
	D	E	F	H	
5	G1/2	18	2	Rc 1/4	7/16-20UNF SCREW DEPTH15
6	1/2-14NPT	16	4	1/4-18NPT	7/16-20UNF SCREW DEPTH15
7	Pg13.5	10.5	4.5	1/4-18NPT	M10 SCREW DEPTH15
8	M20×1.5	16	4	1/4-18NPT	M10 SCREW DEPTH15
9	Pg13.5	10.5	4.5	1/4-18NPT	7/16-20UNF SCREW DEPTH15

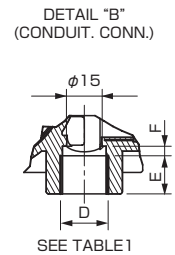
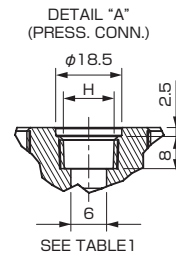
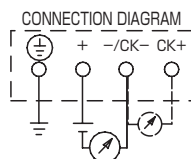
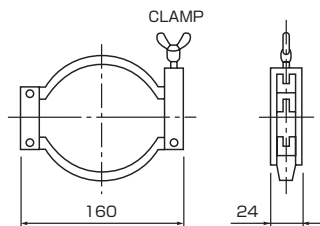
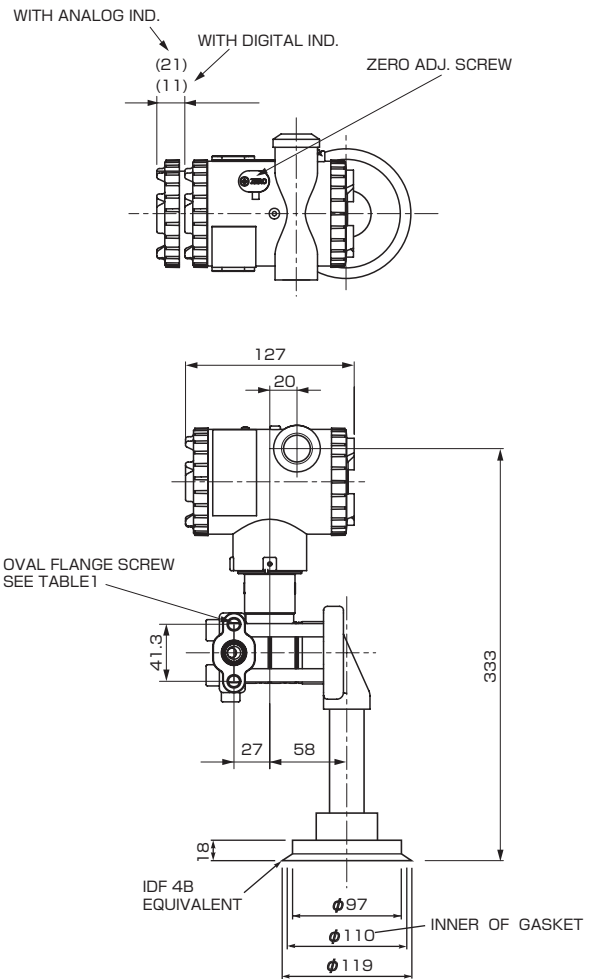
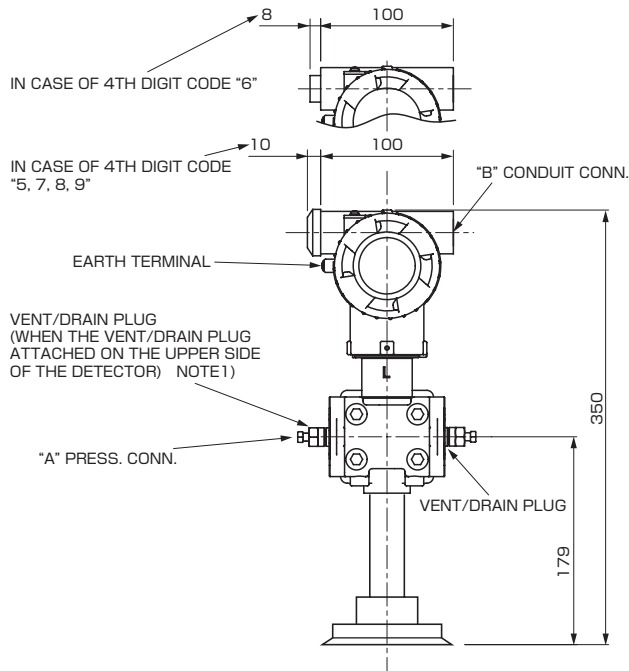

NOTE1) THE PRESSURE CONNECTOR IS LOCATED ON THE DOWN SIDE SURFACE OF THE DETECTOR, WHEN THE VENT/DRAIN PLUG IS ATTACHED ON THE UPPER SIDE OF THE DETECTOR (WHEN THE 21ST DIGIT OF THE CODE SYMBOLS : C,P).

# OUTLINE DIAGRAM (Unit:mm)

<Amp. case: L type>

4th digit of the code symbols	conduit conn.			Press. Conn.	Oval flange screw
	D	E	F	H	
S	G1/2	18	2	Rc 1/4	7/16-20UNF SCREW DEPTH15
T	1/2-14NPT	16	4	1/4-18NPT	7/16-20UNF SCREW DEPTH15
V	Pg13.5	10.5	4.5	1/4-18NPT	M10 SCREW DEPTH15
W	M20x1.5	16	4	1/4-18NPT	M10 SCREW DEPTH15
X	Pg13.5	10.5	4.5	1/4-18NPT	7/16-20UNF SCREW DEPTH15

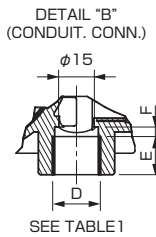
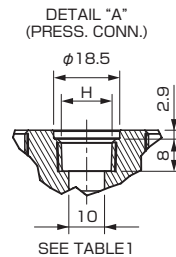
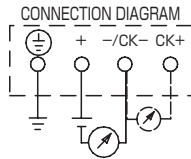
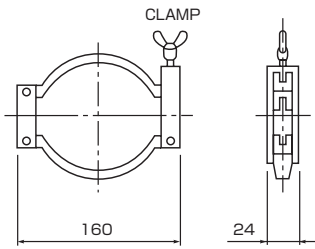
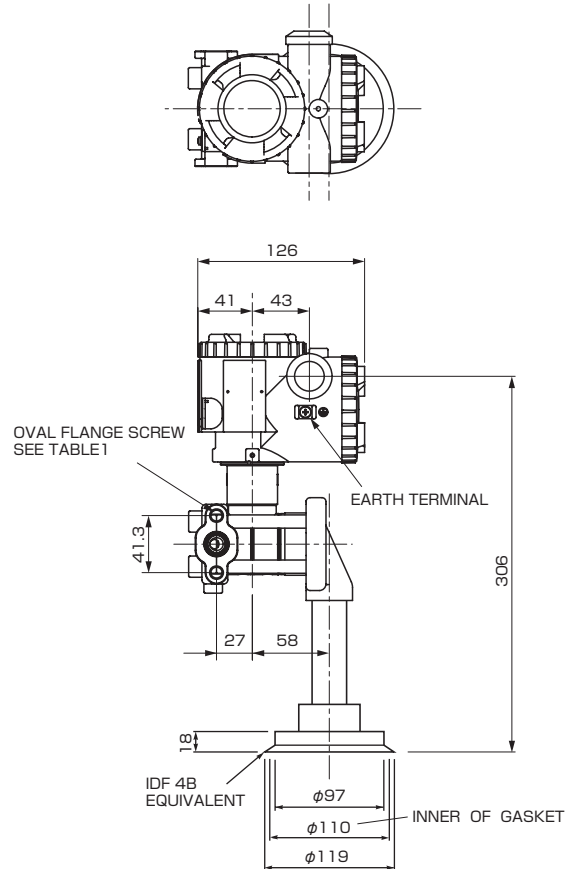
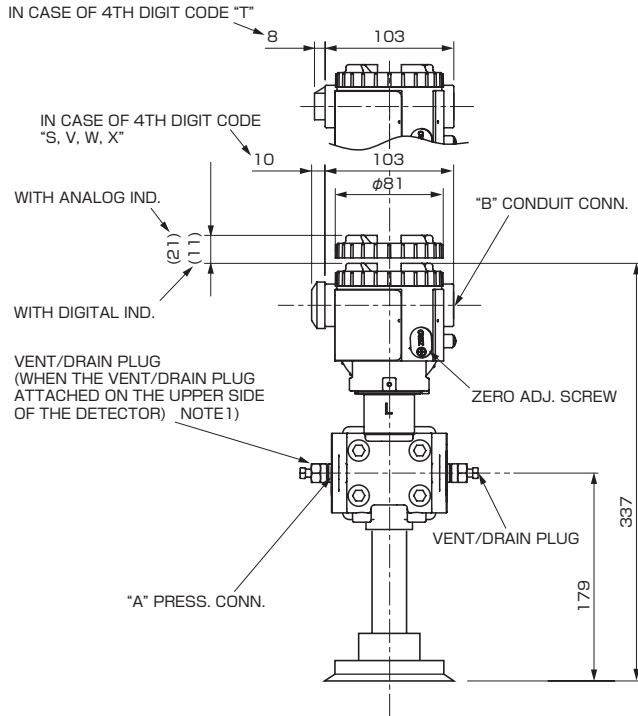

NOTE 1) THE PRESSURE CONNECTOR IS LOCATED ON THE DOWN SIDE SURFACE OF THE DETECTOR, WHEN THE VENT/DRAIN PLUG IS ATTACHED ON THE UPPER SIDE OF THE DETECTOR (WHEN THE 21ST DIGIT OF THE CODE SYMBOLS : C.P).

⚠ Caution on Safety

\*Before using this product, be sure to read its instruction manual in advance.

## Fuji Electric Systems Co.,Ltd.

International Sales Div.1

Sales Group

Gate City Ohsaki, East Tower, 11-2, Osaki 1-chome,  
Shinagawa-ku, Tokyo 141-0032, Japan

<http://www.fesys.co.jp/eng>

Phone: 81-3-5435-7280, 7281 Fax: 81-3-5435-7425

<http://www.fic-net.jp/eng>