

MAINTENANCE MANUAL
FOR
FCX-AII SERIES TRANSMITTER
(FCX-AII, AIIe)

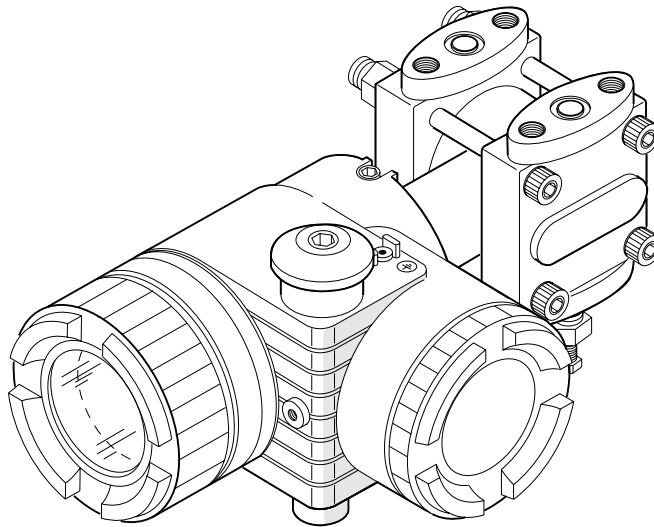

CONTENTS

1. PERIODIC INSPECTION	1
2. TROUBLESHOOTING	2
3. REPLACEMENT OF PARTS	8
4. ADJUSTMENT AFTER REPLACEMENT OF UNIT	15

APPENDIX

A1. ADJUSTMENT	16
A1.1 Adjustment with HHC	16
A1.2 Adjustment by the screw	35
A2. CALIBRATION	36
A3. BUILT-IN ARRESTER	38

1. PERIODIC INSPECTION

In order to ensure the measurement accuracy and long life of the transmitter, it is essential to inspect the transmitter periodically according to the operating conditions.

Visual inspection

Visually inspect each part of the transmitter for damage, corrosion, etc.

If you detect any material which may cause corrosion, it should be cleaned off.

Check of cover and O-ring

The transmitter has a water and dust-proof construction.

Make sure the O-ring of the case cover is not damaged or deteriorated.

Carefully prevent foreign materials from sticking to threads.

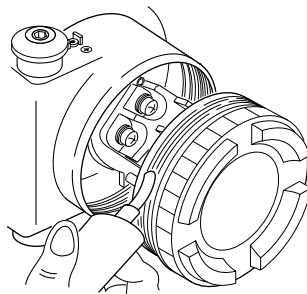

Piping leakage check

Using soapy water or the like, check the all process connections for leakage of process fluid. If necessary, drain the moisture which has accumulated in the transmitter and process pipe.

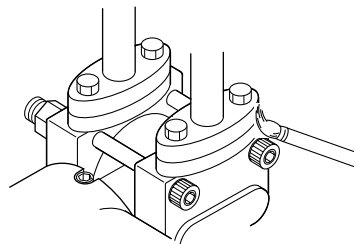

2. TROUBLESHOOTING

When a problem occurs, use the following troubleshooting steps:

1. In case the Hand Held Communicator (HHC) can be connected to the transmitter:
First use the self check function to get the diagnostic message. If diagnostic messages appear, take actions according to Table 2.
Second check the configuration data such as:
 - Range
 - Damping
 - Output mode (linear or square-root output)
 - Measurement digital data output
2. Check for faulty electrical wiring/connections or piping connections. Check for leaks and damage.
3. Use the fixed current output function to perform a loop check at 4 to 20mA. check that its output signal is correct and that the signal is being received at its destination point in the loop and in the control room.
4. Isolate the transmitter from the process, vent and drain the unit. Check the zero output. If the output is correct, the problem will usually be found in the piping or process conditions.
5. Check the transmitter's range settings and calibration.
6. Check for process conditions, such as sediment, trapped gas or liquid, or a density change.
7. If you have a spare electronics unit, replace the electronics unit to determine whether the fault is in the electronics unit or the detecting unit. When the fault disappears after replacing the electronics unit, the electronics unit should have the problem. When the fault still exists after replacing the electronics unit, the electronics housing (with terminal unit) or the detecting unit should have the problem.
8. Change the electronics housing to new one. When the fault disappears, the electronics housing should have the problem. When the fault still exists after replacing the electronics housing, the detecting unit should have the problem.

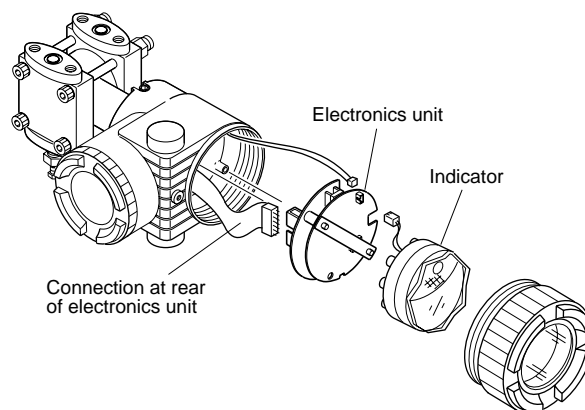

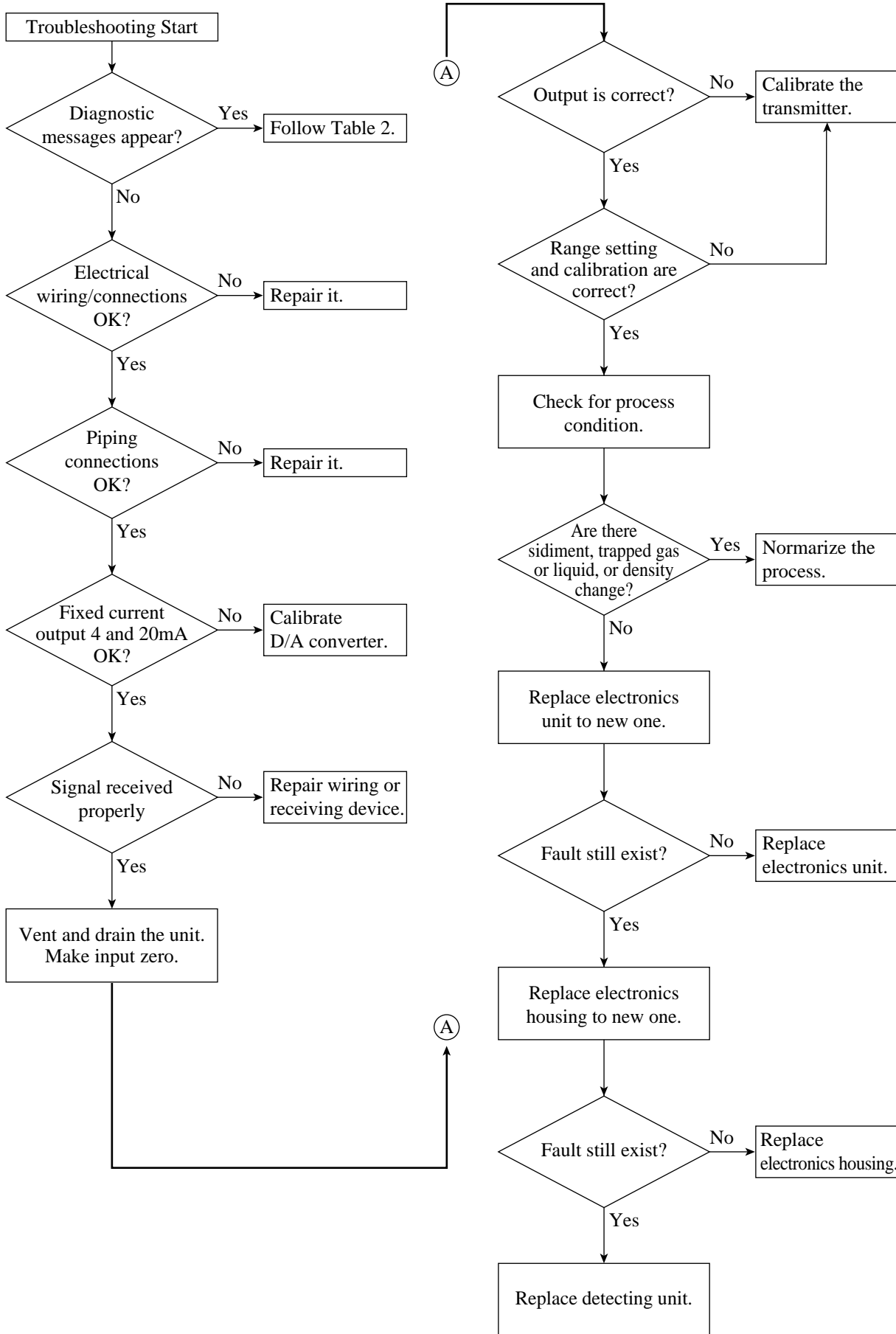

Table 1 Output problem

Problem	Probable Cause	Corrective Action
High output (exceeds 20mA)	Pressure piping	Check for leaks or clogging.
		Check that blocking valves are fully open.
		Check for entrapped gas in liquid lines and for liquid in dry lines.
		Check that the density of the fluid in the pressure lines is unchanged.
		Check for sediment in the transmitter process cover.
	Power supply	Check power supply voltage is proper.
	Loop wiring	Check load resistance is proper.
		Check for shorts and open circuit.
	Zero and span incorrect	Calibrate transmitter.
	Built-in arrester faulty (If used)	Check arrester. Refer to “A5. BUILT-IN ARRESTER”.
	Burnout mode Transmitter detected its critical failure and went into Burnout mode. (In case Burnout set to Over Scale)	Do self check function and take actions according to the diagnostic messages. (Refer to Table 2.)
Electronics unit faulty	Replace electronics unit.	
Detecting unit faulty	Replace detecting unit.	
Low output or No output (less than 3.8mA)	Pressure piping	Check for leaks or clogging.
		Check that blocking valves are fully open and that equalizing valves are tightly closed.
		Check for entrapped gas in liquid lines and for liquid in dry lines.
		Check that the density of the fluid in the pressure lines is unchanged.
		Check for sediment in the transmitter process cover.
	Power supply	Check power supply voltage and/or polarity are proper.
	Loop wiring	Check load resistance is proper.
		Check for shorts and open circuit.
	Zero and span incorrect	Calibrate transmitter.
	Burnout mode Transmitter detected its critical failure and went into Burnout mode. (In case Burnout set to Under Scale)	Do self check function and take actions according to the diagnostic messages. (Refer to Table 2.)
	Electronics unit faulty	Replace electronics unit.
Detecting unit faulty	Replace detecting unit.	

Table 1 Output problem (continued)

Problem	Probable Cause	Corrective Action
Erratic Output	Pressure piping	Check for leaks or clogging.
		Check that blocking valves are fully open and that equalizing valves are tightly closed.
		Check for entrapped gas in liquid lines and for liquid in dry lines.
		Check that the density of the fluid in the pressure lines is unchanged.
		Check for sediment in the transmitter process cover.
	Loop wiring	Check load resistance is proper.
		Check for intermittent shorts and open circuit.
	Process fluid pulsation	Increase damping.
	Ambient temperature changes widely.	Minimize temperature change effects.
	Built-in arrester faulty (If used)	Check arrester. Refer to "A5. BUILT-IN ARRESTER".
	Gas generated inside detecting unit (Ex. Discharged gas due to excessive high temp or hydrogen penetration)	Replace detecting unit.
	Filled oil leakage	Replace detecting unit.
	Zero and span incorrect	Calibrate transmitter.
Amplifier unit faulty	Replace amplifier unit.	
Detecting unit faulty	Replace detecting unit.	
Fixed Output (Output does not respond to input pressure.)	Pressure piping	Check for leaks or clogging.
		Check that blocking valves are fully open and that equalizing valves are tightly closed.
		Check for entrapped gas in liquid lines and for liquid in dry lines.
	Fixed output mode	See digital indicator to check output mode if available. In case of analog type, check mode setting switch on amplifier unit is not in fixed current output mode position. In case of smart type, once perform fixed output function by using HHC and then return the transmitter to measurement mode.
	Filled oil leakage	Replace detecting unit.
	Burnout mode Transmitter detected its critical failure and went into Burnout mode. (In case Burnout set to Not Used)	Do self check function and take actions according to the diagnostic messages. (Refer to Table 2.)
	Amplifier unit faulty	Replace amplifier unit.
Detecting unit faulty	Replace detecting unit.	

Table 2 Diagnostic Messages

Message	XMTR LCD	Burnout Mode	Probable Cause	Corrective Action
<p>NO CONNECTION (No response from transmitter)</p> <p>or</p> <p>SIGNAL ERROR (Response from transmitter is illegal.)</p>	—	No	Communication module disconnected.	Make sure communication module is mounted on the Amplifier unit properly.
			HHC not connected properly.	Check the connection. Refer to “Connection of HHC” in Section A3.
			Short or open in communication wire.	Perform a continuity check to determine if a short or open exist.
			Transmitter doesn’t have a minimum of 11V DC at its terminal.	Correct power problem.
			Load resistance in the loop is less than 250Ω.	Increase the load resistance to at least 250Ω.
			Excessive capacity or inductance in the loop.	Check capacitive or inductive devices (Filters) meet to the requirement for communication. Load capacitance : 0.22μF max. Load inductance : 3.3mH max.
			Excessive line noise	Check line noise. Use an oscilloscope to determine if the line noise is excessive.
<p>TYPE CODE NOTHING</p>	FL-1 or FL-3	Yes	Ribbon cable between amplifier unit and detecting unit disconnected.	Make sure amplifier unit is connected to detecting unit with ribbon cable properly. Check for damages on the ribbon cable.
	—	No	Memory problem on detecting unit	Contact Fuji technical support.
<p>CELL FLT (C1) (C1 signal from sensor element cannot be read.)</p> <p>or</p> <p>CELL FLT (C2) (C2 signal from sensor element cannot be read.)</p> <p>or</p> <p>CELL FLT (C3) (C3 signal from detecting unit cannot be read.)</p> <p>or</p> <p>CELL FLT (C4) (Signal from temp. sensor cannot be read.)</p>	FL-1	Yes	Ribbon cable between amplifier unit and detecting unit disconnected.	Make sure amplifier unit is connected to detecting unit with ribbon cable properly. Check for damages on the ribbon cable.
			Failure in detecting unit	Replace detecting unit.

Table 2 Diagnostic Messages (continued)

Message	XMTR LCD	Burnout Mode	Probable Cause	Corrective Action
XMTR FLT	FL-1	Yes	Characterization data in detecting unit abnormal	Replace detecting unit.
EEPROM (AMP) FLT	FL-2	Yes	Access to amplifier unit's EEPROM impossible	Replace amplifier unit.
EEPROM (CELL) FLT	FL-3	Yes	Ribon cable between amplifier unit and detecting unit disconnected.	Make sure amplifier unit is connected to detecting unit with ribbon cable properly. Check for damages on the ribbon cable.
			Access to detecting unit's EEPROM impossible	Replace detecting unit.
TMP ALM	Flashing colon (:)	No	Temperature inside detecting unit exceeds operating limit.	Remove the source of extreme temperature.
			Failure in temp. sensor	Replace detecting unit.
OVERLOAD	OVER	No	Input pressure exceeds 160% of URL.	If process pressure exceeds the transmitter's overrange rating, normalize process pressure.
	UNDR	No	Input pressure exceeds 160% of URL reversely.	

3. REPLACEMENT OF PARTS

If the transmitter requires a replacement part, drain process fluid from the transmitter, disconnect it from the process and carry out replacement in an instrument room.



DANGER

When removing an explosion-proof transmitter, turn OFF the main power, then disconnect the piping and wiring. Do not remove it when the power is ON to prevent serious accident such as explosion, fire, etc.

To identify faulty part

Replace the electronics unit with a spare one in order to determine whether it is the detecting unit or electronics unit which is faulty.

When the faulty unit is identified, it should be replaced with a new one.

Replacement of electronics unit

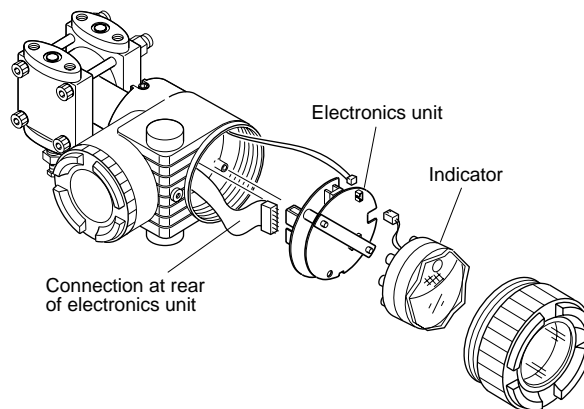

Replacing procedure

- (1) Turn off the power supply.
- (2) Remove the indicator.
- (3) Remove the electronics unit.
Unplug each connector.
- (4) Remove the stud bolts which fastens the indicator.
- (5) Replace the electronics unit with a new one and assemble it by reversing the above procedure from (4) to (1).



Important

When installing the electronics unit, make sure that the zero/span adjust screw and the volume control are positioned as shown the right.

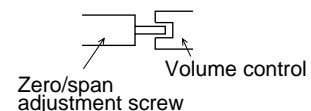

- (6) After completion of replacement, perform zero and span adjustments.



Important

The electronics unit should be removed carefully so as not to damage the internal wiring.

Replacement of detecting unit

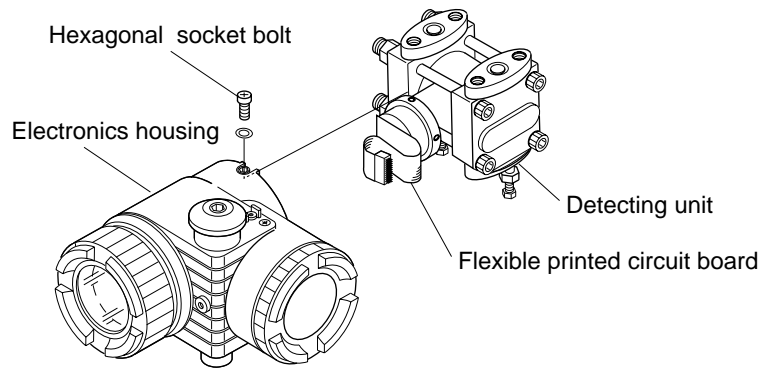

Replacing procedure

- (1) Remove the electronics unit according to “Replacement of electronics unit.”
- (2) Remove the hex. socket bolts from the electronic housing.
Pull the electronics housing straight forward and away from the detecting unit.
- (3) Replace the detecting unit with a new one of the same type.
- (4) Fit the electronics housing to the detecting unit and tighten it.
- (5) Connect each connector of the electronics unit and attach it to the electronics housing.
- (6) After reassembly, carry out zero and span adjustments.



Important

- Ensure that replacement detecting unit is the same specification as the original by comparing dataplates.
- When removing the electronics housing, pay attention not to damage the flexible PC board.

Replacement of the internal parts of detecting unit

In case of differential and flow transmitter (code symbol: FHC/FKC):

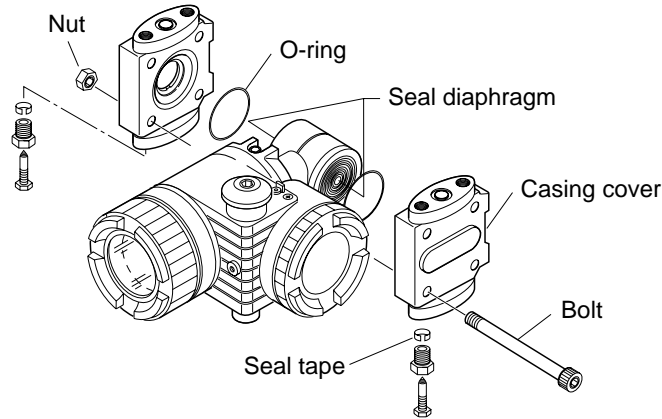

— Replacing procedure —

- (1) Remove four hexagon socket head bolts with a torque wrench, etc..
- (2) Disassembly gives access to the casing covers, O-rings, hexagon socket head bolts and nuts.
- (3) After disassembly, replace the faulty part with a new one.
- (4) Before reassembly, clean the O-ring face of casing cover with the soft cloth immersed in water, alcohol, or similar detergent, and change the O-ring to new one.
- (5) Reassemble the detecting unit by reversing the disassembling procedure. The casing covers should be assembled so as to be symmetrical with each other in the left-right direction and carefully so as not to damage the seal diaphragm. Tightening torque should follow the table below.

Bolt size	Bolt material	Tightening torque [N•m] (kgf•m) <ft-lb>	Maximum working pressure [MPa] {bar} <psi>	Application
M10	Cr-Mo steel	50 (5) <36>	42 {420} <6000>	Working pressure 42 MPa {420 bar} <6000 psi> or less
M10	SUS304 ASTMB7M ASTML7M	30 (3) <22>	10 {100} <1400>	Working pressure 10MPa {100 bar} <1400 psi> or less
M10	SUS630	50 (5) <36>	42 {420} <6000>	Working pressure 42 MPa {420 bar} <6000 psi> or less

- (6) After assembly, carry out a pressure test. Apply a pressure equal to 150% of the maximum working pressure to both high pressure (H) and low pressure (L) measurement chambers of the transmitter simultaneously for 15 minutes, and make sure there is no leakage.

In case of absolute pressure and gauge pressure transmitter (code symbol: FKA and FHG/FKG):

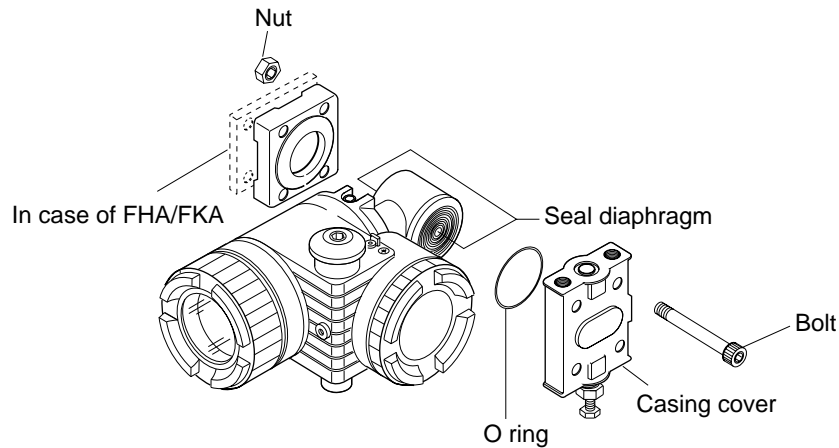

- (1) Remove four bolts with a torque wrench, etc..
- (2) Disassembly gives access to casing covers, O-rings, bolts and nuts.
- (3) After disassembly, replace the faulty part with a new one.
- (4) Before reassembly, clean the O-ring face of casing cover with the soft cloth immersed in water, alcohol, or similar detergent, and change the O-ring to new one.
- (5) Reassemble the detecting unit by reversing the disassembling procedure. The casing covers should be assembled so as to be symmetrical with each other in the left-right direction and carefully so as not to damage the seal diaphragm. Tightening torque should follow the table below.

In case of absolute pressure transmitter (FKA):

Bolt size	Bolt material	Tightening torque [N•m] (kgf•m) <ft-lb>	Maximum working pressure [kPa] {bar abs} <psi>	Application
M10	Cr-Mo steel	50 (5) <36>	3000 {30} <430>	Common over entire range
M10	SUS304 ASTMB7M ASTML7M	30 (3) <22>	3000 {30} <430>	

In case of gauge pressure transmitter (FHG/FKG):

Bolt size	Bolt material	Tightening torque [N•m] (kgf•m) <ft-lb>	Maximum working pressure [kPa] {bar} <psi>	Application
M10	Cr-Mo steel	50 (5) <36>	50000 {500} <7100>	Common over entire range
M10	SUS304 ASTMB7M ASTML7M	30 (3) <22>	10000 {100} <1400>	Range 10000 [kPa] <1400 psi> or less
M10	SUS630	50 (5) <36>	50000 {500} <7100>	Exclusive for range 50000 [kPa]

- After assembly, carry out a pressure test.
Apply a pressure equal to 150% of the maximum working pressure to the high pressure (H) measurement chamber of the transmitter for 15 minutes, and make sure there is no leakage.

In case of level transmitter (code symbol: FKE):

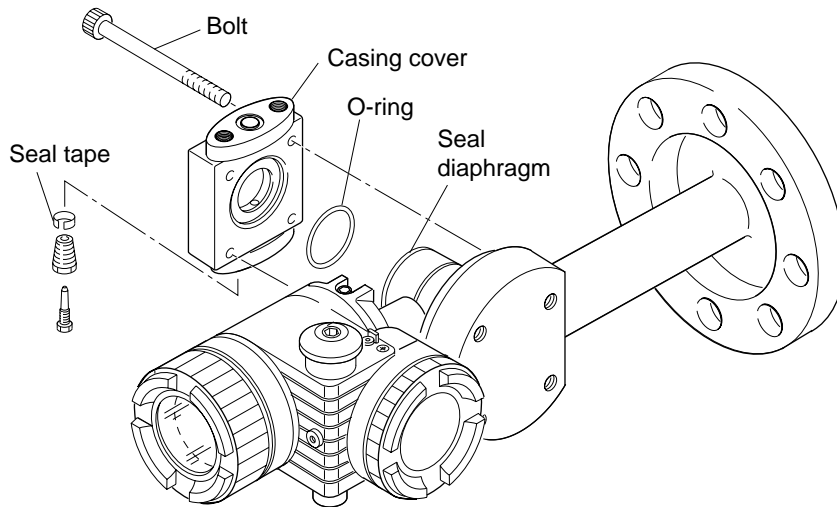

- (1) Remove four hexagon socket head bolts with a torque wrench, etc..
- (2) Disassembly gives access to the casing cover, O-ring and hexagon socket head bolts.
- (3) After disassembly, replace the faulty part with a new one.
- (4) Before reassembly, clean the O-ring face of casing cover with the soft cloth immersed in water, alcohol, or similar, and change the O-ring to new one.
- (5) Reassemble the detecting unit by reversing the disassembling procedure. The casing cover should be assembled carefully so as not to damage the seal diaphragm. Tightening torque should follow the table below.

Bolt size	Bolt material	Tightening torque [N•m] (kgf•m) <ft-lb>	Maximum working pressure
M10	Cr-Mo steel	50 (5) <36>	Up to rated flange oressure
M10	SUS304	30 (3) <22>	Up to rated flange pressure

- (6) After assembly, carry out a pressure test. Apply a pressure equal to 150% of the maximum working pressure to both flange side (high pressure side) and low pressure (L) measurement chamber of the transmitter simultaneously for 15 minutes, and make sure there is no leakage.

Replacement of field indicator

1. Replacement of analog indicator

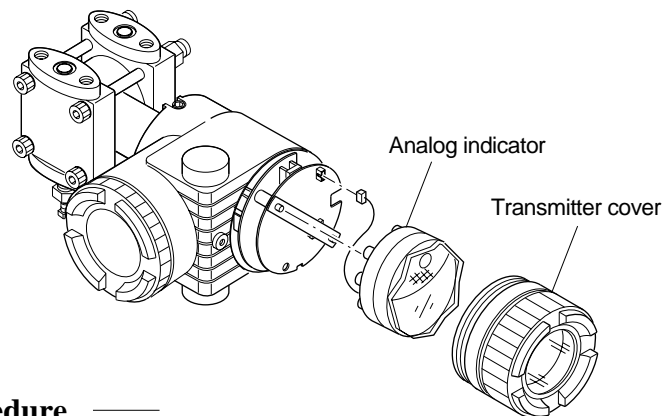

Replacing procedure

- (1) Detach the transmitter cover.
- (2) Remove the analog indicator.
- (3) Pull out the connector extending from the analog indicator.
- (4) Connect the connector of a new analog indicator to the electronics unit. (See the figure below.)
- (5) Then, mount the analog indicator at the electronics unit.

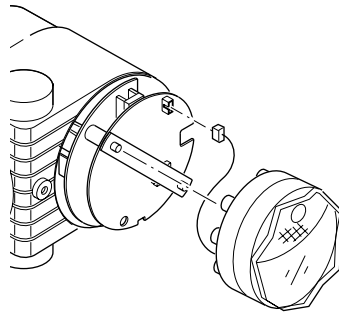

- (6) Attach the transmitter cover.

2. Replacement of digital indicator

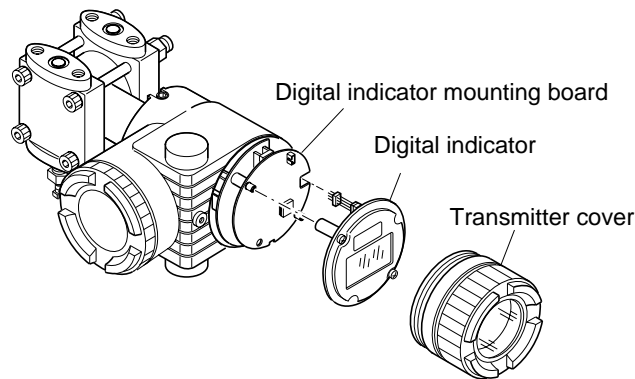

Replacing procedure

- (1) Detach the transmitter cover.
- (2) Remove two fixing screws which fasten the digital indicator and separate the indicator.
- (3) Pull out the leading end of the flexible PC board extending from the digital indicator after raising the slider (white knob) in the electronics section. (See the figure below.)
- (4) Insert the leading end of the flexible PC board of a new digital indicator into the connector plug-in port of the electronics section and fix it by pushing in the slider. Before inserting the flexible PC board, confirm its correct orientation.
- (5) Fasten the digital indicator to the electronics section by tightening two fixing screws.

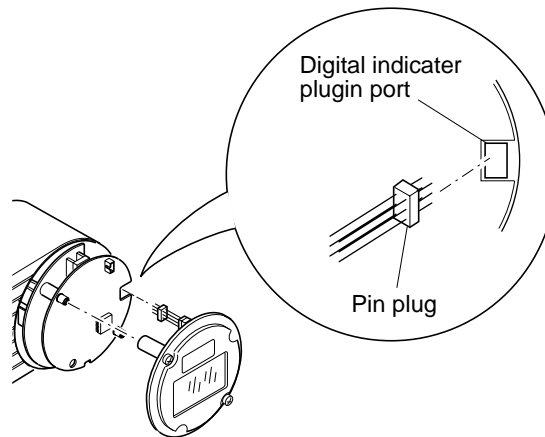

Before tightening, make sure a small recess on the surface is positioned at the top as shown below.

When twisting the flexible PC board for mounting, adequate attention should be paid not to damage the board.

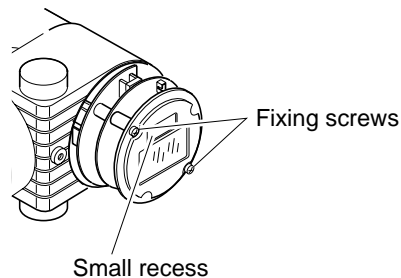

- (6) Attach the transmitter cover.

4. ADJUSTMENT AFTER REPLACEMENT OF UNIT

Adjustment

After completion of the assembly work mentioned above, use the following procedures for adjustment and setting.

Adjustment should be performed using the HHC.

(1) After replacement of electronics unit (including replacement of internal parts)

Step	Adjustment item	Relevant page
1	Constant current output (output circuit)	P25
2	TAG. No.	P17
3	Type	P18
4	Industrial value unit	P19
5	Range (zero/span)	P20
6	Zero/span adjustment	P24
7	Damping	P21
8	Output mode (LIN/ $\sqrt{\quad}$ selection)	P22
9	Burnout direction	P23
10	Lock of adjustment function	P28

(2) After replacement of detecting unit (including replacement of internal parts)

Step	Adjustment item	Relevant page
1	Range (zero/span)	P20

A1. ADJUSTMENT

When the transmitter is of the smart type, the HHC is used for each adjustment.

A1.1 Adjustment with HHC

Startup and usage of the Hand Held Communicator (HHC) are detailed in the instruction manual for HHC. Please refer to this manual before commencing adjustment.



After adjustment of the transmitter, it should be kept energized for about 10 seconds to write the adjustment results into memory.

Connection of HHC

The HHC can be connected to the transmitter, junction terminal or the terminals in the instrument room.

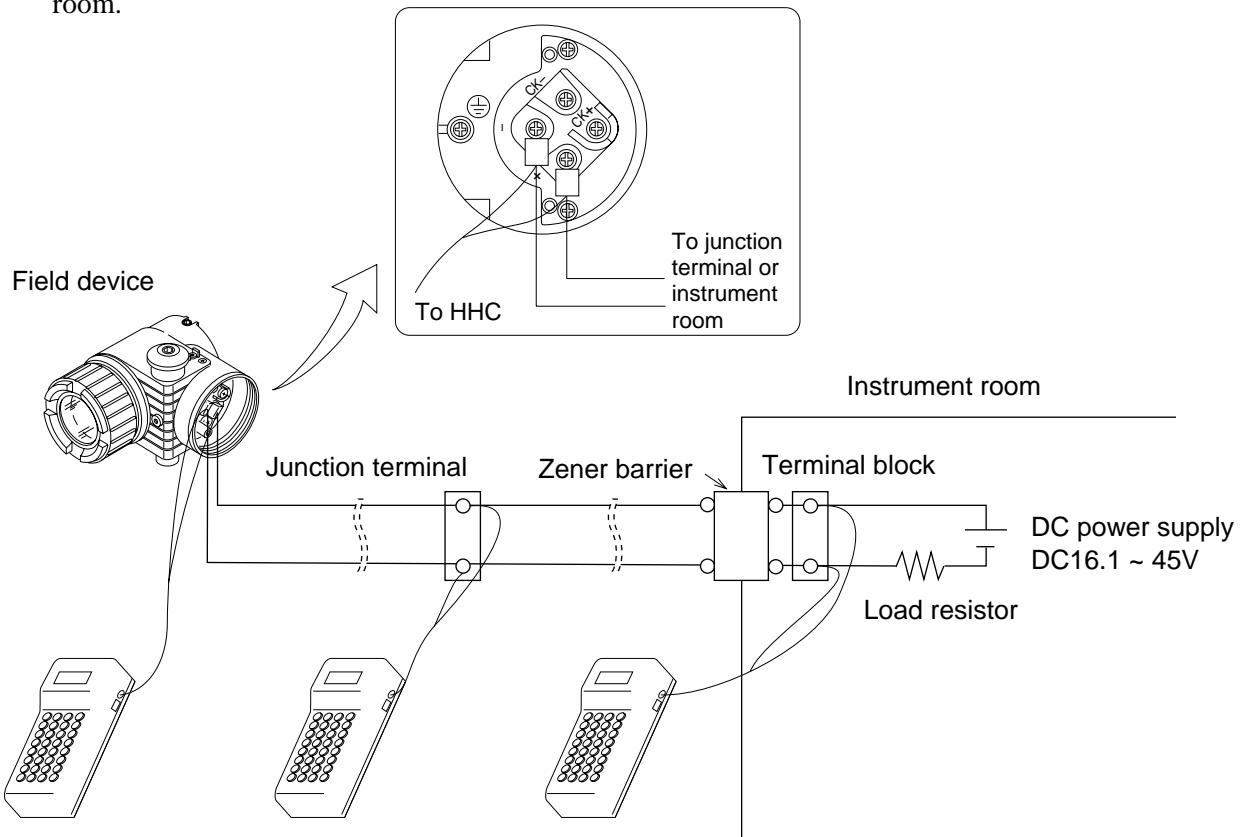

DANGER

In the case of a flameproof transmitter, never connect the HHC to the terminal block of the transmitter in hazardous area installations.

Operating procedure

In case of a flameproof transmitter, never connect the HHC to the terminal block of transmitter in hazardous area installations.

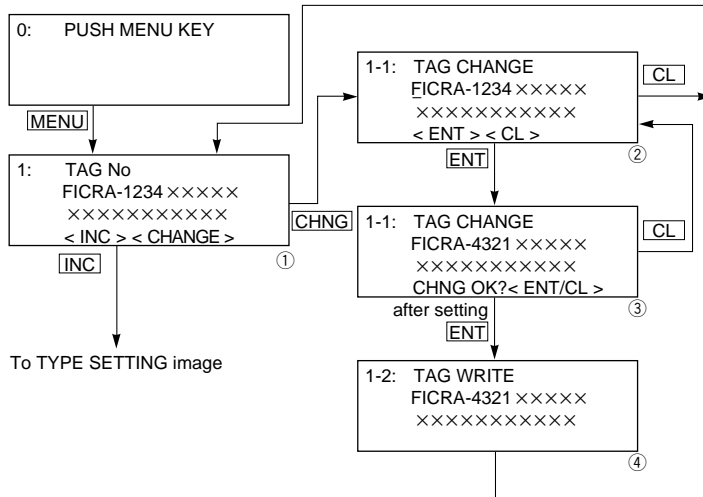

TAG NO.

To set the TAG NO. of each field device, use the procedures shown in the following diagram. TAG NO. can be inputted up to 26 character of alphanumeric codes.

- After PUSH MENU KEY is displayed, press the <MENU> key to display TAG NO.
- To make changes press the <CHNG> key and the cursor will be displayed under display ①.
- Set the alphanumeric keys as necessary under display ②.
To set the alphabet, press the <CHNG ALHA> key first.
Using <◀><▶> keys, cursor position can be moved.
- At the completion of setting, press the <ENT> key and a prompt is displayed check entry under display ②.
- If the entry is correct, press the <ENT> key to input it to the field device under display ③ and ④ and the initial image ① is displayed.
- To display TYPE display, press the <INC> key under display ①.

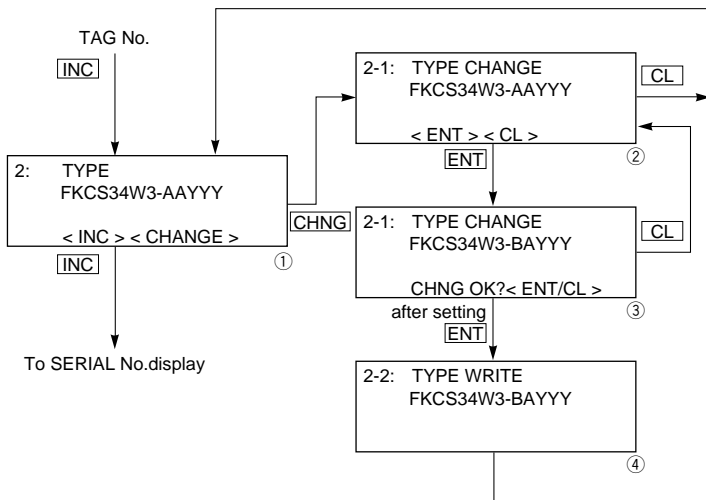

TYPE

Type of field device is displayed and changed (example of differential pressure transmitter).

- After TAG NO. is displayed, press the <INC> key to display TYPE image.
- To make changes press the <CHNG> key under display ① and the cursor will be displayed under display ②.
- Set the alphanumeric keys as necessary under display ②. To set the alphabet, press the <CHNG ALHA> key first. Using <◀><▶> keys, cursor position can be moved.
- At the completion of setting, press the <ENT> key and a prompt is displayed check entry under display ③.
- If the entry is correct, press the <ENT> key to input it to the field device under display ③ and ④ and the initial image ① is displayed.
- To display SERIAL NO., press the <INC> key under display ①.

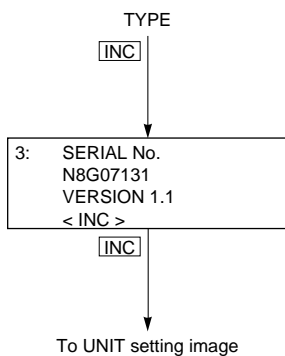

Display of SERIAL NO.

SERIAL NO. and transmitters software version are displayed.

- After setting TYPE, press the <INC> key to display SERIAL NO. and software version of transmitter.
- By pressing the <INC> key, UNIT setting image is displayed.

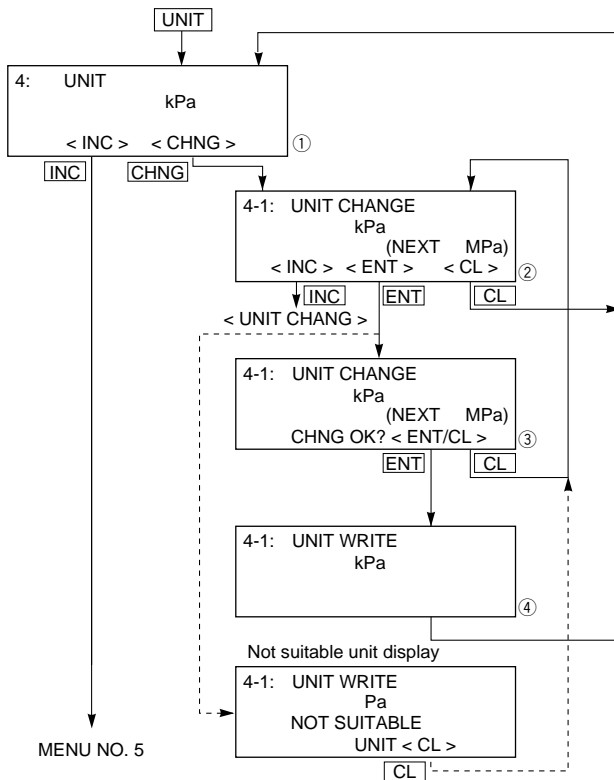

Industrial value unit

Available unit for FCX-AII

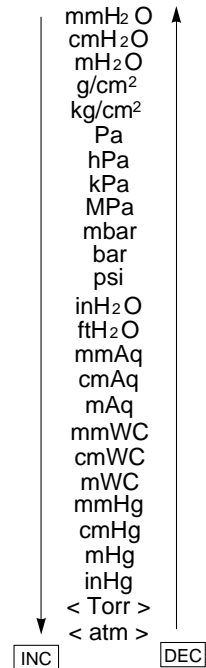

Note: The mark < > is settable for absolute pressure transmitter only.

- When pressing <CHNG> under display ①, the display for changing the unit of industrial value ② appears.
- The desired unit of industrial value is selectable by using <INC> or <DEC> under display ②.
- Display ③ is provided for confirming your change.
- Display ④ is for registering the unit of industrial value.

Important

The unit of industrial value is set according to the range as ordered, but the display resolution lowers depending on the unit being set.

When

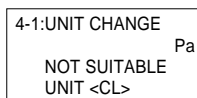

is displayed upon changing the unit of industrial value, output cannot be displayed in the engineering unit selected.

In this case, press the **CL** key and change the engineering unit to a different one.

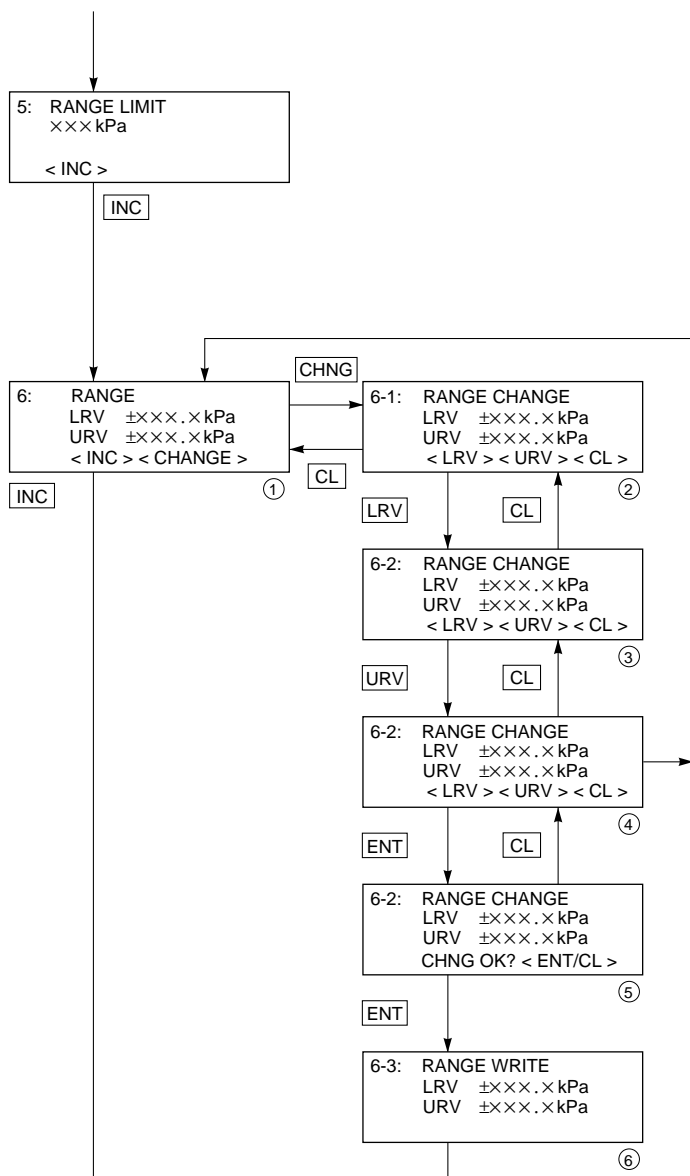

Range limit

Indicates the maximum measuring range of this transmitter.

Range change (LRV, URV)

LRV: Lower range value (0% point)
URV: Upper range value (100% point)

- When pressing <CHNG> under display ①, display changes to the LRV and URV selection screen.

Press <LRV> for presenting the display for setting the zero point range (display ③), or <URV> for presenting the display for setting the span range (display ④).

- Under displays ③ and ④, input zero point and span values.

* Press <ENT> after setting LRV and URV.

- When pressing <+/-> under display ③, ④, negative value is available.

Selectable setting range

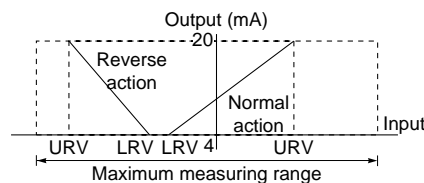

Important

In case of the actual scale specification with a digital indicator provided, if the range is changed, indicator display does not match. So, setting is required again in response to the display in the digital indicator (G: XMTR DISPLAY). In case of the actual scale specification with an analog indicator provided, if the range is changed, indicator display does not match. So, replacement of the analog indicator is required.

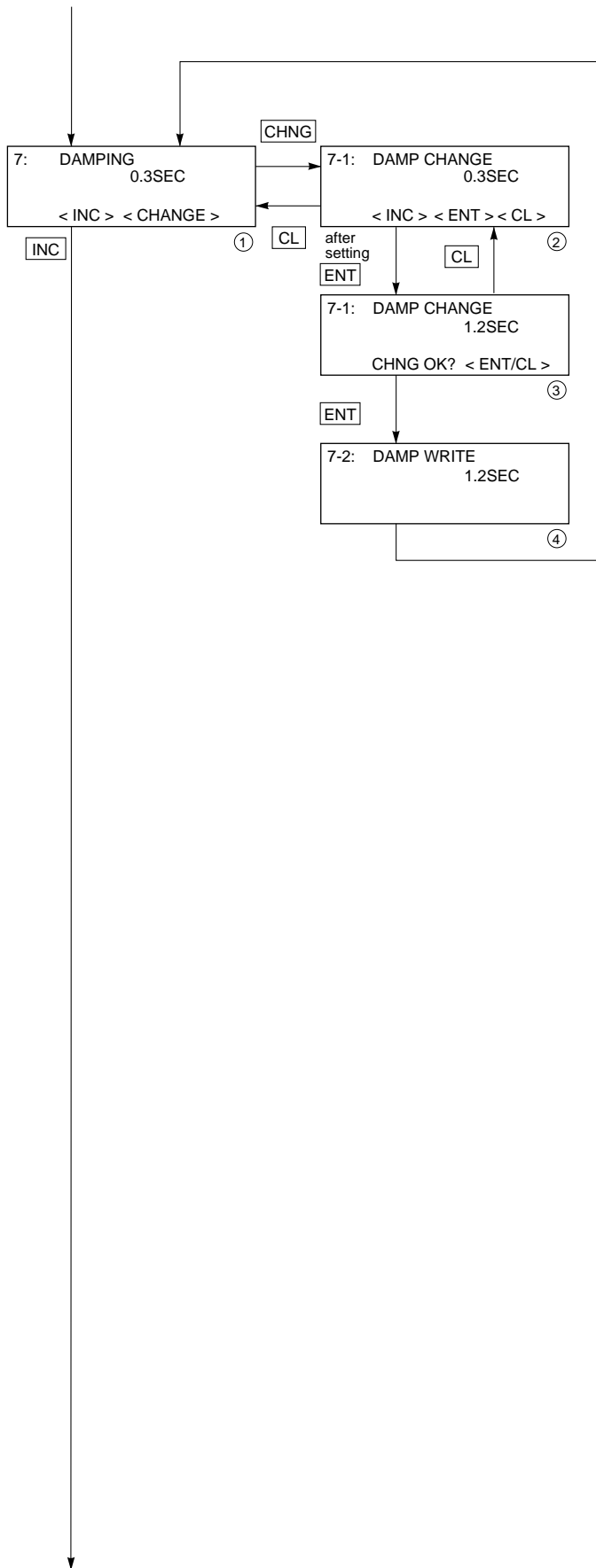

Damping adjustment

When process input changes excessively, an appropriate damping time constant should be set.

Input time constant value under display ②, time constant can be changed.

Selectable time constant value

No damping (=measuring period) to 32 sec

Note) The above damping constants are used only for the electronics unit. The detecting unit has its own constants independent of the electronics unit (for details, refer to the data sheet).

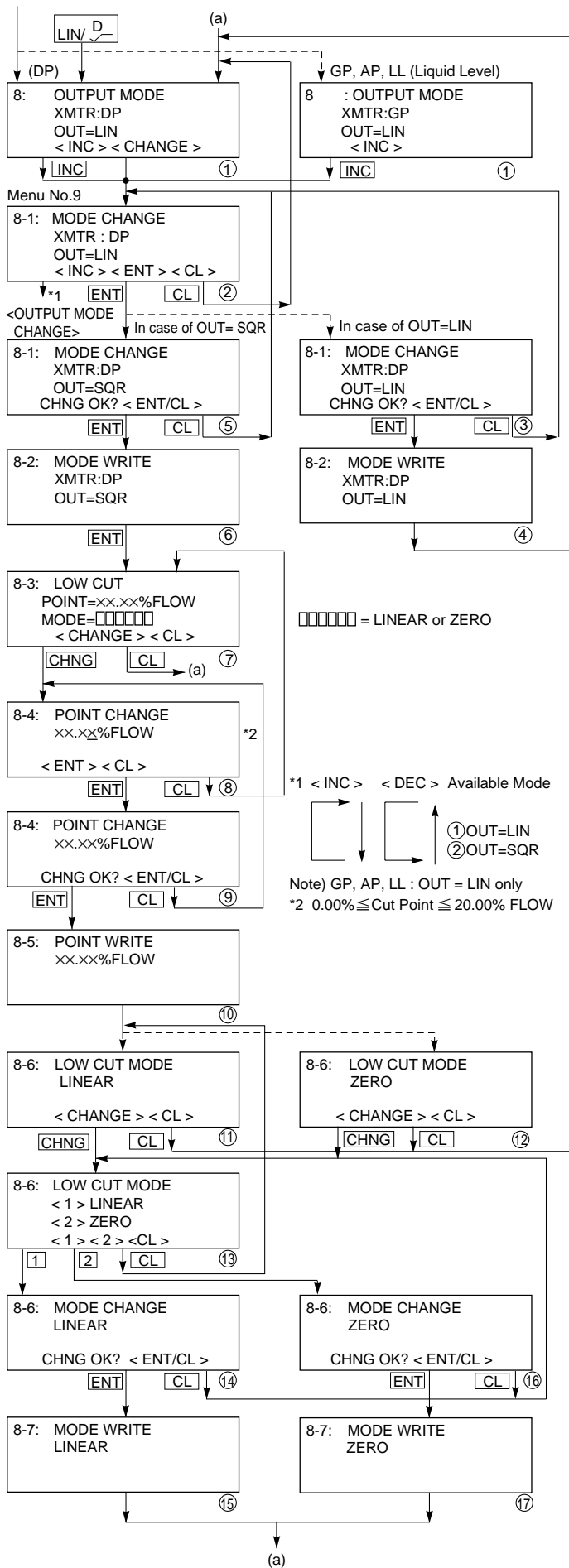

Output mode

The output mode is used to select the proportional mode (proportional to input differential pressure) or square root extraction mode (proportional to flow rate) for output signal (4 to 20 mA). In case of square root extraction mode, the cut point and the mode below the cut point can be set. Under display ②, press <INC> or <DEC> for selection of the square root extraction mode or proportional mode.

Change of output mode

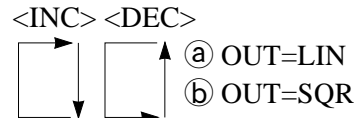

Since display ⑦ is presented when the square root extraction mode is selected, the low flow cut point should be set. Cut point is adjustable within the range of 0.00 to 20.00%. The cut point is used for stabilizing output near 0% when the square root extraction mode is selected for output signal. There are two modes; in one mode, proportional output is selected for output below a cut point (Fig. A) and in the other mode, output is forcibly reduced to 0% for output below a cut point (Fig. B).

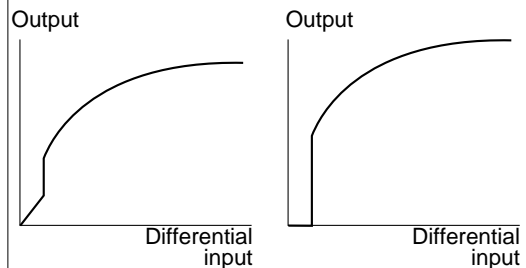
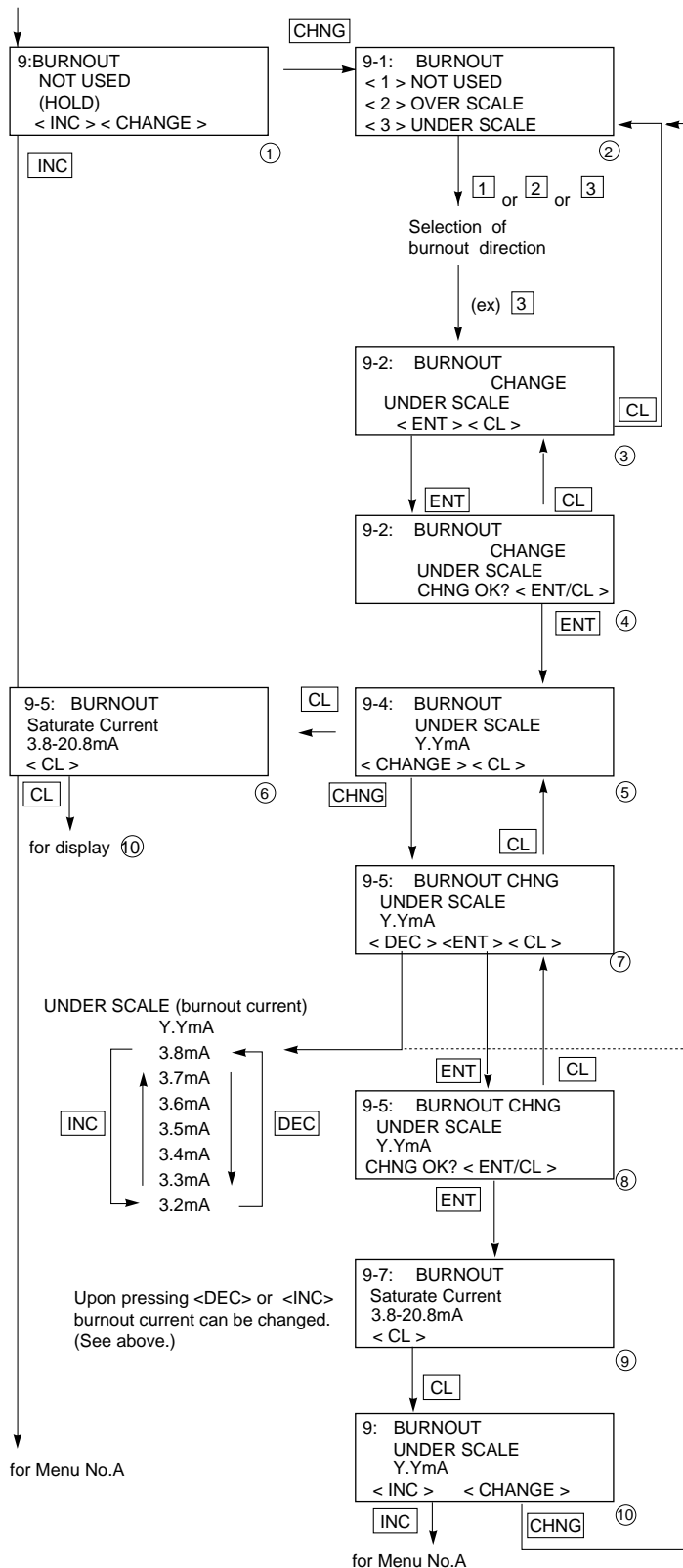

Fig. A: With linear output selected in low cut mode

Fig. B: With zero output selected in low cut mode

Under display ⑬, linear or zero output is selectable for output below the cut point.



Burnout direction

Used for selecting output at occurrence of a fault in the detecting unit. Burnout direction is selectable under display ②.

- For selection of NOT USED, press <1>.
- For selection of OVER SCALE, press <2>.
- For selection of UNDER SCALE, press <3>.

The meaning of each condition above is as follows.

- NOT USED → Not used (Output hold)
Saturation current=3.8, 20.8mA

Note) Output value just before the occurrence of trouble is given in the output hold mode.

- OVER SCALE → Over scale (Output 20.8 to 21.6mA)

Saturation current=3.8, 20.8mA

- UNDER SCALE → Under scale (Output 3.2 to 3.8 mA)

Saturation current=3.8, 20.8mA

Burnout Current of FCX-AII series transmitter

Over scale burnout current=20.8 to 21.6mA

Under scale burnout current=3.2 to 3.8mA

Saturation current=3.8, 20.8mA

Change of Over scale current

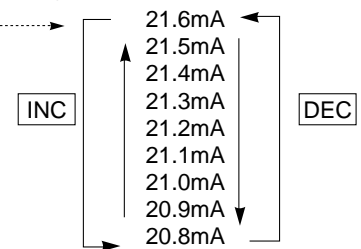

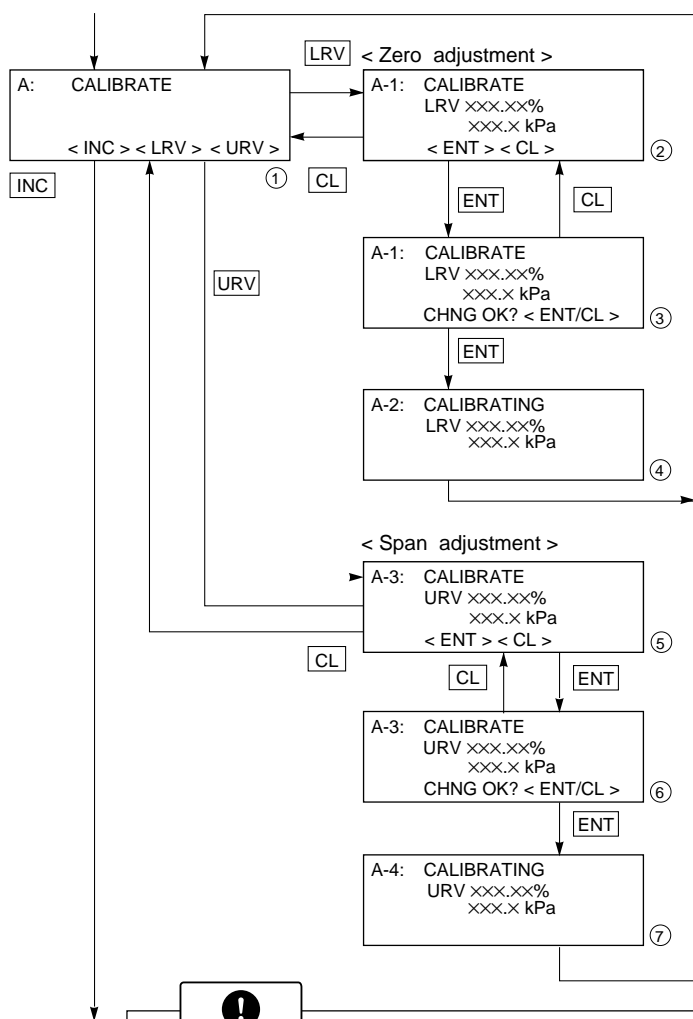

Zero/span adjustment

Zero and span are adjustable by applying an actual pressure.

When pressing <LRV> under display ①, the screen for zero adjustment ② appears, and that for span adjustment ⑤ appears when pressing <URV>.

Under display ②, after applying actual pressure equal to zero point, press <ENT> two times. Zero adjustment will be over.

When adjustment is made at any point other than zero, input the pressure value at that point at the display of ②, then press the <ENT> key at the display of ③ while applying a corresponding pressure to the transmitter.

Under display ⑤, after applying actual pressure equal to desired span, press <ENT> two times. Span adjustment will be over.

When adjustment is made at any point other than span, input the pressure value at that point at the display of ⑤, then press the <ENT> key at the display of ⑥ while applying a corresponding pressure to the transmitter.



Press LRV or URV at display of ①.

When the following is displayed, it means that calibration can not be made because Menu No. H: LINEARIZE is effective. In this case, set INVALID on the panel of No. H: LINEARIZE.

```
A-1:CALIBRATE
Can't proceed.
Set Linearize
invalid <CL>
```

- Span adjustment should be performed after zero adjustment is completed.
- When the actual input exceeds the adjustable range, [NOT CALB <CL>] is displayed. In this case, adjustment is required again.

Adjustable range

Zero adjustment: Within $\pm 40\%$ of maximum span

Span adjustment: Within $\pm 20\%$ of calibrated span

- When the adjustment point does not meet the following condition, [SETTING ERR<CL>] is displayed. In this case, adjustment is required again.

Adjustment point setting condition

$$-1.000\%CS^{(*)} \leq PL \leq 100.000\%CS^{(*)} \quad 0.000\%CS^{(*)} \leq PH \leq 110.000\%CS^{(*)}$$

$$PL = \frac{(\text{Lower adjustment point}) - LRV}{URV - LRV} \times 100$$

$$PH = \frac{(\text{Higher adjustment point}) - LRV}{URV - LRV} \times 100$$

(*) : CS (Calibrated Span) is equal to measuring range.

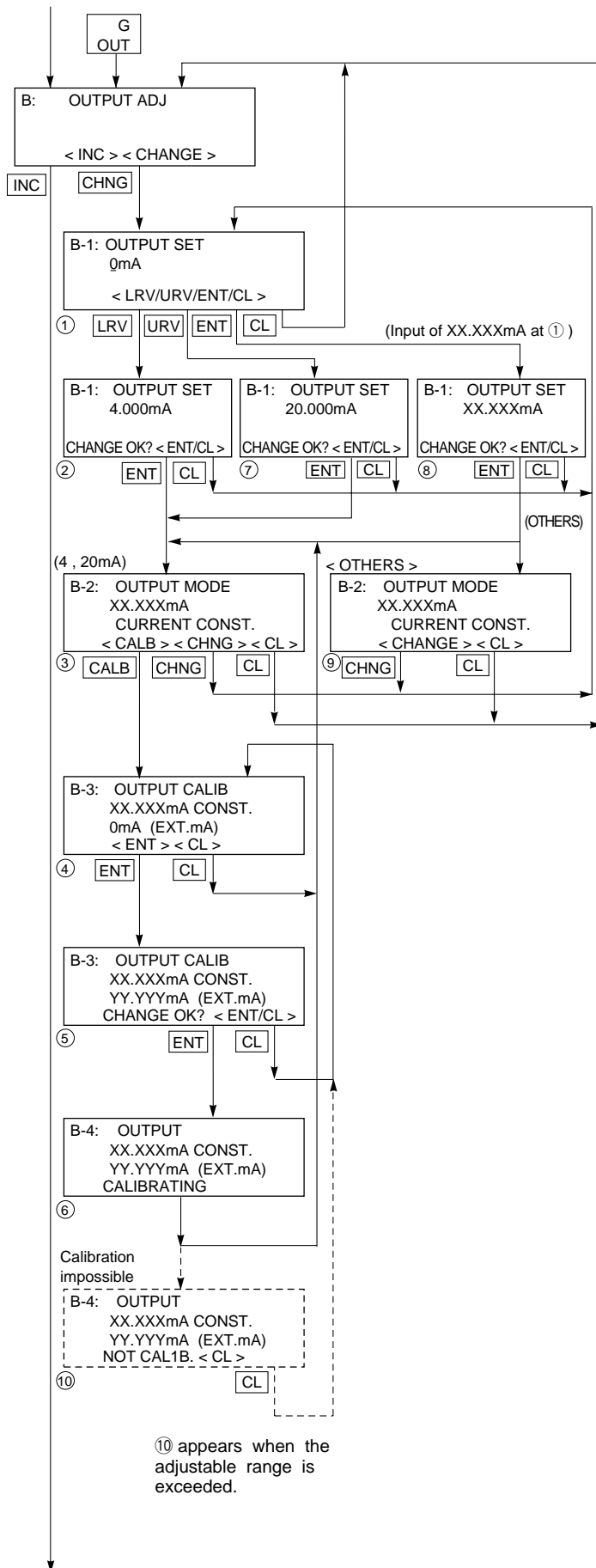

Calibration of output circuit (D/A)

The output circuit (D/A) should be calibrated by the following procedure when necessary.

Make calibration wiring transmitter according to “Calibration” in Appendix A2, and calibrate the output circuit with the HHC using the following procedure.

When the <LRV> key is pressed at the display of ①, the display ② for 4mA current output and its calibration will appear on the screen. When the <URV> key is pressed, the display ⑦ for 20mA current output and its calibration will appear on the screen.

Under display ①, input a desired value within a range of 3.8 to 20.8mA and then press <ENT> two times. At this input value, a regulated current output is available.

Under display ④, input digital values measured by digital voltmeter.

Under display ⑤, the output circuit is calibrated when pressing <ENT>.

Important

After setting and calibrating the constant current output, be sure to reset the HHC display to the initial display.

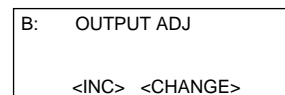

In this way, the transmitter output is reset to the measurement output. It should be noted that if HHC is removed from the transmitter loop or the HHC power is turned OFF when the constant current output has been set, the transmitter output is retained at the constant current output.

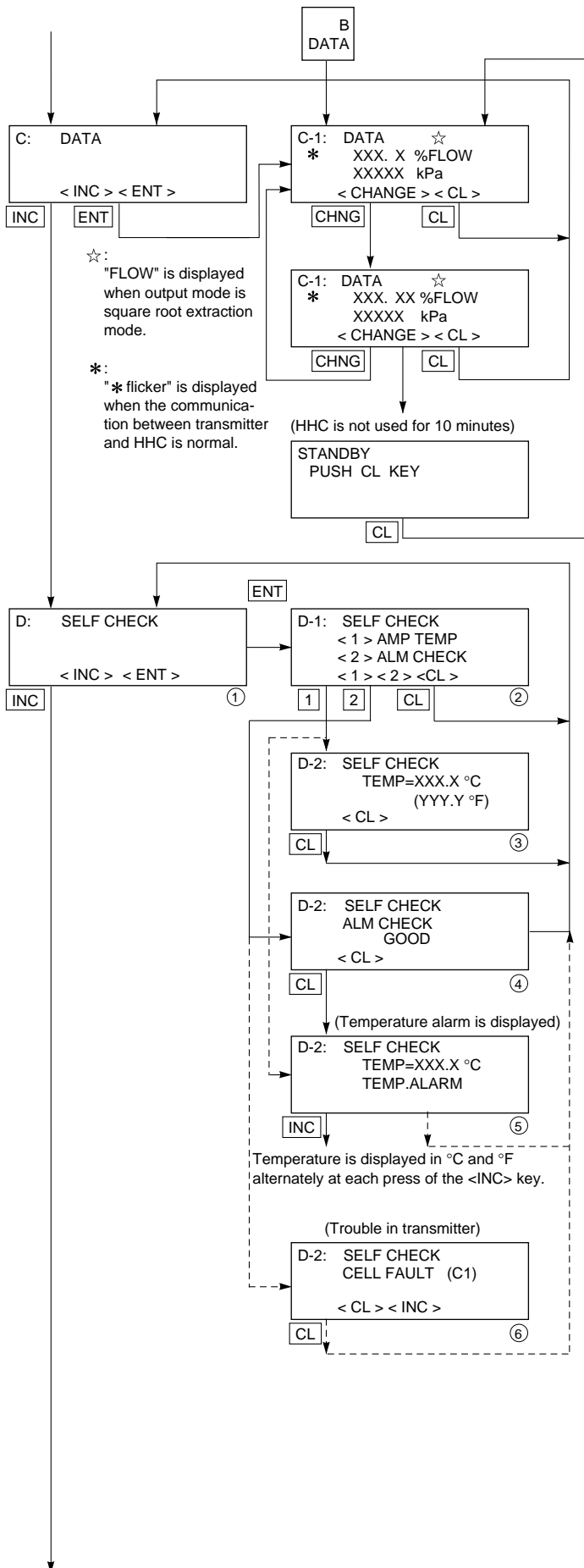

Indication of measured data

The measured value can be indicated. For more information about operating procedure, refer to the instruction manual of HHC.

Self-diagnosis

Use for displaying the measured temperature in the transmitter and the alarm information.

When pressing <1> on display ②, the temperature in the amplifier (AMP TEMP) is displayed. When pressing <2>, result of self-diagnosis about transmitter (ALM CHECK) is displayed.

Result of diagnosis

When the temperature in the amplifier is normal:

```
D-2: SELF CHECK
      TEMP= xxx.x°C
      <CL>
```

When temperature alarm is detected:

```
D-2: SELF CHECK
      TEMP= xxx.x°C
      TEMP. ALARM
      <CL>
```

When no error has occurred:

```
D-2: SELF CHECK
      ALM CHECK
      GOOD
      <CL>
```

When an error has occurred:

```
D-2: SELF CHECK
      CELL FAULT (C1)
      <CL> <INC>
```

For contents of error, refer to "Contents of message" on the next page.

[Contents of message]

As a result of self-diagnosis, the message below is appeared on the LCD display of HHC, when there are trouble in the transmitter. For each error, its cause and remedy are suggested.

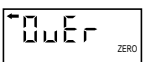
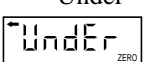
Message	Indication on digital indicator	Cause	Remedy
CELL FAULT (C1) } CELL FAULT (C9) ^(*1)	FL-1	Error of detecting unit	Replacement of detecting unit
EEPROM (AMP) FLT	FL-2	EEPROM error on amplifier side	Replacement of amplifier
EEPROM (CELL) FLT	FL-3	EEPROM error on cell side	Replacement of detecting unit
TEMP. ALARM	T.ALAM  ^(*2)	Transmitter temperature is not within the allowable range (-45 to 90°C).	Transmitter temperature is normalized.
XMTR FAULT	OVER  ^(*2)	Input pressure is 105% or higher of setting range.	Properly controlled.
	Under  ^(*2)	Input pressure is -1.25% or lower of setting range.	Properly controlled.

(*1) CELL FALUT (C5) to (C9) are appeared in case of “9” in 6th digit code of FKC.

(*2) Real indication

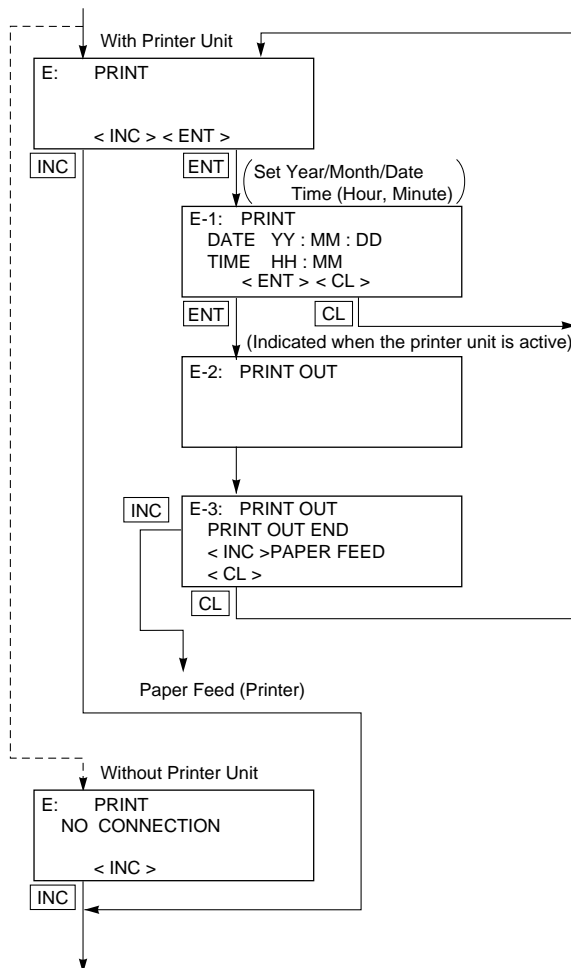

Printer function

Usable only when a printer is connected.
Refer to the instruction manual of HHC.

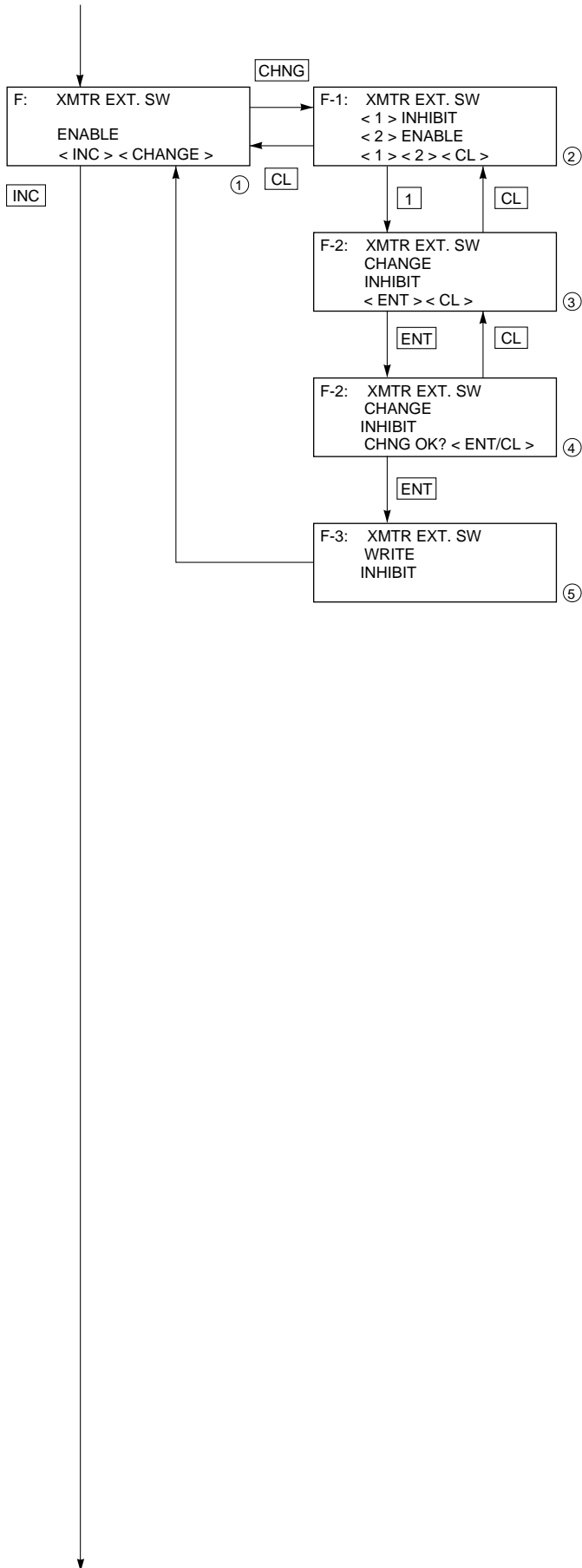

Lock of adjustment function

The zero adjustment function can be locked by the transmitter adjust screw.

When pressing <1> (INHIBIT) under display ②, the external switch lock function is activated, and it is released when pressing <2> (ENABLE).

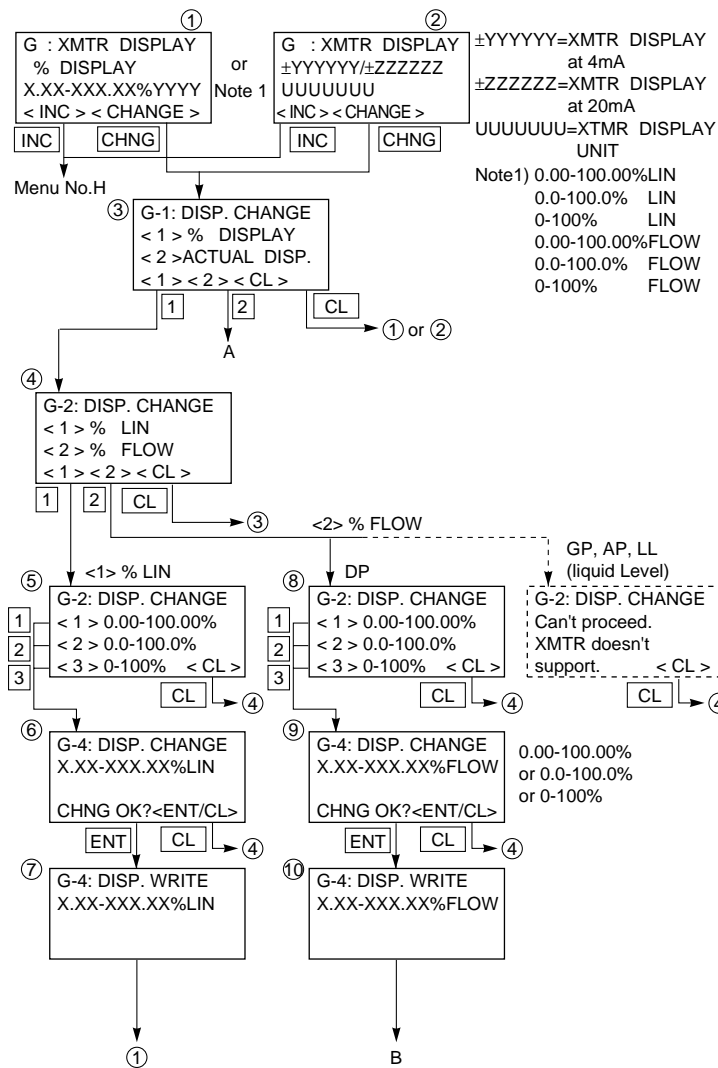

Indication of digital indicator

For digital indicator, either % display or actual-scale display is selectable. In display on the actual scale, display values corresponding to 0% (4mA) and 100% (20mA) are settable.

In setting % display, proportional mode and square root extraction mode is selectable as shown in ④.

In ④,

<1> %LIN is displayed in % in the proportional mode

<2> %FLOW is set by % in the square root extraction mode (proportional to flow)

In case of pressure transmitter and level transmitter, <2> % FLOW cannot be set in ④.

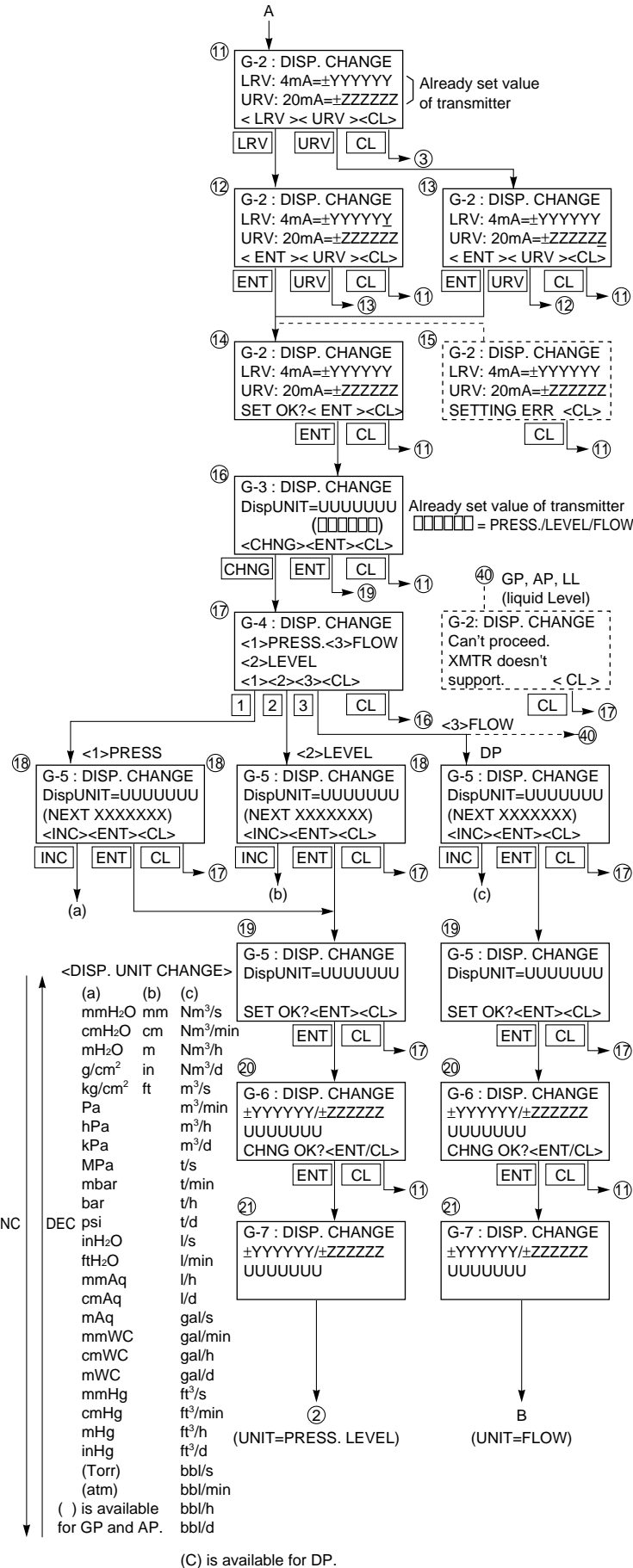

When setting the actual-scale display, first select <2> ACTUAL DISP in ③. Next, after setting the actual-scale display value (⑪ to ⑭), perform the actual-scale display unit setting (⑯ to ⑲). In case of pressure transmitter, absolute pressure transmitter and level transmitter, the flow units cannot be set as shown in ⑰. After making sure of the setting of the actual-scale display ⑳, enter the [ENT] and then data is written in the transmitter.

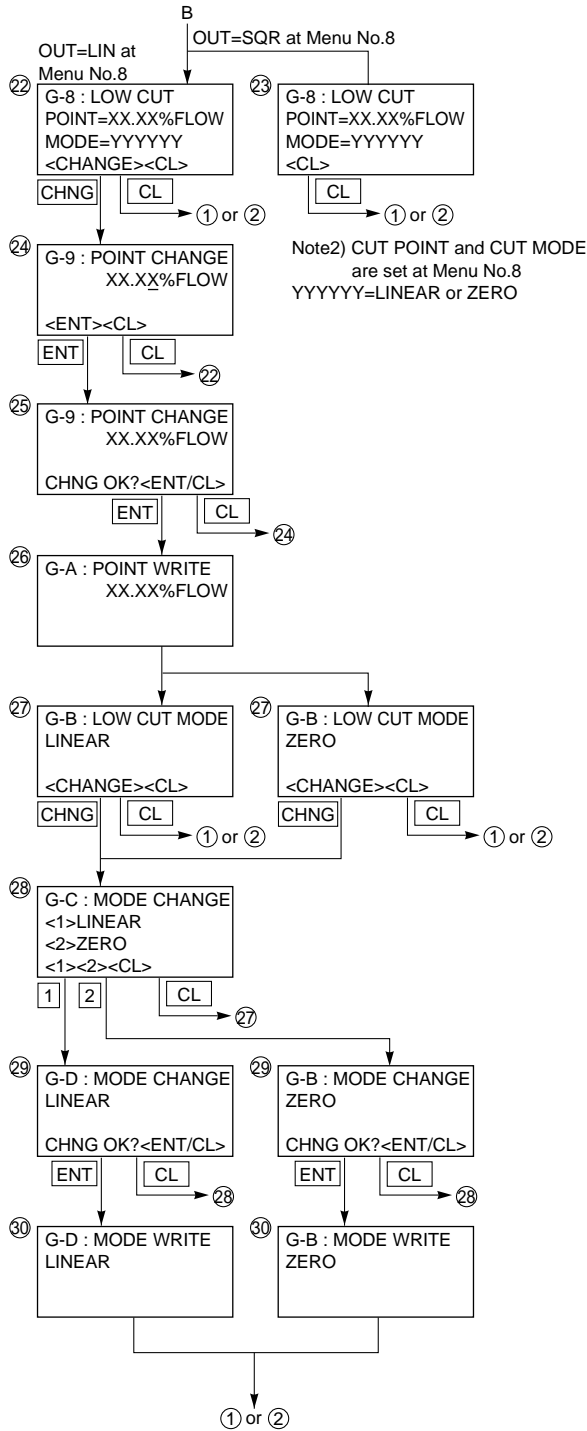

When setting of % Flow in %display or Flow unit in actual scale display, low flow cut point and low flow cut mode are displayed (② or ③).

When, in the OUTPUT MODE (Menu No. 8), OUT = SQR is set, already set low flow cut point and low flow cut mode are displayed (③).

With OUT = LIN set, the present low flow cut point and low flow cut mode are displayed (②). Then, enter <CHANGE>, and the setting can be renewed.

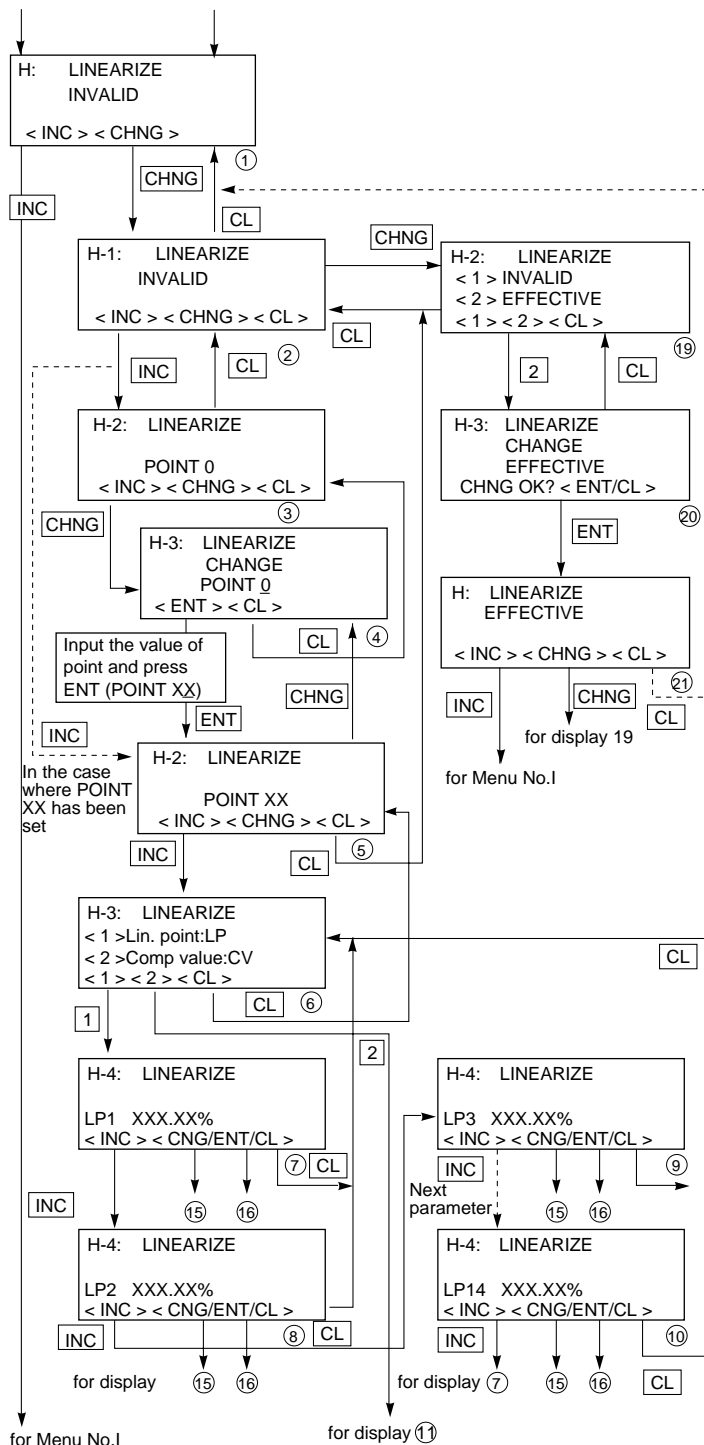

Programmable linearization function

User can set output compensation against the input using 14 compensation points, $(X_1, Y_1), (X_2, Y_2) \dots (X_{14}, Y_{14})$. Each compensation value between (X_n, Y_n) and (X_{n+1}, Y_{n+1}) is connected by first order approximate formula.

This linearization function is useful to compensate the tank figure in level measurement application and the flow rate of steam or gas in flow measurement application.

Functions for LINEARIZE are available for FXW Version 6.0 and upward.

By pressing INC at display of ②, the display is shifted to the setting of LINEARIZE POINT ③. Press CHNG at display of ③ and input POINT XX to be compensated. Then press ENT and the display will be shifted to ⑤.

Press INC at display of ⑤ and the display will be shifted to ⑥ for selection of <1> Lin. point: LP and <2> Comp. value: CV.

Select <1> Lin. point: LP at display of ⑥ and input XXX.XX% to each point (LP1-LP□).

At the completion of input to all the compensated points, press ENT twice and the write of LP will be finished.

At this time, the display is shifted to ⑥. Select <2> Comp. point: CV at display of ⑥ and input XXX.XX% to each point (CV1-CV□) in the same manner as noted in <1> LP.

At the completion of input to all the compensated points, press ENT twice and the write of CV will be finished.

At the completion of write of compensated program for LP/CV, press CL twice at the display of ⑥ for shifting to ②. Then, press CHNG for selection of <1> INVALID and <2> EFFECTIVE of ⑱. At display of ⑱, press <2> and the display will be changed to EFFECTIVE.

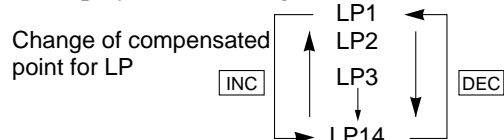

Note) In the key stroke for Linearization, please set each parameter in the below sequence.

1. Set the number of compensation points in the range of 2 to 14.
2. Set each linearization option point (LP*) correctly, and write them.
3. Set each compensation value (CV*) correctly, and write them.
4. Set linearization option into EFFECTIVE and write.

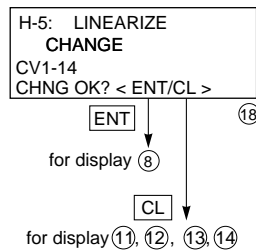
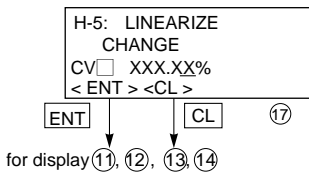
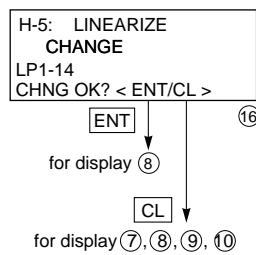
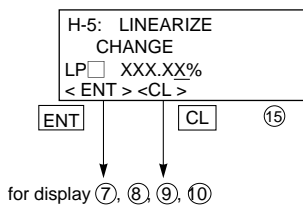
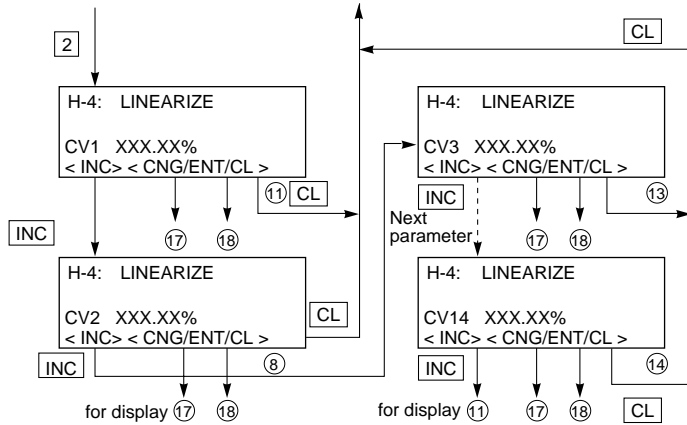

Important

When ENT is pressed at display of ⑳, the following is displayed,

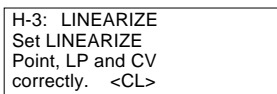

Requirement of setting

1. $LP \leq LP2 \leq LP3 \dots LP8 \leq LP9 \dots LP13 \leq LP14$ (In the case that LP1-LP14=All Zero, it is inhibited to be set enable)
2. If $CVa \neq CVb$, then it must be $LPa < LPb$. (Note 1)
3. If $LPa = LPb$, then it must be $CVa = CVb$. (Note 1)
Note 1) a, b show next numeral such as a=1 b=2 or a=2 b=3 ora=13 b=14.

or

the following is displayed.

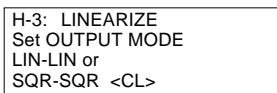

Change of compensated point for CV

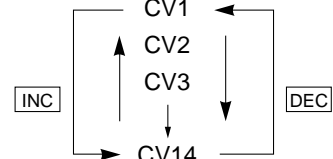

Important

When INC is pressed at display of ③, the following is displayed,

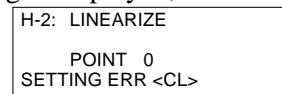

or

When ENT is pressed at display of ④, the following is displayed,

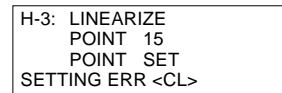

$POINT = 2 \leq (\text{number of correction}) \leq 14$
setting err=00 or 01 or ≥ 15

When ENT is pressed at display of ⑮, the following is displayed,

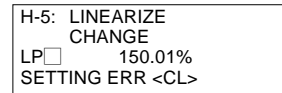

Requirement of setting

$-1.25\% \leq LP1 < LP2 \dots < LP14 \leq +110\%$

When ENT is pressed at display of ⑰, the following is displayed,

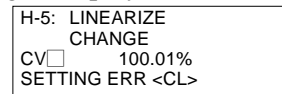

Requirement of setting

$-100\% \leq CV1 < CV2 \dots < CV14 \leq +100\%$

Before performing the LINEARIZE setting, set either of the following equations in the OUTPUT mode (Menu No. 8) and XMTR DISPLAY (Menu No. G):
OUT = LIN SMTR DISP = LIN or
OUT = SQR XMTR DISP = FLOW (Note 1)

Note 1) XMTR DISP = FLOW means the settings of % FLOW in %display or of FLOW units in actual-scale display.

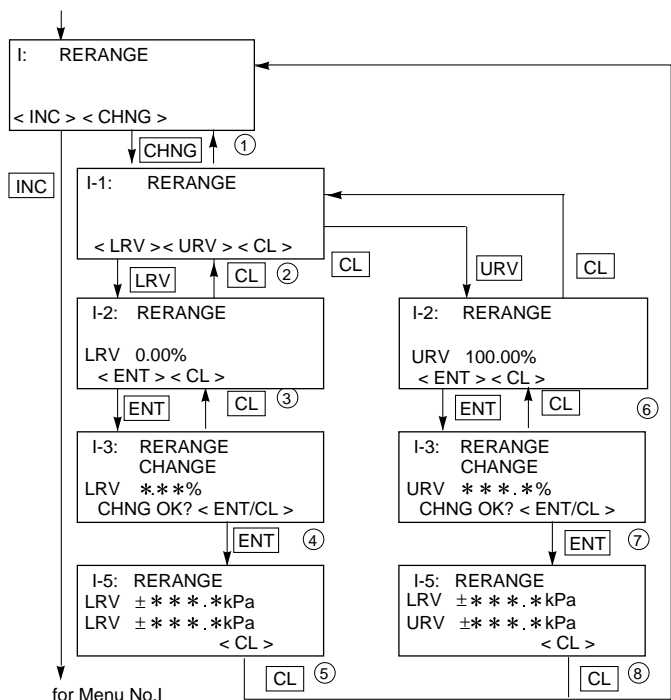

Rerange (Set LRV/URV calibration)

(application to level measurement) at change of level (LRV/URV)

Functions of RERANGE can be made with FXW Version 6.0 or upward.

When the lower range value (LRV) and upper range value (URV) need to be adjusted again during measurement of tank level, the measurement levels can be changed at the same time by setting the LRV or URV to be adjusted from FXW.

Apply an input pressure required for rerange of LRV at display of ③ and press ENT twice.

In this way, the rerange of LRV is completed, then the new measurement range LRV and URV, which conforms to the actual input pressure, is displayed.

When rerange is made at a point other than 0%, input the set value (PV%) of that point at display of ③, and press ENT at display of ④ while applying a corresponding pressure. In this way, the measurement range can be changed to the input corresponding to that pressure.

Apply an input pressure required for rerange of URV at display of ⑥ and press ENT twice. The rerange of URV is completed, then the new measurement range LRV and URV corresponding to the actual input pressure is displayed. When rerange is made at a point other than 100%, input the set value (PV%) of that point at display of ⑥ and press ENT at display of ⑦ while applying a corresponding pressure. In this way, the measurement range can be changed to the input corresponding to that pressure.

Note) The unit of LRV/URV at ⑤ and ⑧ are displayed in the unit selected by Menu No. 4:UNIT.



Important

Adjustment point setting condition

$$-1.00\% \leq \text{LRV} \leq 100.00\% \quad 0.00\% \leq \text{URV} \leq 110.00\%$$

In the case that point is out of setting limit.

(Ex)

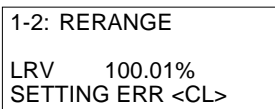

In case of the actual scale specification with a digital indicator provided, if the range is changed, indicator display might not match. So, setting is required again in response to the display in the digital indicator (G:XMTR DISPLAY).

In case of the actual scale specification with an analog indicator provided, if the range is changed, the scale for indicator might not ensure exact reading.

When CHNG is pressed at display of ①, the following is displayed.

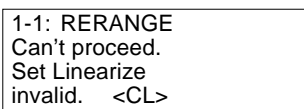

This means that RERANGE cannot be made because MENU No. H: LINEARIZE is set in EFFECTIVE. In this case, press the CL key and set in INVALID on the panel of No. H: LINEARIZE.

A1.2 Adjustment by the screw

Zero point is adjustable by screw at the transmitter body. (Span is to be adjusted with the HHC.)

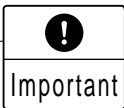
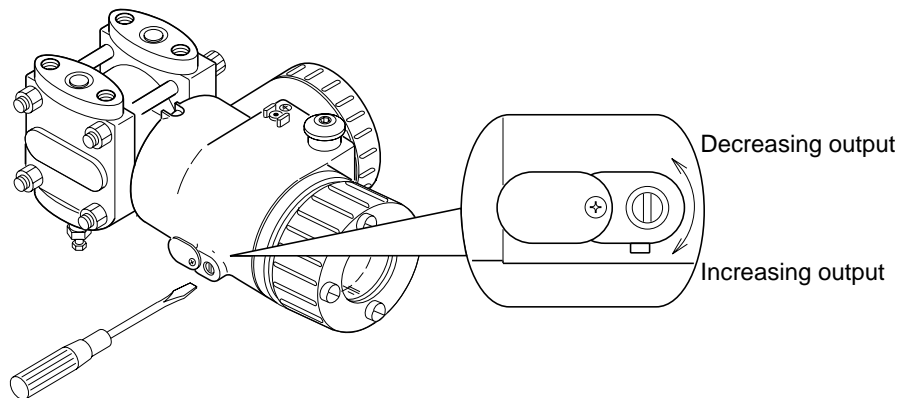

1. After adjustment, the transmitter should be kept energized at about 10 seconds to write the adjustment results into memory.
2. When the external switch lock function is activated, adjustment by the screw at the transmitter is impossible.

A2. CALIBRATION

Calibration procedure

(1) Make wiring according to the diagram below.

Connect DC power supply (power source), digital voltmeter (measuring device), standard resistance and HHC (Hand Held Communicator):

When current is measured with an ammeter connected to CK+ and CK- terminals, the internal resistance of the ammeter should be 12Ω or less.

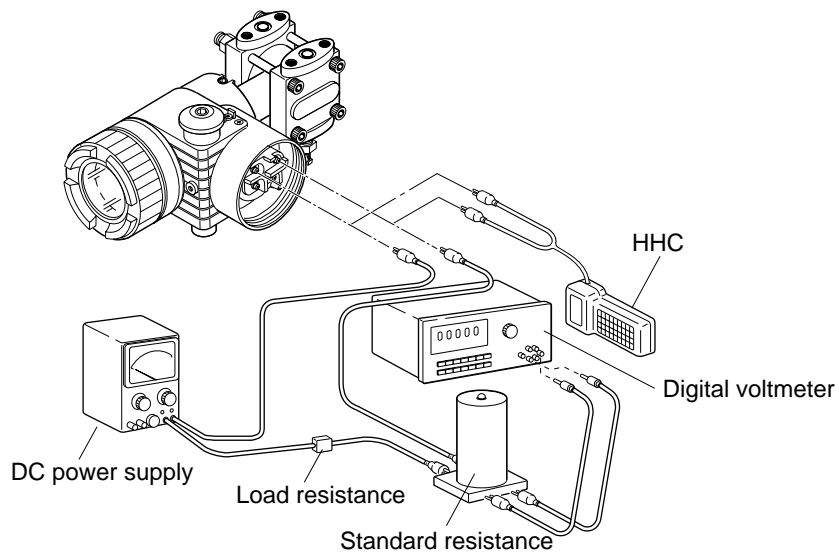

Important

For communication with the HHC, a load resistor of 250Ω is necessary.

(2) Calibration of output circuit (D/A)

Calibrate the output circuit with reference to “Calibration of output circuit” in “ADJUSTMENT” in Section A1.

(3) Zero/span adjustment

Refer to “Zero/span adjustment” in Section A1.

(4) Accuracy test

Apply input pressures in the order of 0%, 25%, 50%, 75%, 100%, 75%, 50%, 25% and 0%, and read output at each input pressure.

Make sure the difference between each output value and input pressure (%) is within the accuracy rating listed in the table below.

The voltage values in the table are dependent on use of “DC power supply + standard resistor 250Ω + digital voltmeter (measuring device).

Measurement category	Reference value	Accuracy	
		Accuracy:0.1%	Accuracy:0.2%
Percent display (%)	0, 25, 50, 75, 100	±0.1	±0.2
Current measurement (mA)	4, 8, 12, 16, 20	±0.016	±0.032
Voltage measurement (V)	1, 2, 3, 4, 5	±0.004	±0.008

A3. BUILT-IN ARRESTER

General

An arrester is used to protect a transmitter or receiver from an abnormal voltage such as lightning surges induced into signal lines. A built-in type arrester is mounted behind the terminal unit. A nameplate marked "with arrester" is attached to the terminal unit of transmitter with a built-in arrester.

Installation

The built-in arrester should be used in combination with panel mounting type arrester (type PXC) for distributor protection.

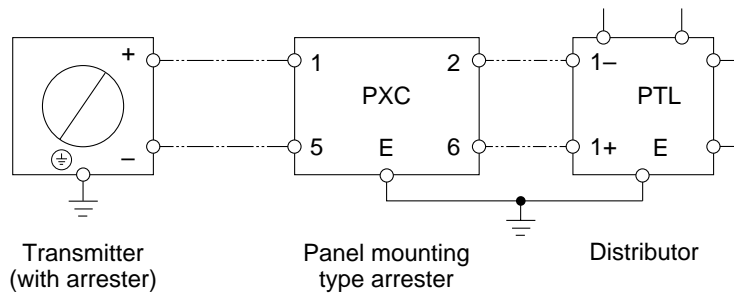

Grounding

Since transmitter and arrester groundings are internally connected together, user have only to connect the external grounding terminals to ground.

Grounding terminal must be used, in case of the explosionproof or intrinsic safety type transmitter.

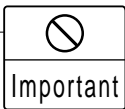
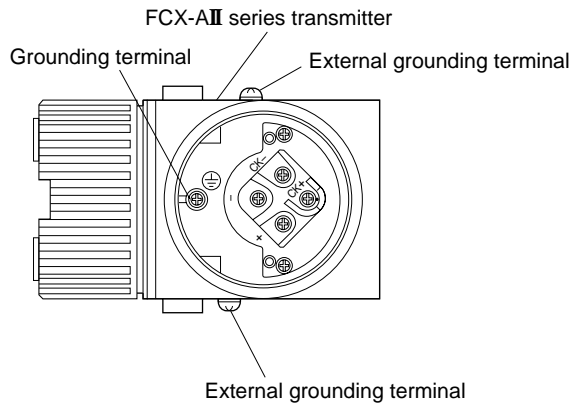

1. Grounding resistance should be 100Ω or less.
2. Avoid common grounding with a lightning rod.

Maintenance

Check of arrester

- Measure output current from the transmitter check terminals and output current to flow into transmitter (see figure below).
When current is measured with an ammeter connected to CK+ and CK- terminals, the internal resistance of the ammeter should be 12Ω or less.
- If the measured two output current are the same, the arrester is normal.
- In case the measured values have a difference of 0.1% (0.016mA) or more, the arrester is not functioning.
- In the above case, the arrester unit (terminal unit) should be replaced with a new one.

Limitation of insulation resistance and dielectric strength test

An insulation resistance and dielectric strength test should be avoided as a rule, since it may damage the arrester.

Output measurement at check terminals

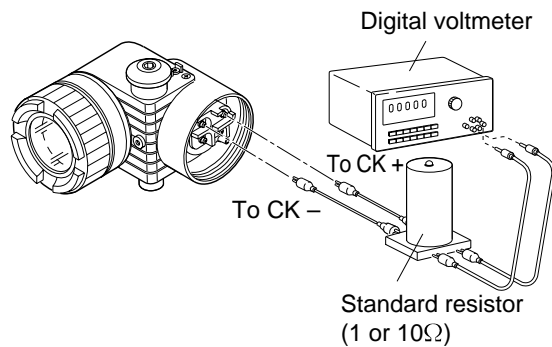

Output measurement outside transmitter

* Disconnect the wire from the - (minus) terminal and connect the measurement device as shown below.

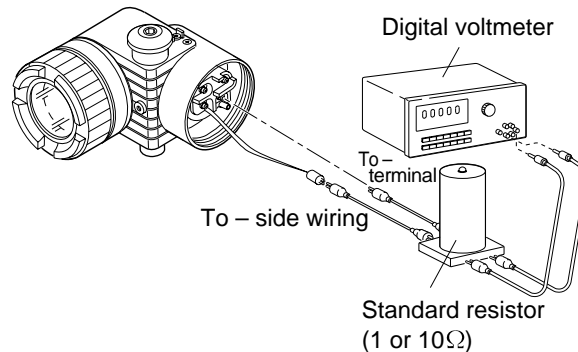

Fuji Electric Systems Co., Ltd.

Head Office

Gate City Ohsaki, East Tower, 11-2, Osaki 1-chome,
Shinagawa-ku, Tokyo 141-0032, Japan
<http://www.fesys.co.jp/eng>

Instrumentation Div.

International Sales Dept.

No.1, Fuji-machi, Hino-city, Tokyo 191-8502, Japan
Phone: 81-42-585-6201, 6202 Fax: 81-42-585-6187
<http://www.fic-net.jp/eng>
