



Instruction Manual

**PORTABLE INFRARED
GAS ANALYZER**

TYPE: ZFY

PREFACE

Congratulations on your purchase of Fuji Electric's Portable Infrared Gas Analyzer (Type: ZFY).

- Before using, be sure to read this instruction manual carefully to ensure correct installation, operation and maintenance of the infrared gas analyzer. Note that incorrect handling may lead to trouble or personal injury.
- The specifications of this infrared gas analyzer are subject to change for improvement without prior notice.
- Do not attempt to modify the infrared gas analyzer without permission. Fuji is not responsible for any trouble caused by modification without permission.
- This instruction manual should always be kept on hand by the user.
- After reading, be sure to keep this manual in a place where it can easily be seen by the operator.
- Make sure that this manual is presented to the final user.

Manufacturer : Fuji Electric Instrumentation Co., Ltd.
Type : Described in Fuji Electric's company nameplate on main frame
Date of manufacture : Described in Fuji Electric's company nameplate on main frame
Product nationality : Japan

Delivered items

- Main unit 1
- Power cord 1
- Power fuse (tube type; 1A, $\phi 6.4 \times 30$)..... 1
- Instruction manual 1
- Filter paper 25
- Calibration gas piping connecting joint 1
- Main unit vinyl cover 1
- $\phi 9/5$ elastic tube, 5cm (for $\phi 6$ tube connection)..... 1
- Hose band ($\phi 10$) 2

NOTICE

- It is prohibited to transfer part or all of this manual without Fuji Electric's permission in written format.
- Description in this manual will be changed without prior notice for further improvement.



© Fuji Electric Systems Co., Ltd. 1998



Issued in July, 1998

SAFETY PRECAUTION

First of all, read this “Safety Precaution” carefully, and then use the analyzer in the correct way.

- The cautionary descriptions listed here contain important information about safety, so they should always be observed. Those safety precautions are ranked 2 levels; “DANGER” and “CAUTION”.

Warning & Symbol	Meaning
 DANGER	Wrong handling may cause a dangerous situation, in which there is a risk of death or heavy injury.
 CAUTION	Wrong handling may invite a dangerous situation, in which there is a possibility of medium-level trouble or slight injury or only physical damage is predictable. .

Caution on installation and transport of gas analyzer	
 DANGER	This unit is not an explosion-proof type. Do not use it in a place with explosive gases to prevent explosion, fire or other serious accidents.
 CAUTION	<ul style="list-style-type: none">• For installation, observe the rule on it given in the instruction manual and select a place where the weight of gas analyzer can be endured. Installation at an unsuited place may cause turnover or fall and there is a risk of injury.• For lifting the gas analyzer, be sure to wear protective gloves. Bare hands may invite an injury. .• Before transport, fix the casing so that it will not open. Otherwise, the casing may be separated and fall to cause an injury.• During installation work, care should be taken to keep the unit free from entry of cable chips or other foreign objects. Otherwise, it may cause fire, trouble or malfunction of the unit.

Caution on piping



DANGER

In piping, the following precautions should be observed. Wrong piping may cause gas leakage.

If the leaking gas contains a toxic component, there is a risk of serious accident being induced.

Also, if combustible gas is contained, there is a danger of explosion, fire or the like occurring.

- Connect pipes correctly referring to the instruction manual.
- Exhaust should be led outdoors so that it will not remain in the locker and installation room.
- Exhaust from the analyzer should be relieved in the atmospheric air in order that an unnecessary pressure will not be applied to the analyzer. Otherwise, any pipe in the analyzer may be disconnected to cause gas leakage.
- For piping, use a pipe to which oil and grease are not adhering. If such a material is adhering, a fire or the like accident may be caused.

Caution on wiring



CAUTION

• Wiring is allowed only when all power supplies are turned off. This is required for preventing a shock hazard.

• Enforce construction of class-3 grounding wire by all means. If the specified grounding construction is neglected, a shock hazard or fault may be caused.

• Wires should be the proper one meeting the ratings of this instrument. If using a wire which cannot endure the ratings, a fire may occur.

• Use power source that matches the rating of the unit. Use of power source out of rating may cause fire.

Caution on use



DANGER

• When handling the standard gas such as calibration gas, read the instruction manual of the standard gas carefully and use the gas correctly.



CAUTION

• Avoid continuous operation with the casing drawn out.

• During operation, avoid opening the casing and touching the internal parts. Otherwise, you may suffer a burn or shock hazard.

Caution on maintenance and check



DANGER

- When doors are open during maintenance or inspection for adjusting the optical system, etc., be sure to purge sufficiently the inside of the gas analyzer as well as the measuring gas line with nitrogen or air, in order to prevent poisoning, fire or explosion due to gas leaks.



CAUTION

- Before working, take off a wrist watch, finger ring or the like metallic accessories. And never touch the instrument with a wet hand, Otherwise, you will have a shock hazard.
- If the fuse is blown, eliminate the cause, and then replace it with the one of the same capacity and type as before. Otherwise, shock hazard or fault may be caused.
- Do not use a replacement part other than specified by the instrument maker. Otherwise, adequate performance will not be provided. Besides, an accident or fault may be caused.
- Replacement parts such as a maintenance part should be disposed of as incombustibles.

Others



CAUTION

- If the cause of any fault cannot be determined despite reference to the instruction manual, be sure to contact your dealer or Fuji Electric's technician in charge of adjustment. If the instrument is disassembled carelessly, you may have a shock hazard or injury.

CAUTION ON USE

- **Select a suitable installation place.**

Install the unit in a place with normal temperature and humidity, free from excessive change in temperature and from heat radiation and direct sunlight.

This unit is designed for indoor installation. When it is installed outdoors, choose a place where it is not exposed to wind and rain. Be sure to use a proper case cover.

- **Do not install the unit in a place with vibrations.**

- **Cleaning of instrument**

Do not use solvents such as benzine, thinner, etc., as it damages the case.

- **Prohibition of use of transceivers and portable telephones:**

Do not use transceivers and portable telephones near the analyzer to prevent in correct measurement due to noise.

- **Use the unit in a place with good environment.**

The unit should be used in a place free from corrosive or combustible gases.

- **Be careful with electric shocks.**

The unit should be earthed to avoid electric shocks.

- **Key operation**

Do not use any object with a sharp tip when operating the function keys on the instrument panel.

CONTENTS

PREFACE	i
SAFETY PRECAUTION	ii
CAUTION ON USE	v
1. OUTLINE	1
2. NAME AND DESCRIPTION OF EACH COMPONENT	1
2.1 Name and description of each component on case	1
2.2 Name and description of component/operation panel	2
3. PREPARATION FOR MEASUREMENT	3
3.1 Installation	3
3.2 Piping	4
3.3 Wiring	6
4. OPERATION	7
4.1 Operation procedure	7
4.2 Start of measurement	7
4.3 Stop	7
5. OPERATION OF DISPLAY/OPERATION PANEL	8
5.1 Outline of display/operation panel	8
5.2 General operation	9
5.2.1 Calibration concentration setting	10
5.2.2 Key lock ON/OFF setting	10
5.2.3 Zero calibration	10
5.2.4 Span calibration	11
6. INSPECTION AND MAINTENANCE	12
6.1 Routine inspection and maintenance	12
6.2 Cleaning of measuring cell	13
6.2.1 Disassembly/reassemble of measuring cell	14
6.2.2 Cell cleaning procedure	15
7. ERROR CODE AND REMEDY	16
8. SPECIFICATIONS AND PERFORMANCE	17

1. OUTLINE

This portable infrared gas analyzer is equipped with a high performance sensor specifically developed for infrared gas analyzers. It is designed for many applications such as for measuring carbon dioxide gas in a green house for agriculture, and ordinary rooms, setting the inside of thermal processing furnace, etc.

2. NAME AND DESCRIPTION OF EACH COMPONENT

2.1 Name and description of each component on case

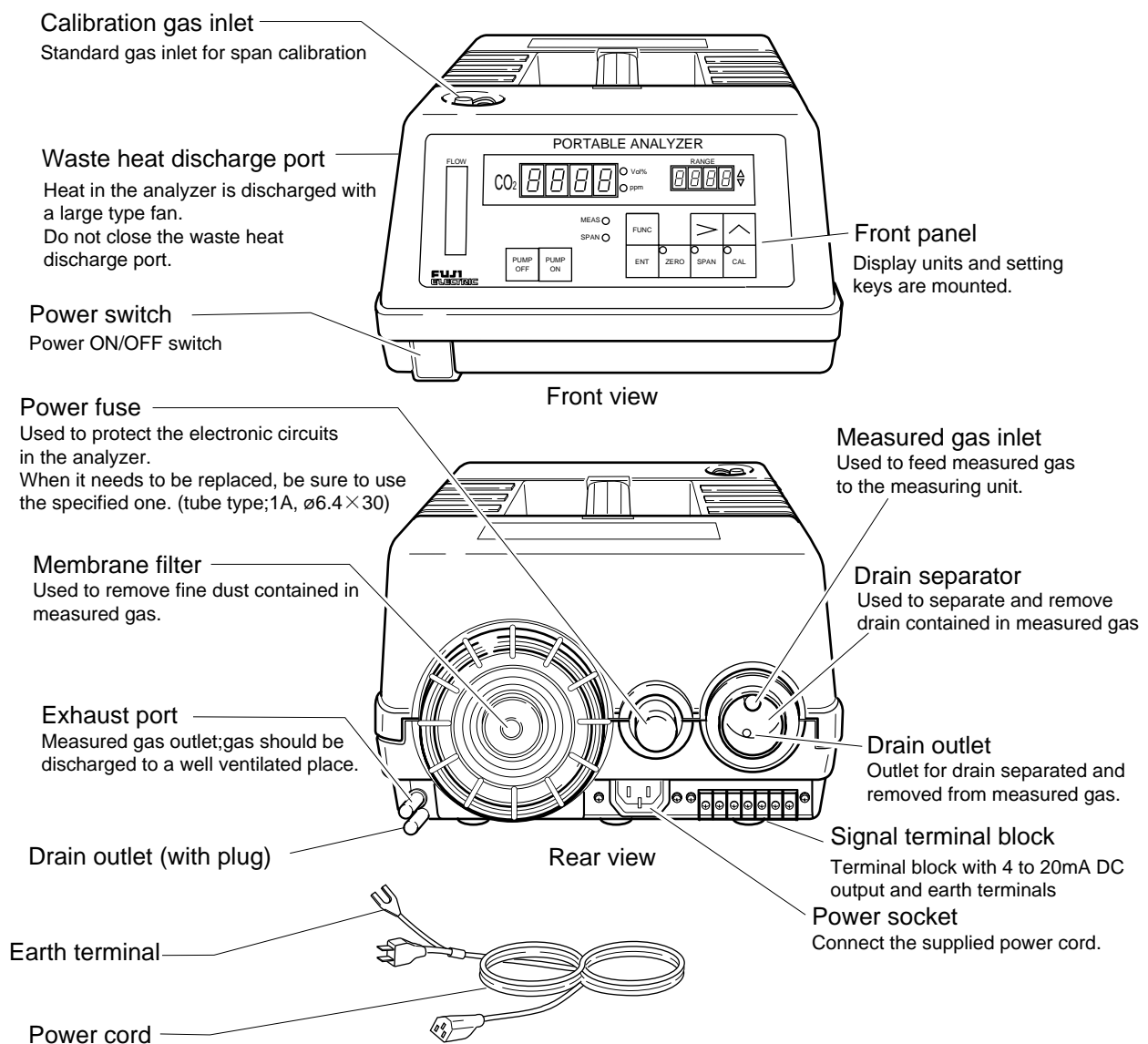

2.2 Name and description of component/operation panel

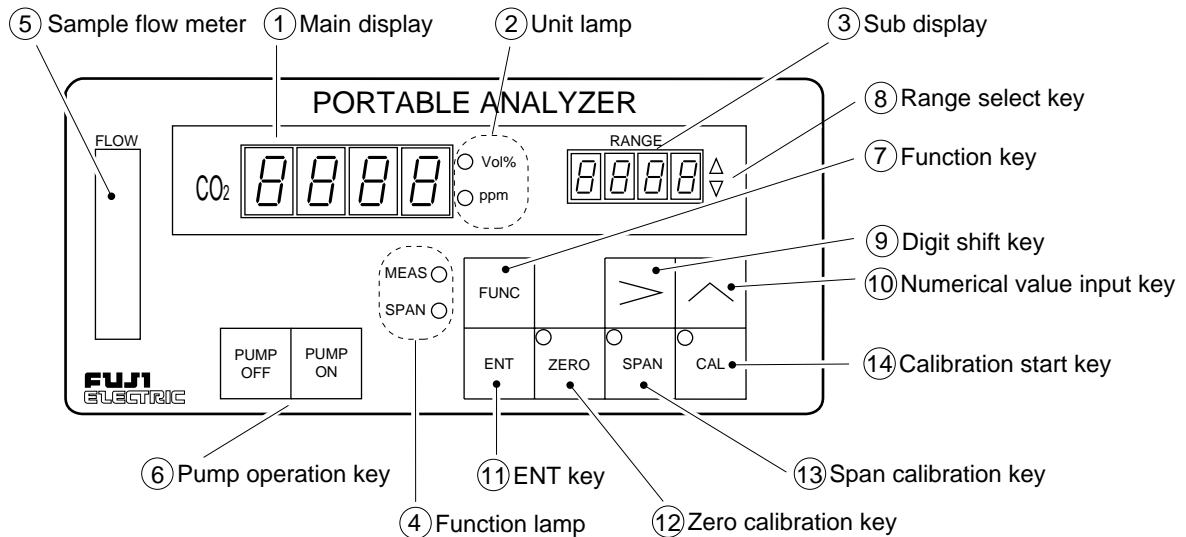

Name	Description
① Main display	Indicates gas density measured value or calibration gas set value.
② Unit lamp	Indicates the unit of measured gas concentration.
③ Sub display	Indicates measurement range, error code and various set values.
④ Function lamp	Lights up at the following function. MEAS: Lights in measuring status. SPAN: Flickers in calibration concentration setting mode.
⑤ Sample flow meter	Indicates sample flow rate.
⑥ Pump operation key	Used for pump ON-OFF
⑦ Function key	Desired setting mode is selected at a press of key (see Chapter 5).
⑧ Range select key	Used for selection of range. High range is selected by pressing \triangle key, and low range is selected by pressing ∇ key.
⑨ Digit shift key	Digit is shifted from maximum value to minimum one at a press of key.
⑩ Numerical value input key	Numerical value of selected digit increases at a press of key.
⑪ ENT key	By pressing this key after setting, the set data is stored in memory and become valid.
⑫ Zero calibration key	Used for zero calibration (lamp flickers in zero calibration mode).
⑬ Span calibration key	Used for span calibration (lamp flickers in span calibration mode).
⑭ Calibration start key	Manual calibration start key: Zero calibration is started by pressing ZERO \Rightarrow CAL keys. Span calibration is started by pressing SPAN \Rightarrow CAL keys. (CAL lamp lights during calibration)

3. PREPARATION FOR MEASUREMENT



DANGER

- This unit is not an explosion-proof type. Do not use it in a place with explosive gases to prevent explosion, fire or other serious accidents.



CAUTIONS

- For installation, observe the rule on it given in the instruction manual and select a place where the weight of gas analyzer can be endured.
Installation at an unsuited place may cause turnover or fall and there is a risk of injury.
- For lifting the gas analyzer, be sure to wear protective gloves. Bare hands may invite an injury.
- Before transport, fix the casing so that it will not open. Otherwise, the casing may be separated and fall to cause an injury.
- During installation work, care should be taken to keep the unit free from entry of cable chips or other foreign objects. Otherwise, it may cause fire, trouble or malfunction of the unit.

3.1 Installation

(1) Installation location

The unit should be installed on a level top of table near furnace.

(2) Caution on selection of installation location

- 1) A place with sufficient air ventilation and without furnace combustion waste gas
- 2) A place not exposed to heat radiation from furnace
- 3) A place with less changes in ambient temperature
- 4) A place away from electric device which generates noise from power source
- 5) A place where transceivers or portable telephones are not used.

3.2 Piping



DANGER

In piping, the following precautions should be observed. Wrong piping may cause gas leakage.

If the leaking gas contains a toxic component, there is a risk of serious accident being induced.

Also, if combustible gas is contained, there is a danger of explosion, fire or the like occurring.

- Connect pipes correctly referring to the instruction manual.
- Exhaust should be led outdoors so that it will not remain in the locker and installation room.
- Exhaust from the analyzer should be relieved in the atmospheric air in order that an unnecessary pressure will not be applied to the analyzer. Otherwise, any pipe in the analyzer may be disconnected to cause gas leakage.
- For piping, use a pipe to which oil and grease are not adhering. If such a material is adhering, a fire or the like accident may be caused.

(1) Piping procedure

① Sample inlet

Insert a Teflon tube ($\phi 6/\phi 4$) or copper pipe into the elastic tube ($\phi 9/\phi 5$) at the drain separator cap (gas inlet), and secure it with a hose band. Then, fix the drain separator cap to the drain separator at the rear right side.

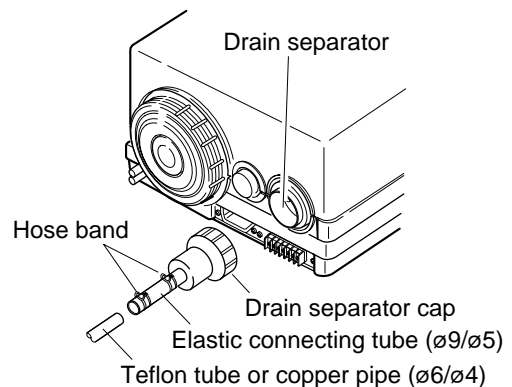

② Sample outlet

Connect Teflon tube ($\phi 6/\phi 4$) or copper pipe to the exhaust port tube ($\phi 9/\phi 5$ elastic tube) at the lower left on the rear side. Waste sample gas should be discharged to a non-hazardous place.

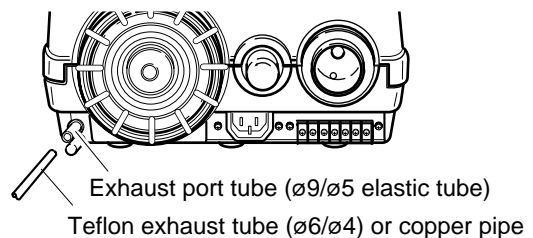



CAUTIONS

- Make sure that the drain outlet under the exhaust port is always closed. If an exhaust pipe is connected by mistake, the drain is mixed with the sample gas which may lead to a risk of combustion or explosion.
- The drain separator packing has front and rear sides. Be careful with its mounting position.

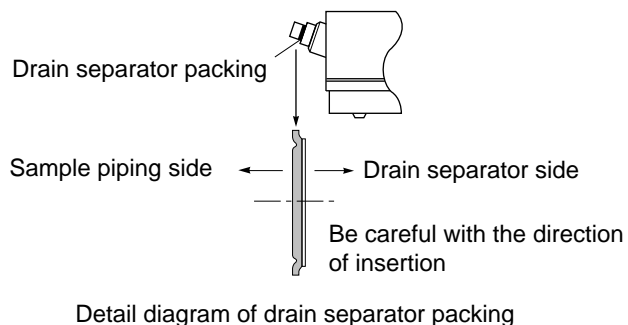
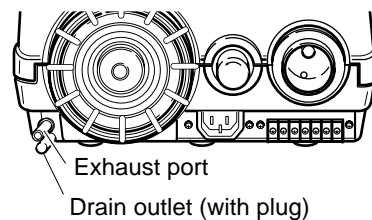

(2) Caution on sampling

- ① The analyzer has a filter paper. For continuous measurement, a filter should be used separately in the middle of the sampling tube (Fuji Electric's recommended filter: Mist filter, Type: ZBBK1V03).
- ② To prevent entry of high-temperature sample gas into the analyzer, make sure that the piping length is more than 2m.
- ③ The analyzer is not equipped with a dehumidifier. When sample gas dew point is higher than the ambient temperature, stop absorbing the sample gas.

3.3 Wiring



CAUTIONS

- Wiring is allowed only when all power supplies are turned off. This is required for preventing a shock hazard.
- Enforce construction of class-3 grounding wire by all means. If the specified grounding construction is neglected, a shock hazard or fault may be caused.
- Wires should be the proper one meeting the ratings of this instrument. If using a wire which cannot endure the ratings, a fire may occur.
- Use power source that matches the rating of the unit. Use of power source out of rating may cause fire.

(1) Power source

Connect the supplied power cable to the power socket at the rear panel.

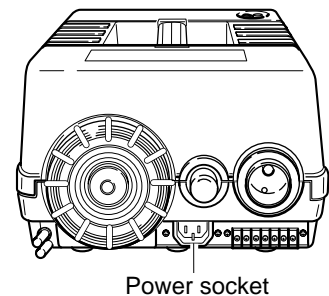

(2) Grounding

Connect the earth wire of the power cord to the signal connection terminal No. 3 (E) for Class-3 grounding.

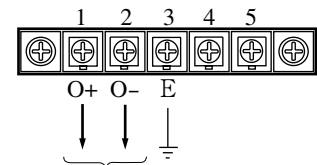

(3) Output signal

Gas concentration output 4 to 20mA DC is transmitted from the signal connection terminal No. 1 (O+) and No. 2 (O-).

To minimize the effect of external noise, be sure to use a shield wire.

Note) If noise from an external relay, solenoid valve, etc. affects the analyzer, connect a varistor (Fuji Electric: ENA211-2, etc.) or spark killer (OKAYA: S-1201, etc.) to the source of noise.

When it is connected at a place away from the source of noise, expected effects cannot be obtained.

4. OPERATION



DANGER

- When handling the standard gas such as calibration gas, read the instruction manual of the standard gas carefully and use the gas correctly.



CAUTIONS

- Avoid continuous operation with the casing drawn out.
- During operation, avoid opening the casing and touching the internal parts. Otherwise, you may suffer a burn or shock hazard.

4.1 Operation procedure

- ① Turn ON the power (power switch at the lower left of front panel should be set to ON)
Make sure that the pump is OFF. If the pump is ON, be sure to turn it OFF.
- ② Warming-up operation (about 30 minutes)
- ③ Calibration (zero/span calibration with sample gas) (see Chapter 5)

4.2 Start of measurement

Turn ON the pump using the pump operation key. The sample gas is absorbed and measurement is started.

4.3 Stop

- ① Turn OFF the pump using the pump operation key.
- ② Remove the sample piping to suck up the air, then turn ON the pump using the pump operation key and take up the air into the analyzer (5 minutes).
- ③ Turn OFF the pump again using the pump operation key and keep the analyzer in storage.

5. OPERATION OF DISPLAY/OPERATION PANEL

5.1 Outline of display/operation panel

Operation is made in the following order.

Key	Function	Main display	Sub display	Function indicating lamp	Page
→ <input type="button" value="FUNC"/>	Measurement mode	Measured value	Range	MEAS lamp light	9
↓ <input type="button" value="FUNC"/>	Setting mode	Calibration concentration	Range	SPAN lamp flicker	10
↓ <input type="button" value="FUNC"/>	Calibration concentration setting				
↓ <input type="button" value="FUNC"/>	CO value setting	<i>Hold</i>	ON or OFF	HOLD lamp flicker	
↓ <input type="button" value="FUNC"/>	Temperature measurement selection (option)	<i>LOC.</i>	ON or OFF		10
<input type="radio"/> ZERO	Temperature measurement (option)	Measured value	Range	Zero key display lamp flicker	10
<input type="radio"/> SPAN	Key lock selection	Measured value	Range	Span key display lamp flicker	11

Zero calibration

Span calibration

- In setting mode, analog output signal is held to the value prior to the setting mode.
- When option function is not provided, data of that function is not displayed.

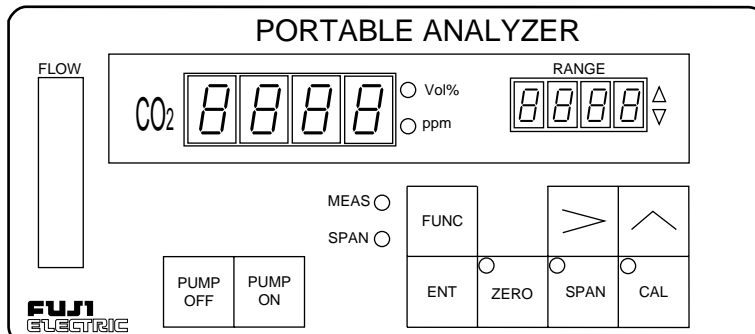

5.2 General operation



DANGER

- When handling the standard gas such as calibration gas, read the instruction manual of the standard gas carefully and use the gas correctly.



CAUTIONS

- Avoid continuous operation with the casing drawn out.
- During operation, avoid opening the casing and touching the internal parts. Otherwise, you may suffer a burn or shock hazard.
- The analyzer is set in measurement mode at ON of power switch. At this time, measured gas concentration is shown on the main display.
- Before starting measurement, be sure to calibrate zero and span at low and high ranges.

Advice on operation

To change set value

Press key and select your desired digit. The selected digit will flicker.

Press key and change the set value.

Press key and store the set value which has been changed in memory.

Releasing zero and span:

In case of incorrect operation during zero/span calibration, release zero/span using the following procedure.

If key is pressed by mistake when key is to be pressed, press key again and calibration can be released.

If key is pressed by mistake when key is to be pressed, press key again and calibration can be released.

5.2.1 Calibration concentration setting

Calibration gas concentration (span value) can be set.

By pressing **FUNC** key in measurement mode, the preset span value is shown on the main display and the function lamp 「SPAN」 LED flickers. After selecting range, press **>** and **^** keys to set span. The set value is stored in memory at press of **ENT** key.

[Adjustment at each range]

Perform the following operation and setting.

Make sure that the maximum digit flickers on the main display, then press **CAL** key. 「SCALE」 is shown on the main display and 「ON」 is shown on the sub display.

By pressing **^** key, it is switched to 「OFF」.

Meaning of set value

OFF: Effective only for that range; span can be calibrated independently on each range.

ON: When span is calibrated on 1 range, those of other ranges are also calibrated in succession.

After selecting, press **ENT** key. Setting operation is now completed.

Note) When measured gas contains H₂ gas, its concentration affects the span point. In this case, use a standard gas (measured gas / H₂ / N₂) which contains the same H₂ gas as contained in the measured gas or use the value corrected from the attached test report as a span value.

Note) When measured gas is being supplied, the indications of low and high ranges may not correspond with each other within the accuracy of linearity.

5.2.2 Key lock ON/OFF setting

This is a function to prevent the analyzer from operating by mistake.

When the key lock is set in 「ON」 position, any keys other than **FUNC** key cannot be used. To release this function, set it to 「OFF」.

Press **FUNC** key 3 times in measurement mode to indicate 「LOC」.

The key lock can be set by pressing **>** key. At this time, the sub display flickers. Press **^** key to set key lock ON/OFF.

After setting the key lock, press **ENT** key. The setting operation is now completed

5.2.3 Zero calibration

Zero calibration is used to adjust zero point after the pump turns OFF.

With zero gas N₂ applied in measurement mode, press **ZERO** key.

The **ZERO** key lamp flickers and the main display shows measured gas concentration.

After the indication is stabilized, press **CAL** key to start zero calibration. During calibration, the **CAL** key lamp is ON.

The analyzer returns to measurement mode at the completion of calibration. The zero point is fixed to 0 Vol%.

5.2.4 Span calibration

Span calibration is made using calibration gas having a concentration which has been set as a span value.

With the pump turned OFF, apply a calibration gas and press **SPAN** key. The **SPAN** key lamp flickers and the gas concentration is shown on the main display.

When the indication becomes stable, span can be calibrated by pressing **CAL** key. The **CAL** key lamp is ON during calibration.

After calibration, the analyzer is set in measurement mode.

Be sure to perform zero calibration before making span calibration.

Note 1) Apply zero gas and span gas using the following procedure.

① Use of canned standard gas

Remove the cap from the calibration gas inlet, and insert the nozzle of the canned standard gas straight down into the inlet. By pressing the bottom of the can, the standard gas flows into the analyzer.

When the indication changes, stop pressing the bottom of the can and wait until the indication is stabilized.

Next, press and stop quickly and repeatedly, and confirm that the indication does not rise anymore and becomes constant. When calibration with **CAL key is finished, remove the can from the calibration gas inlet.**

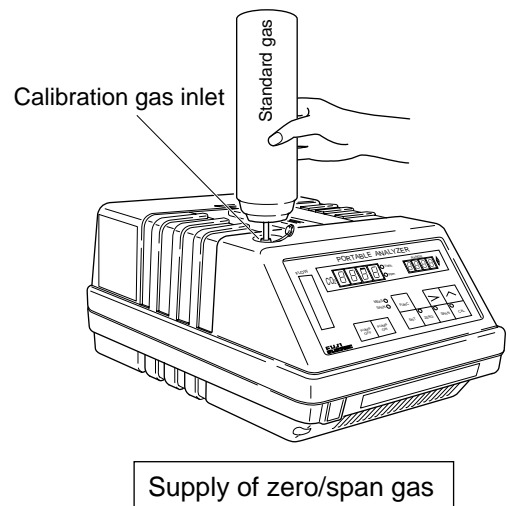

② Use of standard gas cylinder

- **Connect a pressure reducing valve to the standard gas cylinder, then connect the supplied calibration gas injector to the piping and insert it into the calibration gas inlet or connect the piping directly to the sample inlet.**
- **When connecting the secondary pressure of the reducing valve to the calibration gas injection port after opening the standard gas main valve, set it to 1.5 to 2kgf/cm² (0.15 to 0.2MPa) or when connecting it to the sample inlet, set it to 0.2kgf/cm² (20kPa) and adjust the flow rate with the reducing valve so that it enters the white zone of the flow meter.**

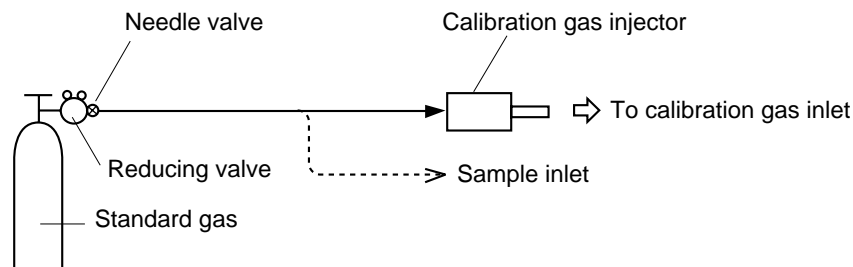

Note 2) When the power frequency changes (50 ⇔ 60Hz), a drift of a few %FS will arise. This is normal and is not an indication of trouble. Please use it after calibration.

6. INSPECTION AND MAINTENANCE



DANGER

- When doors are open during maintenance or inspection for adjusting the optical system, etc., be sure to purge sufficiently the inside of the gas analyzer as well as the measuring gas line with nitrogen or air, in order to prevent poisoning, fire or explosion due to gas leaks.



CAUTIONS

- Before working, take off a wrist watch, finger ring or the like metallic accessories. And never touch the instrument with a wet hand, Otherwise, you will have a shock hazard.
- If the fuse is blown, eliminate the cause, and then replace it with the one of the same capacity and type as before. Otherwise, shock hazard or fault may be caused.
- Do not use a replacement part other than specified by the instrument maker. Otherwise, adequate performance will not be provided. Besides, an accident or fault may be caused.
- Replacement parts such as a maintenance part should be disposed of as incombustibles.

6.1 Routine inspection and maintenance

(1) Check on flow rate

Make sure that the float of the flow monitor is above the white zone. If it is below the white zone, check the pump piping for looseness (remove 6 cover fixing screws from the bottom and remove the cover).

(2) Inspection of filter paper (membrane filter element)

- ① Inspection should be made prior to initial measurement whenever measurements are required.

First check the filter paper visually for contamination.

If it has turned black or is wet with water or oil, replace it with a new one.

Failure to observe this inspection and maintenance can result in damage to the filter paper which causes entry of dust into the analyzing unit, whereby correct measurements are not available.

Filter paper should be replaced every 2 to 3 days.

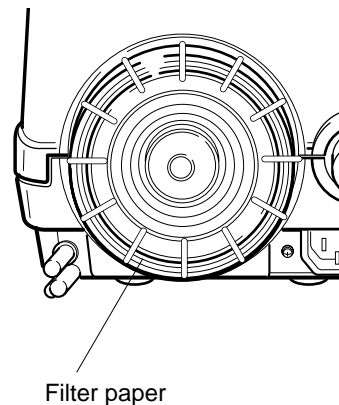

② Replacement of filter paper

Make sure that the pump switch is OFF. Then, turn the membrane filter cover counterclockwise and remove the filter paper from the unit.

Next, remove the inner O-ring and take out the soiled paper. At this time, check that the unit is free from paper dust or foreign objects. Set a new filter paper in place and hold it with the inner O-ring at the texture side.

The inner O-ring should be fitted to membrane filter while pressing it with hand or with a flat object.

Finally, attach the lid of the membrane filter to the threaded section and turn it clockwise until it is locked firmly.

When it is difficult to remove the lid, apply a thin coat of vacuum grease or silicon grease to the outer O-ring.

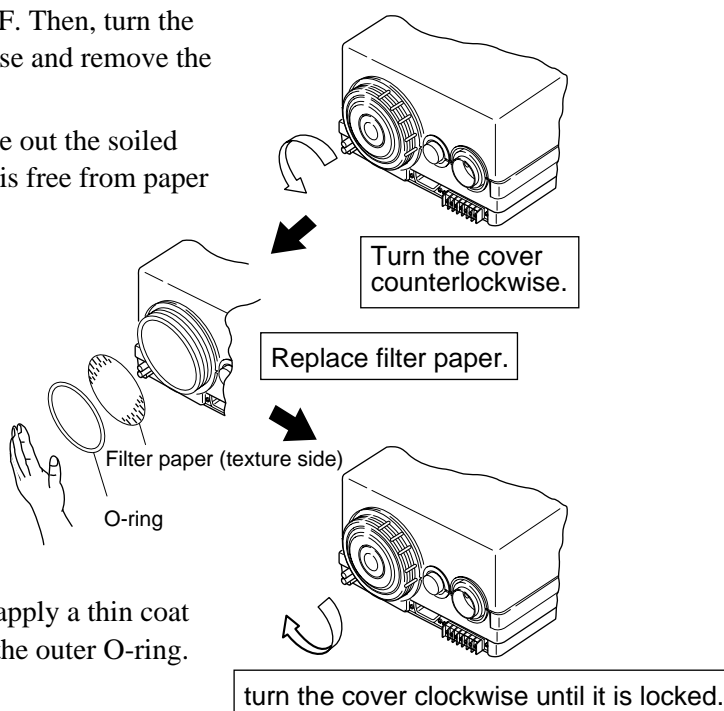

③ Cleaning of membrane filter case

The membrane filter case should be cleaned with a piece of cloth moistened with water or cleaning solvent, then a thin coat of vacuum grease or silicon grease should be applied to the filter case.

When cleaning the inside of the filter case, special care should be taken to prevent entry of dust into its gas outlet.

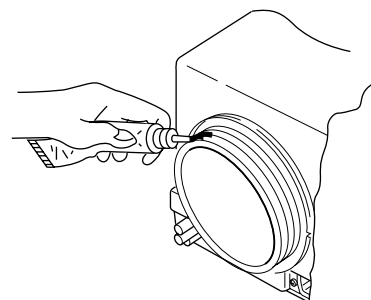

6.2 Cleaning of measuring cell

Entry of dust or water drops into the measuring cell may cause a drift due to contamination inside the measuring cell. If the inside of the cell is contaminated, it needs to be cleaned.

At this time, be sure to check the sampling devices (filter, etc.) to keep the inside of the cell from contamination with dust and mist.

6.2.1 Disassembly/reassemble of measuring cell

(1) Removal of cell

- ① Stop the measured gas. When it contains a harmful gas, the inside of the measuring cell should be purged sufficiently using zero gas or air.
- ② Turn OFF the power switch.
- ③ Remove 6 cover fixing screws from the bottom and then remove the cover.
- ④ Remove the piping from the measuring cell.
- ⑤ Remove the sensor output cord connector from the printed circuit board.
- ⑥ Loosen the 2 sensor fixing screws holding the infrared-ray light source unit and remove the sensor from the measuring unit.

The cell is assembled with the sensor.

- ⑦ Loosen 2 cell fixing screws holding the sensor and remove the cell. The window on one side of the cell is loosely fitted between the sensor and cell. Remove it carefully not to drop it with sensor facing upward.
- ⑧ To reassemble the measuring cell, follow the disassembling procedure in reverse order. The O-ring should be placed between the window holder and the cell. Make sure that the O-ring is positioned correctly.

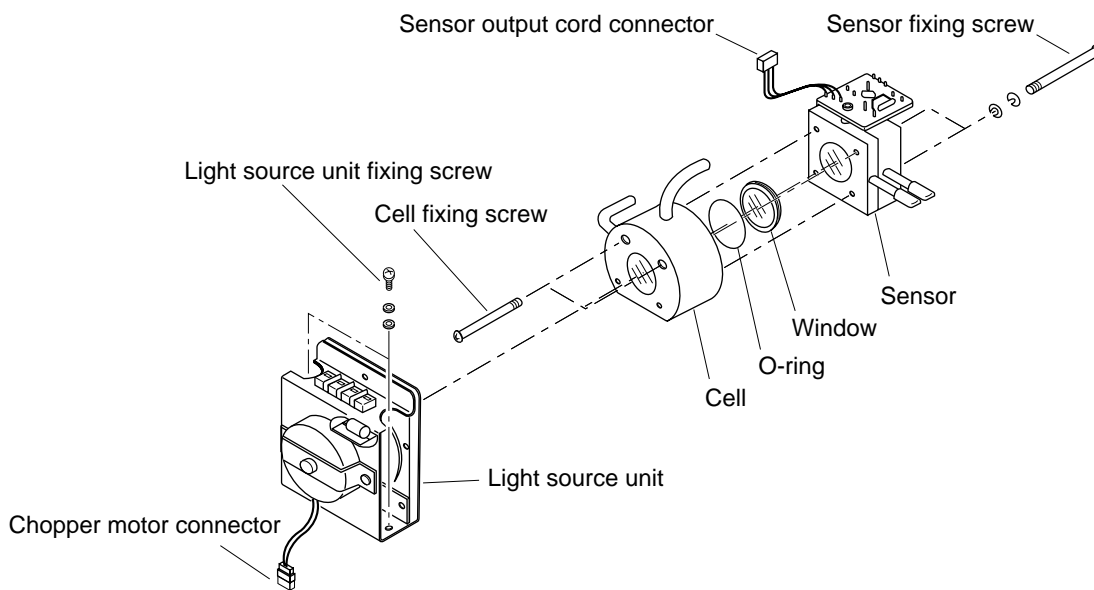

(2) Drain discharge

When the drain separator is filled with drain, remove the drain plug and discharge the drain. After discharging, insert the plug firmly and tighten it with the hose band.

6.2.2 Cell cleaning procedure

- ① To clean the inside of the cell or the infrared-ray transmission window, roughly remove dust with a soft brush and then wipe with a soft cloth. Do not use a hard cloth.

Note) The window is easily damaged so special care should be taken when handling it. Do not rub it forcibly to avoid scratching.

- ② If the window is badly contaminated, use a soft cloth moistened with alcohol, acetone or other solvents.
- ③ If the window is corroded, use a soft cloth and chrome oxide powder. If it is badly corroded, it needs to be replaced.
- ④ After cleaning the cell or the window, reassemble it referring to Item 6.2.1 Disassembly/reassembly of measuring cell. The piping should be connected tightly to prevent air leaks. Also, abnormal bends of piping should be corrected.

7. ERROR CODE AND REMEDY



DANGER

- If the cause of any fault cannot be determined despite reference to the instruction manual, be sure to contact your dealer or Fuji Electric's technician in charge of adjustment. If the instrument is disassembled carelessly, you may have a shock hazard or injury.

The analyzer has a self-check functions. If trouble arises in the analyzer, it is indicated by error code.

Error code	Trouble	Remedy
E-0 E-1	Trouble in digital unit	Press ENT key and the display of error code will disappear. When the error code is not displayed thereafter, make sure that the display and output are normal at the time flowing zero or span gas. If error code is displayed again at a press of ENT key, turn OFF and ON the power. When error code is still displayed, the printed circuit board needs to be replaced. Contact your nearest Fuji Electric's service station.
E-2 E-3	Trouble in temperature sensor signal processing system	
E-4 E-5	Amount of calibration exceeds the calibration limit due to drift	Clean the inside of the cell referring to Item 6.2. If calibration can not still be made after cleaning, the sensor and other units need to be checked. Contact your nearest Fuji Electric's service station.
E-5	Amount of zero calibration exceeds 50% of measurement range	
E-6	Amount of span calibration exceeds 50% of measurement range	Make sure that the span concentration set value corresponds to the span gas concentration.

1. Error code is shown on the sub display.
2. When trouble corresponds to two or more error codes, they are displayed in order, starting from the small number of code at press of **ENT** key. When **ENT** key is pressed again after all the error codes are displayed, the error display disappears but error is displayed again if trouble is still present.
3. When the cause of error is removed, the analyzer will operate properly but the error code is still displayed to indicate the occurrence of trouble. The error display goes off by pressing **ENT** key.
4. When an error code appears, first check that the power source and gas piping are normal.
5. When error display does not go off or error is displayed frequently, contact your nearest Fuji service station.

8. SPECIFICATIONS AND PERFORMANCE

- Principle of measurement : NDIR (non-dispersive infrared system)
- Measurement components and range :

Measurement components Measurement range	CO ₂	CO	CH ₄
0 to 0.2/0.5%	○	×	×
0 to 0.5/1.0%	○	○	×
0 to 1.0/2.0%	○	○	○
0 to 2.0/5.0%	○	○	○
0 to 5.0/10.0%	○	○	○
0 to 10.0/20.0%	○	○	×
0 to 20.0/50.0%	○	○	×
0 to 50.0/100.0%	○	×	×

- Repeatability : $\pm 0.5\%$ FS
- Drift : Zero/span, $\pm 2.0\%$ FS/day (indication value)
- Linearity : $\pm 2\%$ FS
- Response : 90% response, 15sec or less
- Sample flow rate : About 1 ℓ /min (pump, filter, built-in flow meter)
- Analog output : 4 to 20mA DC (allowable load, 550Ω or less)
- Indicator : 4 digits digital indication
- Calibration : One-touch calibration with canned gas or compressed standard gas cylinder (ø6 tube connecting attachment is supplied)
- Warm-up time : About 30min
- Power source : 100V AC ± 10 V 50/60Hz, about 40VA (power cord is supplied)
- Sample gas condition : Dust; 0 to 10mg/Nm³ (for continuous measurement, a filter should be mounted on its front stage)
Sample temperature; 50°C or less at analyzer inlet
Pressure; -2.94 to +2.94kPa {-300 to +300mmH₂O}
- Installation condition : Temperature; 0 to 40°C
Humidity; 90%RH or less
Installation place; indoors (do not install near combustion exhaust gas, install on level stand, etc.)
- Case : Plastic, portable type (with ventilation hole)
- Dimensions : 170 × 260 × 375mm (H × W × D)
- Mass : 5kg or less
- Scope of delivery : Main unit ----- × 1
Power cord ----- × 1
Power fuse (tube type; 1A, ø6.4 × 30)----- × 1
Filter paper ----- × 25
Calibration gas piping connecting joint ----- × 1
Main body vinyl cover ----- × 1
ø9/5 elastic tube, 5cm (for ø6 tube connection) ---- × 1
Hose band (ø10) ----- × 2
- Option : Zero/span calibration standard gas (Type: ZBM. 1 ℓ canned gas (12 cans))

• Type :

1	2	3	4	5	6	7	8	9 Digit	Description
Z	F	Y					1		Measurement components (4th digit) CO ₂ CO CH ₄
			D						
			B						
			E						Measurement range (5th digit) G 0 to 0.2/0.5% (CO, CH ₄ not available) H 0 to 0.5/1.0% (CH ₄ not available) J 0 to 1.0/2.0% K 0 to 2.0/5.0% L 0 to 5.0/10.0% M 0 to 10.0/20.0% (CH ₄ not available) N 0 to 20.0/50.0% (CH ₄ not available) P 0 to 50.0/100.0% (CO, CH ₄ not available)
				G					
				H					
				J					
				K					
				L					
				M					
				N					
				P					
						1			Output signal (6th digit) DC4 to 20mA
							1		Power source (7th digit) AC100V 50/60Hz
								A	Application (9th digit) For general-use (combustion exhaust gas, green house, atmosphere)
								B	For C ₄ H ₁₀ , C ₃ H ₈ degenerated thermal processing furnace gas (with about 30%H ₂)
								C	For CH ₃ OH degenerated thermal processing furnace gas (with about 65% H ₂)
								D	For ceramic industry

Outline diagram

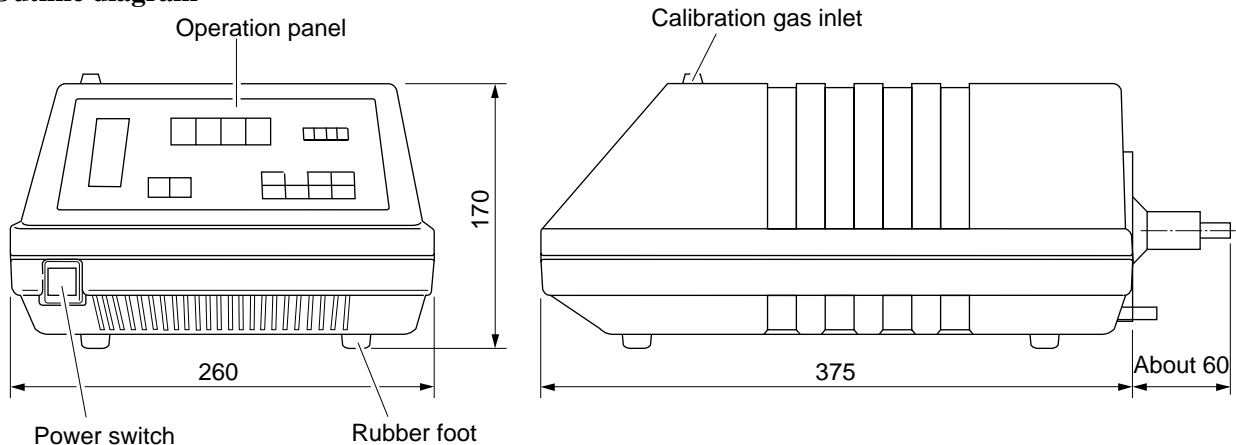

Front view

Side view

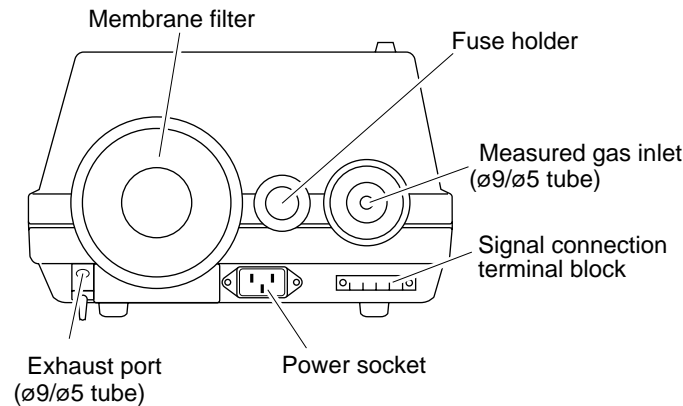

Rear view

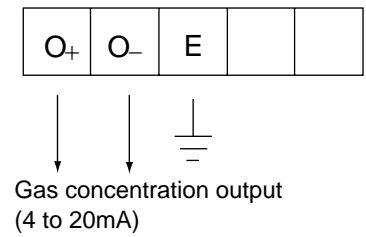

Connection diagram

Fuji Electric Systems Co., Ltd.

Head Office

Gate City Ohsaki, East Tower, 11-2, Osaki 1-chome,
Shinagawa-ku, Tokyo 141-0032, Japan
<http://www.fesys.co.jp/eng>

Instrumentation Div.

International Sales Dept.

No.1, Fuji-machi, Hino-city, Tokyo 191-8502, Japan
Phone: 81-42-585-6201, 6202 Fax: 81-42-585-6187
<http://www.fic-net.jp/eng>
