

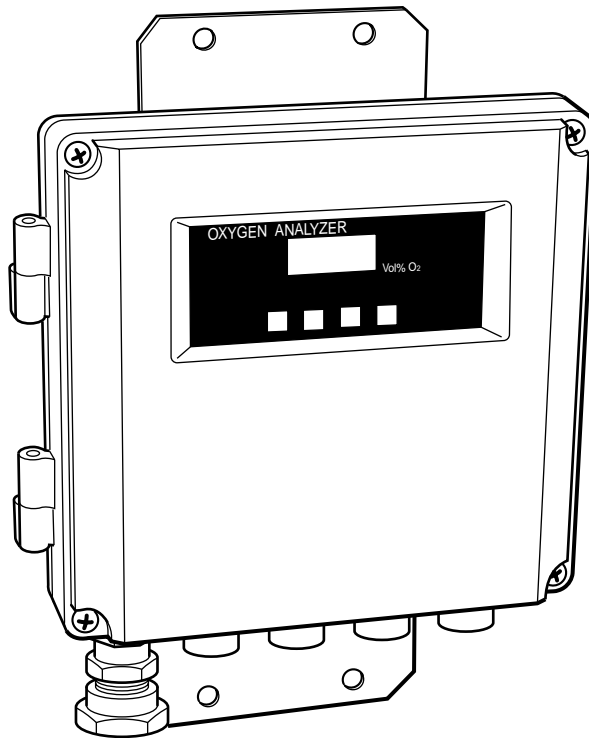

## Instruction Manual

# ZIRCONIA OXYGEN ANALYZER CONVERTER

TYPE: ZRY



# PREFACE

---

We are grateful for your purchase of Fuji Zirconia Oxygen Analyzer Converter (ZRY).

- First read this instruction manual carefully until an adequate understanding is acquired, and then proceed to installation, operation and maintenance of the analyzer converter. Wrong handling may cause an accident or injury.
- The specifications of this analyzer converter will be changed without prior notice for further product improvement.
- Modification of this analyzer converter is strictly prohibited unless a written approval is obtained from the manufacturer. Fuji will not bear any responsibility for a trouble caused by such a modification.
- This instruction manual shall be stored by the person who actually uses the analyzer converter.
- After reading the manual, be sure to store it at a place easier to access.
- This instruction manual should be delivered to the end user without fail.

Manufacturer : Fuji Electric Instrumentation Co., Ltd.  
Type : Described in nameplate on main frame  
Date of manufacture : Described in nameplate on main frame  
Product nationality : Japan

## Request

- It is prohibited to transfer part or all of this manual without Fuji's permission in written format.
- Description in this manual will be changed without prior notice for further improvement.



© Fuji Electric Systems Co., Ltd. 2005

Issued in May, 2005



# CAUTION ON SAFETY

**First of all, read this “Caution on safety” carefully, and then use the analyzer in the correct way.**

- The cautionary descriptions listed here contain important information about safety, so they should always be observed. Those safety precautions are ranked 2 levels; DANGER and CAUTION.

|  |   |
|--|---|
|  <b>DANGER</b>  | Wrong handling may cause a dangerous situation, in which there is a risk of death or heavy injury.  |
|  <b>CAUTION</b> | Wrong handling may invite a dangerous situation, in which there is a possibility of medium-level trouble or slight injury or only physical damage is predictable. |

- Even an undesirable action described in “  **CAUTION** ” may lead to a grave result depending on situation. Be sure to observe DANGER and CAUTION because they are both important for ensuring safety.

| <b>Caution on installation and transport of gas analyzer</b>                                       |  |
|--|--|
|  <b>DANGER</b>   | <ul style="list-style-type: none"> <li>• This unit is not explosion-proof type. Do not use it in a place with explosive gases to prevent explosion, fire or other serious accidents.</li> </ul>  |
|  <b>CAUTION</b> | <ul style="list-style-type: none"> <li>• This unit should be installed in a place which conforms to the conditions noted in the instruction manual. Otherwise, it may cause trouble or malfunction of the unit.</li> <li>• During installation work, care should be taken to keep the unit free from entry of cable chips or other foreign objects. Otherwise, it may cause fire, trouble or malfunction of the unit.</li> <li>• For installation, observe the rule on it given in the instruction manual and select a place where the weight of gas analyzer can be endured.<br/>Installation at an unsuited place may cause turnover or fall and there is a risk of injury.</li> <li>• For lifting the gas analyzer, be sure to wear protective gloves. Bare hands may invite an injury.</li> <li>• Before transport, fix the casing so that it will not open. Otherwise, the casing may be separated and fall to cause an injury.</li> <li>• The gas analyzer is heavy. It should be transported carefully by two or more persons if manually required. Otherwise, body may be damaged or injured.</li> </ul> |

| <b>Caution on wiring</b>  |   |
|---|---|
|  <b>DANGER</b> | <ul style="list-style-type: none"> <li>• If leaked gas contains oxygen at a high concentration, there is a risk of fire.</li> <li>• Connect pipes correctly referring to the instruction manual. Wrong piping may cause gas leakage.</li> </ul> |

| <b>Caution on wiring</b>   |   |
|--|---|
|  <b>CAUTION</b> | <ul style="list-style-type: none"> <li>• The unit must be earthed as specified. Otherwise, it may cause electric shocks, malfunction, etc.</li> <li>• Be sure to use a power supply of correct rating. Connection of power supply of incorrect rating may cause fire.</li> <li>• Wiring work must be performed with the main power set to OFF to prevent electric shocks.</li> <li>• Use wiring materials that match the rating of the unit. Use of wiring materials out of rating may cause fire.</li> </ul> |

| <b>Caution on use</b>  |   |
|--|---|
|  <b>CAUTION</b> | <ul style="list-style-type: none"> <li>• During operation, avoid opening the casing and touching the internal parts. Otherwise, you may suffer a burn or shock hazard.</li> <li>• Avoid touching the detector with bare hand during operation. Otherwise, you may suffer a burn because the detector may have reached a high temperature (about 800°C).</li> <li>• During operation, avoid removing and placing the detector on or near a combustible material. Otherwise, fire may occur.</li> </ul> |

| <b>Caution on maintenance and check</b>  |  |
|--|--|
|  <b>CAUTION</b> | <ul style="list-style-type: none"> <li>• Before maintenance and check, be sure to turn off the main power supply and wait until the detector is cooled adequately. Otherwise, you may suffer a burn.</li> <li>• Before removing the detector from the flue for maintenance and check, make sure the furnace is stopped. Otherwise, you may suffer a burn.</li> <li>• Before working, take off a wrist watch, finger ring or the like metallic accessories. And never touch the instrument with a wet hand. Otherwise, you will have a shock hazard.</li> <li>• If the fuse is blown, eliminate the cause, and then replace it with the one of the same capacity and type as before. Otherwise, shock hazard or fault may be caused.</li> </ul> |

| <b>Others</b>  |   |
|--|---|
|  <b>CAUTION</b> | <ul style="list-style-type: none"> <li>• If the cause of any fault cannot be determined despite reference to the instruction manual, be sure to contact your dealer or Fuji's technician in charge of adjustment. If the instrument is disassembled carelessly, you may have a shock hazard or injury.</li> <li>• Do not use a replacement part other than specified by the instrument maker. Otherwise, adequate performance will not be provided. Besides, an accident or fault may be caused.</li> <li>• Replacement parts such as a maintenance part should be disposed of as incombustibles, or in accordance with the local-waste requirement.</li> </ul> |

# CONTENTS

---

|  |    |
|--|----|
| PREFACE .....  | i  |
| CAUTION ON SAFETY .....                                  | ii |
| CONTENTS .....   | iv |
| 1. GENERAL DESCRIPTION .....                             | 1  |
| 1.1 Direct insertion type zirconia oxygen analyzer ..... | 1  |
| 1.2 Confirmation of delivered components .....           | 1  |
| 1.3 Confirmation of type of delivered components .....   | 1  |
| 2. NAME AND FUNCTION OF EACH PART .....                  | 2  |
| 2.1 Name and function of converter part .....            | 2  |
| 2.2 Name and function of display and control panel ..... | 2  |
| 3. INSTALLATION .....                                    | 3  |
| 3.1 Location for installation .....                      | 3  |
| 3.2 Installation .....                                   | 3  |
| 3.2.1 Panel mounting .....                               | 3  |
| 4. WIRING AND PIPING .....                               | 4  |
| 4.1 Before wiring .....                                  | 4  |
| 4.2 Wiring to each terminal .....                        | 4  |
| 4.3 Wiring and piping diagram .....                      | 5  |
| 5. PREPARATION FOR OPERATION .....                       | 6  |
| 6. OPERATION AND STOP .....                              | 7  |
| 6.1 Starting .....                                       | 7  |
| 6.2 Shutdown .....                                       | 7  |
| 6.3 Key operation flow diagram (outline) .....           | 8  |
| 6.4 Check on alarm data .....                            | 9  |
| 6.5 Oxygen detector standard output .....                | 10 |
| 7. SETTING OF CALIBRATION GAS CONCENTRATION .....        | 11 |
| 7.1 How to set span calibration gas concentration .....  | 11 |
| 7.2 How to set zero calibration gas concentration .....  | 11 |
| 8. CALIBRATION .....                                     | 12 |
| 8.1 Preparation .....                                    | 12 |
| 8.2 Manual calibration .....                             | 12 |
| 9. RANGE SELECTION .....                                 | 13 |

---

|  |    |
|--|----|
| 10. ADJUSTMENT .....                               | 14 |
| 10.1 Zirconia input signal adjustment .....        | 14 |
| 10.2 Temperature input adjustment .....            | 15 |
| 10.3 Current output adjustment .....               | 16 |
| 10.4 Setting of detector control temperature ..... | 17 |
| 10.5 Selection of alarm contact output .....       | 18 |
| 11. MAINTENANCE AND CHECK .....                    | 19 |
| 11.1 Check .....                                   | 19 |
| 11.2 Fuse replacement .....                        | 19 |
| 11.3 Troubleshooting .....                         | 20 |
| 12. APPENDIX .....                                 | 21 |
| 12.1 Specification .....                           | 21 |
| 12.2 Designation of type (PILC code table) .....   | 23 |
| 12.3 Outline diagram (unit:mm) .....               | 25 |

# 1. GENERAL DESCRIPTION

This instruction manual describes the installation, operation and maintenance of the single-channel type converter, so read through it before using the converter. For the sensor, flow guide tube used with the converter, refer to relevant instruction manuals.

## 1.1 Direct insertion type zirconia oxygen analyzer

The direct insertion type zirconia oxygen analyzer consists of a direct insertion type zirconia detector (type ZFK) and converter (type ZRY).

It is used to measure oxygen concentration in waste gas during combustion for controlling gas combustion.

## 1.2 Confirmation of delivered components

Inspect the external appearance and number of accessories to confirm there is no damage or shortage of parts

### List of components and accessories

- Converter  
Accessories of converter
- Power fuse (0.5A) ----- 1
  - Heater fuse (3A) ----- 1

### CAUTION

Power voltage for the converter must conform to that for the detector (ZFK2 or 5) to be connected. Don't use any power voltage different from the power specifications of the detector.

Because it may result in damage to the sensor.

100 to 115V AC for ZFK 

|                          |                          |                          |                          |   |   |
|--------------------------|--------------------------|--------------------------|--------------------------|---|---|
| <input type="checkbox"/> | <input type="checkbox"/> | <input type="checkbox"/> | <input type="checkbox"/> | 1 | 4 |
| <input type="checkbox"/> | <input type="checkbox"/> | <input type="checkbox"/> | <input type="checkbox"/> |   |   |

200 to 240V AC for ZFK 

|                          |                          |                          |                          |                          |   |
|--------------------------|--------------------------|--------------------------|--------------------------|--------------------------|---|
| <input type="checkbox"/> | <input type="checkbox"/> | <input type="checkbox"/> | <input type="checkbox"/> | <input type="checkbox"/> | 4 |
| <input type="checkbox"/> | <input type="checkbox"/> | <input type="checkbox"/> | <input type="checkbox"/> | <input type="checkbox"/> |   |

## 1.3 Confirmation of type of delivered components

Check model name on specification nameplate to confirm that the delivered components are as described in Item 12.2 Designation of type (PILC code table).

## 2. NAME AND FUNCTION OF EACH PART

### 2.1 Name and function of converter part

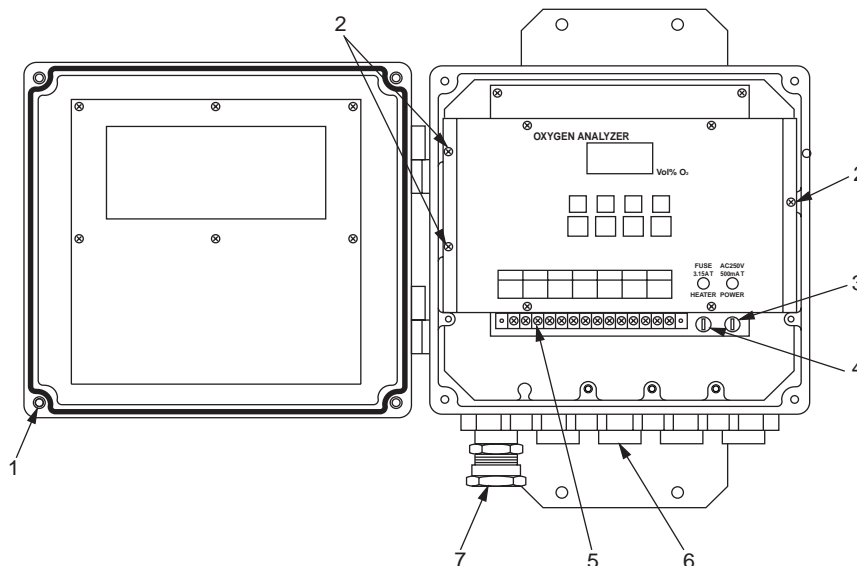

| No. | Name                                    | Function  |
|-----|---|---|
| (1) | Cover fixing screw (4 places)           | Screw for opening or closing the cover.   |
| (2) | Operation panel fixing screw (3 places) | Screw for fixing the operation panel to the case.   |
| (3) | Fuse (0.5A)                             | Fuse for the power supply of the converter.   |
| (4) | Fuse (3A)                               | Fuse for the heater for O <sub>2</sub> sensor.  |
| (5) | Terminal block                          | Connect cables from external equipments.  |
| (6) | Cable inlet                             | Use to insert external cable.   |
| (7) | Cable gland                             | Cable inlet to insert the exclusive cable for the sensor.<br>(For $\phi 23.5/\phi 15.8$ ) |
| (8) | Selector valve                          | Selects zero or span gas (available at option).   |

### 2.2 Name and function of display and control panel

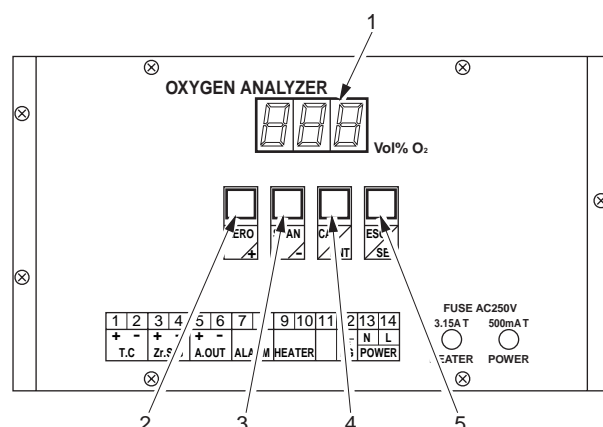

| No. | Name                               | Function   |
|-----|------------------------------------|--|
| (1) | Measured gas concentration display | Indicates oxygen gas concentration and alarm status.<br>Refer to each operation procedure flow in chapters 6, 10 and 11. |
| (2) | ZERO key                           |  |
| (3) | SPAN key                           |  |
| (4) | CAL key                            |  |
| (5) | ESC key                            |  |

### 3. INSTALLATION

#### ⚠ CAUTION

- Install the analyzer safely and securely so that it will not fall.

#### 3.1 Location for installation

To install the analyzer for optimum performance, select a location that meets the following conditions;

- (1) Space for routine inspection and wiring available.
- (2) Vibration, dust, dirt and humidity are minimal.
- (3) No direct influence of radiation from heating furnace or the like (converter).
- (4) Non-corrosive atmospheric environment.
- (5) No electric machinery nearby, which may cause noise trouble (such as motor, transformer) or produce electromagnetic and electrostatic induction.
- (6) Ambient temperature within -10 to +50°C and ambient humidity less than 90%RH (converter).

#### 3.2 Installation

##### 3.2.1 Panel mounting

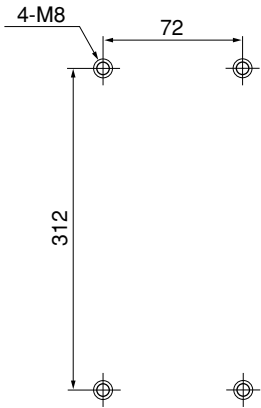
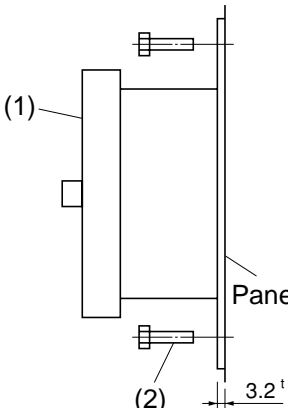
| Mounting dimension (unit; mm)   | Mounting method   |   |     |      |       |     |           |   |     |  |   |  |
|---|---|---|-----|------|-------|-----|-----------|---|-----|--|---|--|
|  |  | <table border="1"> <thead> <tr> <th>No.</th> <th>Name</th> <th>Piece</th> </tr> </thead> <tbody> <tr> <td>(1)</td> <td>Converter</td> <td>1</td> </tr> <tr> <td>(2)</td> <td>Hexagon headed bolt 4-M8<br/>( Excluded from the<br/>scope of supply )</td> <td>4</td> </tr> </tbody> </table> | No. | Name | Piece | (1) | Converter | 1 | (2) | Hexagon headed bolt 4-M8<br>( Excluded from the<br>scope of supply ) | 4 |  |
| No.   | Name  | Piece   |     |      |       |     |           |   |     |  |   |  |
| (1)   | Converter   | 1   |     |      |       |     |           |   |     |  |   |  |
| (2)   | Hexagon headed bolt 4-M8<br>( Excluded from the<br>scope of supply )                | 4   |     |      |       |     |           |   |     |  |   |  |

## 4. WIRING AND PIPING

### ⚠ CAUTION

- ⚠ • Wiring work must be carried out with all power supplies turned off. Otherwise, you may suffer electric shock.
- ⚡ • The analyzer should be grounded without fail (Class D grounding).

### 4.1 Before wiring

- (1) Power supply voltage to the converter should match with that of the sensor (Type ZFK2 or 5).
- (2) For wiring to the power supply, use 600V vinyl insulation power cable (JISC3307) of 1.25mm<sup>2</sup> or equivalent.
- (3) For grounding line, use 600 V vinyl insulation cable (JISC3307) of at least 2 mm<sup>2</sup> or equivalent.
- (4) For the wiring of thermocouple, be sure to use a compensating wire.
- (5) Exclusive cable (6 cores in total) between the sensor and converter should be installed in a cable conduit for protection. It should be separated from power cable for prevention of noise. For use of the exclusive cable, see Item 12.2 Designation of type.
- (6) Output signal cable should be separated more than 30cm away from power line to prevent effect of induction noise. Shielded cable (600 V vinyl insulation cable of 0.5 mm<sup>2</sup> or more) should be used and grounded at one point with an M4 screw using toothed washer.

**(Note) When connecting cables to external terminal block, recommended insulation sleeve solderless terminals should be used (for M4 screw).**

### 4.2 Wiring to each terminal

This analyzer is not equipped with a switch. Install a switch or circuit breaker externally.

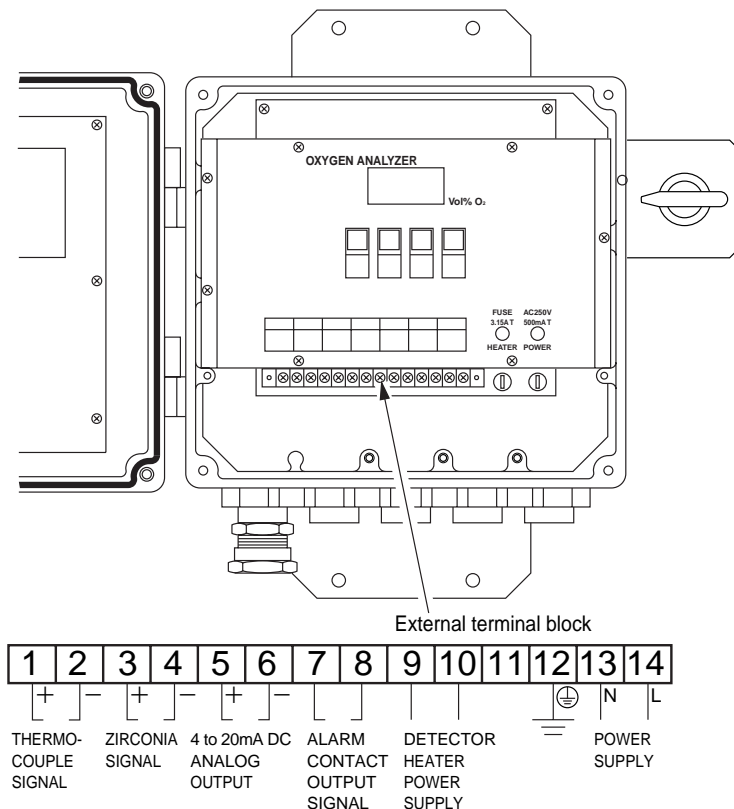

## 4.3 Wiring and piping diagram

### With flow guide tube

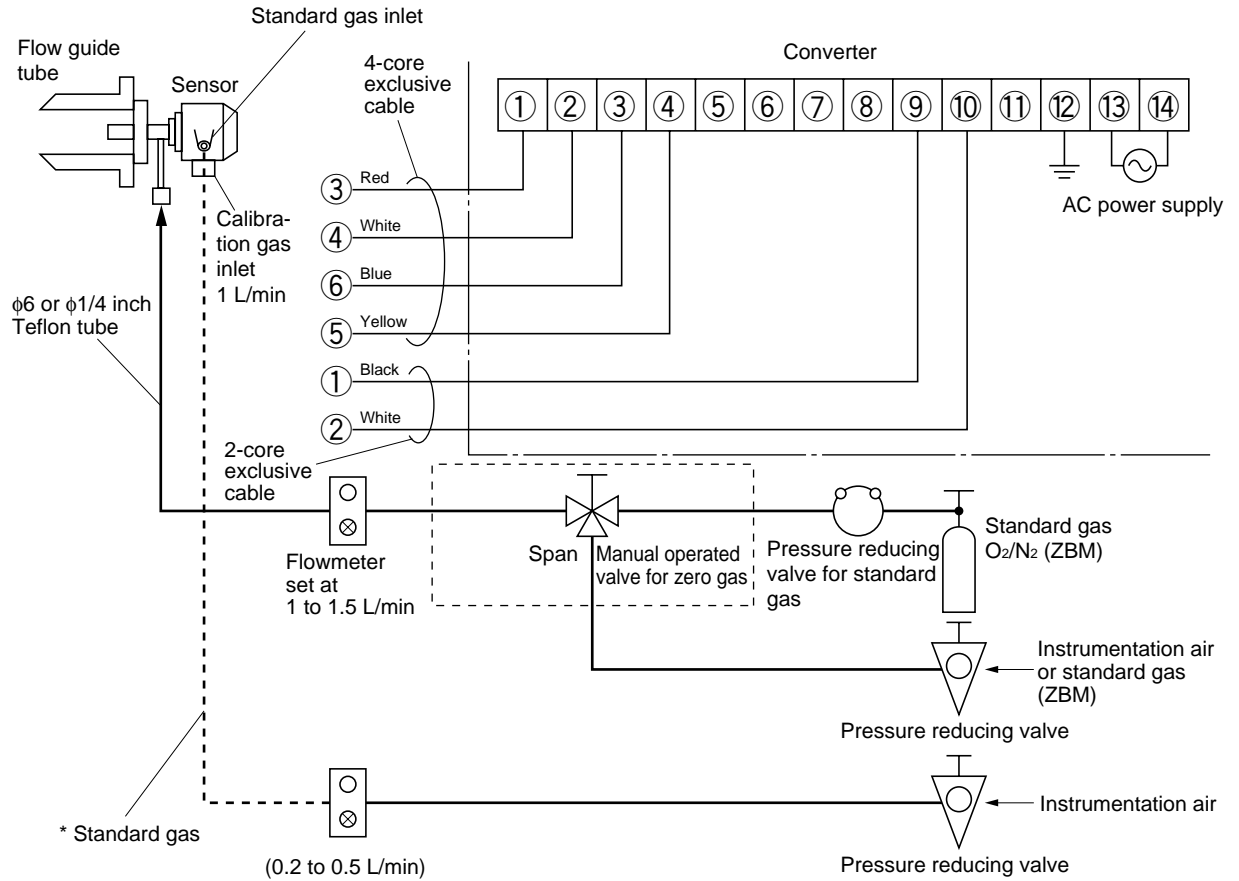

**\* Standard gas needs to be used for installation in an environment where oxygen gas concentration in the air around the sensor will change. This gas is not necessary in a usual installation environment.**

## 5. PREPARATION FOR OPERATION

---

Preparation can be performed after installation or on the bench.

(1) Wiring check (Refer to 4.2, 4.3)



(2) Confirmation of the power supply specifications (Confirm the specifications of the main power supply and voltage.)



(3) Piping check (Refer to 4.3)



(4) Power ON

- Turn ON the power.
- LED lighted.
- The analyzer is set in measurement display mode after warm-up (15 minutes).



(5) Warmup (After 15 minutes from power ON, accurate measurement data may be obtained.)



(6) Standard gas (composition gas) concentration setting  
For the standard gas concentration to be used, see Chapter 7.



(7) Calibration  
At the first operation, perform manual calibration after warmup using a calibration gas.  
Refer to chapter 8 for calibration procedures.



**Operation**

## 6. OPERATION AND STOP

---

### 6.1 Starting

After correct wiring and piping has been completed, turn the converter power ON, and measuring operation will start.

Until sensor temperature reaches the specified level after turning on the power supply, alarm is indicated (temperature alarm “L” flickers) and alarm contact is output. Warming-up takes about 15 minutes.

#### **Caution before starting operation**

- (1) Furnace operation should be started after 15 minutes. or more of warmup time has elapsed.
- (2) When a sensor is to be installed in a furnace during operation, take care to blow out harmful gas from the furnace and then install the fully warmed up sensor quickly.

### 6.2 Shutdown

#### **(1) When a process (furnace etc.) is to be shutdown for a short time (about one week)**

The sensor should be operated continuously. The inside of the sensor may become wet due to the internal atmosphere of a furnace. If power supply is turned ON in the wet status, the sensor may be damaged.

#### **(2) When a process (furnace etc.) is to be shutdown for a long time**

Turn OFF the analyzer after gas in the furnace has been replaced completely by ambient air.

## 6.3 Key operation flow diagram (outline)

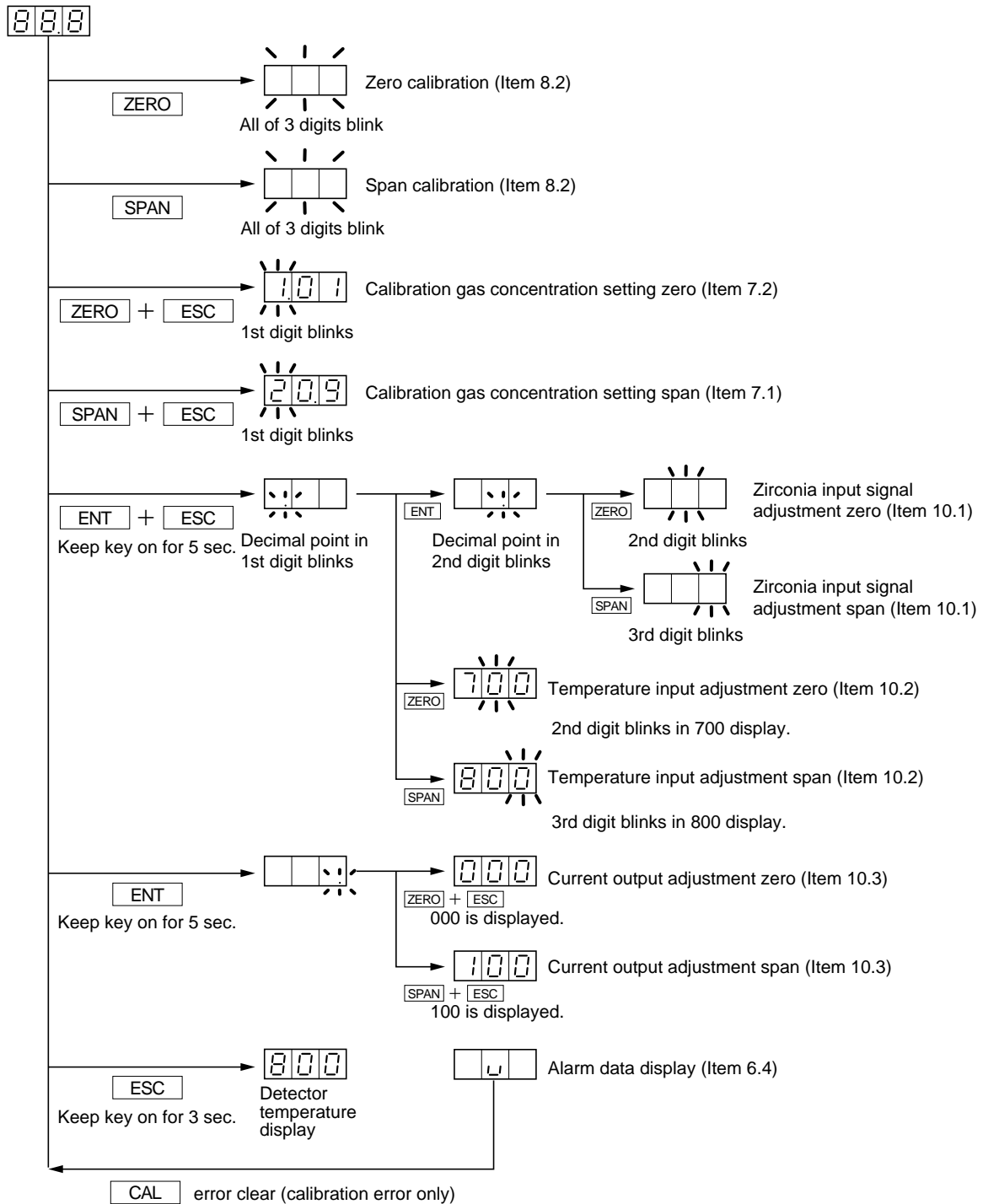

### Note) How to cancel operation

Press the **ESC** key during setting to cancel operation midway, returning to measurement display.

## 6.4 Check on alarm data

If an alarm occurs, a mark for indicating an abnormal measurement result flickers. At the same time, a fault (error) output appears between the error contact output terminals (Nos. 7 and 8) of the converter.

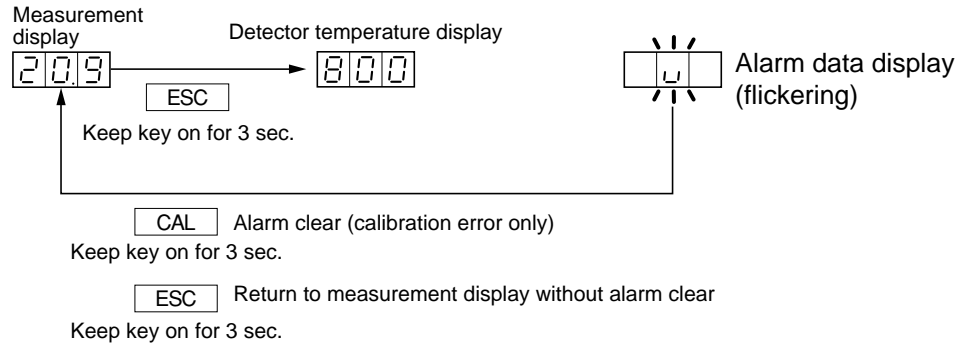

### (1) Alarm clear

After checking the contents of alarm, Press the **CAL** key for 3 seconds, and the alarm will be cleared in case of zero calibration error or span calibration error only. As a result, calibration value is reset to the original one. Check calibration gas concentration, tubing and flow rate, and then retry calibration.

#### Alarm data

|               |                        |   |   |
|---------------|------------------------|---|---|
|               | The 3rd digit          | H   | ; 50°C (or more) higher than the detector control temperature ..... Flickers ...  |
|               | Temperature error      | L   | ; 50°C (or less) lower than the detector control temperature ..... Flickers ...   |
|               | The 2nd digit          | L   | ; Difference of more than 5%O <sub>2</sub> between zero calibration gas concentration and zero calibration set value ..... Flickers ... |
|               | Zero calibration error | Blank   | ; Normal  |
| The 1st digit | L                      | ; Difference of more than 5%O <sub>2</sub> between span calibration gas concentration and span calibration set value ..... Flickers ... |   |
|               | Span calibration error | Blank   | ; Normal  |

### (2) Forced calibration

If a measured value is still abnormal despite alarm clearing, return from error display to measurement display by pressing the **ESC** key for 3 seconds. Then, check calibration gas, gas concentration, tubing and flow rate, and conduct a forced calibration. Repeat calibration until no alarm is issued.

#### Conditions of converter alarm contact output (between No.7 and No.8 terminals)

| The 5th digit of converter code symbols | Power OFF | Power ON, normal | Power ON, alarm |
|---|-----------|------------------|-----------------|
| B                                       | Open      | Open             | Closed          |
| C                                       | Open      | Closed           | Open            |

---

## 6.5 Oxygen detector standard output

| O <sub>2</sub> concentration % | Output value mV | O <sub>2</sub> concentration % | Output value mV | O <sub>2</sub> concentration % | Output value mV |
|--------------------------------|-----------------|--------------------------------|-----------------|--------------------------------|-----------------|
| 0.01                           | 168.15          | 5.0                            | 31.20           | 25.0                           | -4.266          |
| 0.1                            | 117.41          | 10.0                           | 15.93           | 30.0                           | -8.284          |
| 0.5                            | 81.94           | 15.0                           | 6.991           | 40.0                           | -14.623         |
| 1.0                            | 66.67           | 20.0                           | 0.651           | 50.0                           | -19.54          |
| 1.5                            | 57.73           | 20.6                           | 0               | ————                           | ————            |
| 2.0                            | 51.39           | 21.0                           | -0.4238         | ————                           | ————            |

## 7. SETTING OF CALIBRATION GAS CONCENTRATION



While setting zero/span calibration concentration, press the **ZERO** key once, then the number of the digit increases by one digit, and press the **SPAN** key, then the number of the digit decreases by one digit. Setting digit is moved to the right by one by pressing the **ENT** key. However, if the **ENT** is pressed while setting the 3rd digit, calibration concentration setting will be ended.

**Note)** Pressing the **ESC** key allows the setting to be canceled midway.

### 7.1 How to set span calibration gas concentration

#### Description

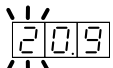
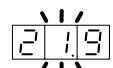
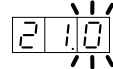
- Set span calibration gas concentration. Use air generally.
- For air, set 20.6% O<sub>2</sub>.
- The settable range is from 10.0 to 29.9% O<sub>2</sub>.

| Order  | Operation                | How to set the span calibration gas concentration to 21.0% O <sub>2</sub> .<br>(It is generally set to 20.9% O <sub>2</sub> before shipment). |  |
|--|--------------------------|---|--|
|  | Key operation            | Description   | Displayed message  |
| (1)  | <b>SPAN</b> + <b>ESC</b> | Press the <b>SPAN</b> key and <b>ESC</b> key simultaneously, then the lamp begins to blink (the number in the 1st digit blinks).              |                           |
| (2)  | <b>ENT</b> , <b>ZERO</b> | Press the <b>ENT</b> key to blink the 2nd digit. Press the <b>ZERO</b> key to change "0" to "1".  |                           |
| (3)  | <b>ENT</b> , <b>ZERO</b> | Press the <b>ENT</b> key to blink the 3rd digit. Press the <b>ZERO</b> key (increase) to change "9" to "0".                                   |                         |
| (4)  | <b>ENT</b>               | Press the <b>ENT</b> key, then the display set to 21.0 returns to measurement display status.   | <br>Measurement display |
| To cancel the setting, press the <b>ESC</b> key. |                          |   |  |

### 7.2 How to set zero calibration gas concentration

#### Description

- Set zero calibration gas concentration. Set the value specified on the gas cylinder.
- For zero gas, Use O<sub>2</sub> gas of 1.01% or less.
- The settable range is from 0.00 to 99.9% O<sub>2</sub>.

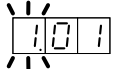
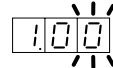
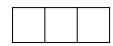
| Order  | Operation                                | How to set the zero calibration gas concentration to 1.00% O <sub>2</sub> .<br>(It is generally set to 1.01% O <sub>2</sub> before shipment). |  |
|--|--|---|--|
|  | Key operation                            | Description   | Displayed message  |
| (1)  | <b>ZERO</b> + <b>ESC</b>                 | Press the <b>ZERO</b> key and <b>ESC</b> key simultaneously, then the lamp begins to blink (the number in the 1st digit blinks).              |                         |
| (2)  | <b>ENT</b> , <b>ENT</b> ,<br><b>SPAN</b> | Press the <b>ENT</b> key twice to blink 3rd digit. Press the <b>SPAN</b> key (decrease) to change "1" to "0".                                 |                         |
| (3)  | <b>ENT</b>                               | Press the <b>ENT</b> key, then the display that is set to 1.00 returns to measurement display status.   | <br>Measurement display |
| To cancel the setting, press the <b>ESC</b> key. |  |   |  |

## 8. CALIBRATION

In order to maintain good accuracy, proper calibration using calibration gas is necessary.

Perform manual operation (Refer to 8.2).

### 8.1 Preparation

- Wiring/piping check  
Wiring and piping work should be made correctly referring to Item. 4.3. The main plug of standard gas should be left open. Since high pressure is present at piping connections, use blind-nut type joints and take special care with regard to air-tightness. Calibration gas flow should be 1 to 1.5L/min.
- Setting of calibration gas concentration  
Referring to Chapter 7 “Setting of calibration gas concentration,” set the oxygen concentration in standard gas cylinder to be used.

### 8.2 Manual calibration

#### Caution before operation

- Span/zero is calibrated once.
- Calibration should be performed in the order of span and zero.
- For calibration, allow calibration gas to flow into the sensor. When the sensor output signal is stabilized, key operation is performed to complete the processing.

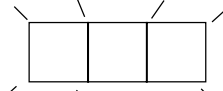
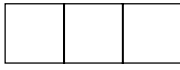
| Order   | Operation     | Performing span calibration.  |  |
|---|---------------|---|--|
|   | Key operation | Description   | Displayed message  |
| (1)   |               | Open the stop valve to flow span gas.   | <br>Measurement display     |
| (2)   | <b>[SPAN]</b> | Press <b>[SPAN]</b> , then the message at right appears. All of 3 digits blink.       | <br>(All of 3 digits blink) |
| (3)   | <b>[ENT]</b>  | When display is stabilized, press <b>[ENT]</b> key and span calibration is completed. | <br>Measurement display     |
| (4)   |               | Close the stop valve.   |  |
| To cancel span calibration, press the <b>[ESC]</b> key. |               |   |  |

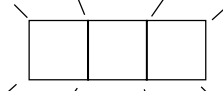
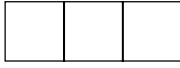
| Order   | Operation     | Open the stop valve to flow zero gas.   |  |
|---|---------------|---|--|
|   | Key operation | Description   | Displayed message  |
| (1)   |               | Open the stop valve to flow zero gas.   | <br>Measurement display     |
| (2)   | <b>[ZERO]</b> | Press <b>[ZERO]</b> , then the message at right appears. All of 3 digits blink.       | <br>(All of 3 digits blink) |
| (3)   | <b>[ENT]</b>  | When display is stabilized, press <b>[ENT]</b> key and zero calibration is completed. | <br>Measurement display     |
| (4)   |               | Close the stop valve.   |  |
| To cancel zero calibration, press the <b>[ESC]</b> key. |               |   |  |

## 9. RANGE SELECTION

---

- (1) Turn OFF the power supply to this instrument.
- (2) Open the door by removing 4 screws (M5).
- (3) Remove 3 mounting screws (M3) fastening the operation panel. Remove the operation panel.
- (4) Set the range selection switch at the rear of the operation panel at range position.
- (5) Return the operation panel to the original status.

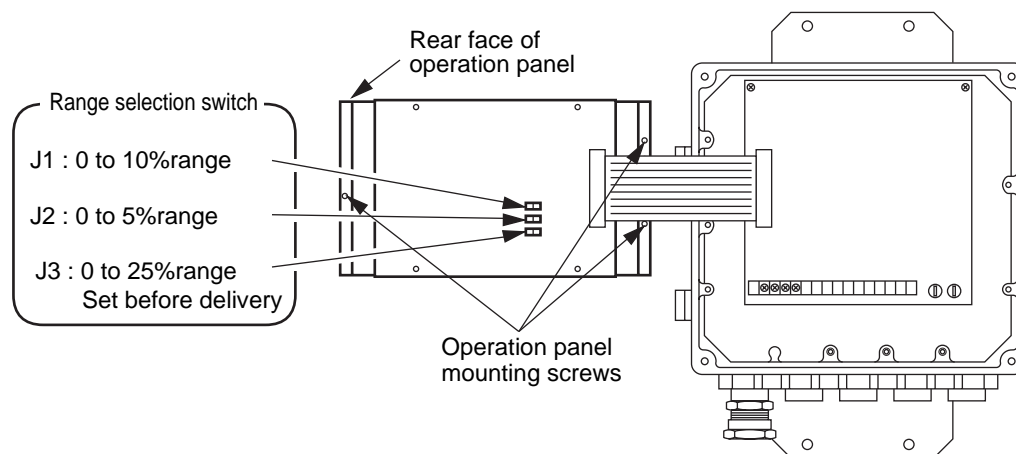

**\* Set the range selector while paying attention to the flat cable.**

# 10. ADJUSTMENT

## 10.1 Zirconia input signal adjustment

### Description

- This is used to adjust zero/span input of zirconia sensor signal.
- This adjustment should be made when required accuracy cannot be obtained after calibration.  
In general, do not perform the above operation because it is based on the factory adjustment mode.

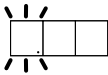
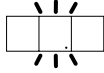
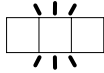

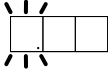
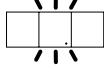
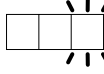
| Order   | Operation (example)     |  | How to adjust zero input  |  |
|---|-------------------------|--|---|--|
|   | Key operation           | Description  | Displayed message   |  |
| (1)   |                         | Apply a voltage of $0 \pm 0.01\text{mV}$ to external terminals of 3(+) and 4(-).   |   |  |
| (2)   | <b>ENT</b> + <b>ESC</b> | Hold down the <b>ENT</b> key and <b>ESC</b> key simultaneously for more than 5 seconds, then the decimal point in the 1st digit begins to blink. |  |  |
| (3)   | <b>ENT</b>              | Press the <b>ENT</b> key, then the decimal point in the 2nd digit begins to blink.   |  |  |
| (4)   | <b>ZERO</b>             | Press the <b>ZERO</b> key to blink the number in the 2nd digit.  |  |  |
| (5)   | <b>ENT</b>              | After confirming that voltage is applied to the terminals, press the <b>ENT</b> key, and then zero input adjustment can be performed.            |   |  |
| To cancel adjustment, press the <b>ESC</b> key. |                         |  |   |  |

| Order   | Operation (example)     |  | How to adjust span input  |  |
|---|-------------------------|--|---|--|
|   | Key operation           | Description  | Displayed message   |  |
| (1)   |                         | Apply a voltage of $50 \pm 0.01\text{mV}$ to external terminals of 3(+) and 4(-).  |   |  |
| (2)   | <b>ENT</b> + <b>ESC</b> | Hold down the <b>ENT</b> key and <b>ESC</b> key simultaneously for more than 5 seconds, then the decimal point in the 1st digit begins to blink. |  |  |
| (3)   | <b>ENT</b>              | Press the <b>ENT</b> key, then the decimal point in the 2nd digit begins to blink.   |  |  |
| (4)   | <b>SPAN</b>             | Press the <b>SPAN</b> key to blink the number in the 3rd digit.  |  |  |
| (5)   | <b>ENT</b>              | After confirming that voltage is applied to the terminals, press the <b>ENT</b> key, and then span input adjustment can be performed.            |   |  |
| To cancel adjustment, press the <b>ESC</b> key. |                         |  |   |  |

## 10.2 Temperature input adjustment

### Description

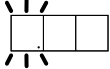
- This is used to adjust zero/span adjustment of the thermocouple.  
In general, do not perform the above operation because it is based on the factory adjustment mode.

| Order   | Operation (example)     | How to perform zero adjustment of thermocouple input   |   |
|---|-------------------------|--|---|
|   | Key operation           | Description  | Displayed message   |
| (1)   |                         | Apply a voltage confirming to 700°C to external terminals, 1(+) and 2(-).  |   |
| (2)   | <b>ENT</b> + <b>ESC</b> | Hold down the <b>ENT</b> key and <b>ESC</b> key simultaneously for more than 5 seconds, then the decimal point in the 1st digit begins to blink. |  |
| (3)   | <b>ZERO</b>             | Press the <b>ZERO</b> key, 2nd digit blinks in 700 display.  |  |
| (4)   | <b>ENT</b>              | After confirming that voltage is applied to the terminals, press the <b>ENT</b> key, and then zero adjustment can be performed.                  |   |
| To cancel adjustment, press the <b>ESC</b> key. |                         |  |   |

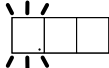
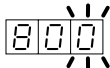
| Order   | Operation (example)     | How to perform span adjustment of thermocouple input   |   |
|---|-------------------------|--|---|
|   | Key operation           | Description  | Displayed message   |
| (1)   |                         | Apply a voltage confirming to 800°C to external terminals, 1(+) and 2(-).  |   |
| (2)   | <b>ENT</b> + <b>ESC</b> | Hold down the <b>ENT</b> key and <b>ESC</b> key simultaneously for more than 5 seconds, then the decimal point in the 1st digit begins to blink. |  |
| (3)   | <b>SPAN</b>             | Press the <b>SPAN</b> key, 3rd digit blinks in 800 display.  |  |
| (4)   | <b>ENT</b>              | After confirming that voltage is applied to the terminals, press the <b>ENT</b> key, and then span adjustment can be performed.                  |   |
| To cancel adjustment, press the <b>ESC</b> key. |                         |  |   |

### 10.3 Current output adjustment

**Description**

- This adjustment should be made when required accuracy can not be obtained after calibration. This is adjusted prior to delivery, so no further adjustment is required for normal operation.
- Adjust current by connecting an ammeter and a load resistor of 250Ω to external terminals 5(+) and 6(-).

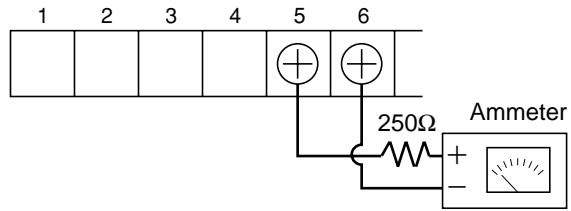

| Order  | Operation (example)                     | How to perform zero adjustment of current output  |                   |
|--|---|---|-------------------|
|  | Key operation                           | Description   | Displayed message |
| (1)  | <b>ENT</b>                              | Hold down the <b>ENT</b> key for more than 5 seconds, then the decimal point in the 3rd digit begins to blink.                                |                   |
| (2)  | <b>ZERO</b> + <b>ESC</b>                | Press the <b>ZERO</b> key and <b>ESC</b> key simultaneously, and zero adjustment mode (000 display) is displayed.                             |                   |
| (3)  | <b>SPAN</b> or <b>SPAN</b> + <b>ESC</b> | Press the <b>SPAN</b> key (increase) or press <b>SPAN</b> key + <b>ESC</b> key simultaneously (decrease) so that the ammeter may read 4mA DC. |                   |
| (4)  | <b>ENT</b>                              | When the ammeter reads 4±0.05mA, press the <b>ENT</b> key. Zero adjustment is performed.  |                   |
| To cancel zero adjustment, press the <b>ESC</b> key. |   |   |                   |

| Order  | Operation (example)                     | How to perform span adjustment of current output   |                   |
|--|---|--|-------------------|
|  | Key operation                           | Description  | Displayed message |
| (1)  | <b>ENT</b>                              | Hold down the <b>ENT</b> key for more than 5 seconds, then the decimal point in the 3rd digit begins to blink.                                 |                   |
| (2)  | <b>SPAN</b> + <b>ESC</b>                | Press the <b>SPAN</b> key and <b>ESC</b> key simultaneously, and span adjustment mode (100 display) is displayed.                              |                   |
| (3)  | <b>ZERO</b> or <b>ZERO</b> + <b>ESC</b> | Press the <b>ZERO</b> key (increase) or press <b>ZERO</b> key + <b>ESC</b> key simultaneously (decrease) so that the ammeter may read 20mA DC. |                   |
| (4)  | <b>ENT</b>                              | When the ammeter reads 20±0.05mA, press the <b>ENT</b> key. Span adjustment is performed.  |                   |
| To cancel span adjustment, press the <b>ESC</b> key. |   |  |                   |

## 10.4 Setting of detector control temperature

### Description

- Setting of control temperature is required according to types of the detector to be connected.

Type of detector and control temperature

ZFK2 (general use type) ..... Set to 800°C

ZFK5 (corrosion-proof type) ..... Set to 750°C

In general, do not perform the above operation because it is based on the factory adjustment mode.

When the detector needs to be replaced with any type other than above, it becomes necessary to change the set value.

| Order   | Operation (example)            | Setting to 750°C (ZFK5)   |                   |
|---|--------------------------------|---|-------------------|
|   | Key operation                  | Description   | Displayed message |
| (1)   | <b>ENT</b> + <b>ESC</b>        | Press the <b>ENT</b> key and <b>ESC</b> key at the same time for more than 5 seconds, and the decimal point in the 1st digit begins to blink.             |                   |
| (2)   | <b>ZERO</b>                    | When the <b>ZERO</b> key is pressed, the detector is set in the temperature control mode with the figure 700 displayed and the 2nd digit begins to blink. |                   |
| (3)   | <b>SPAN</b>                    | Next, press the <b>SPAN</b> key. The figure "7" in the 1st digit begins to blink.   |                   |
| (4)   | <b>ZERO</b>                    | Then, press the <b>ZERO</b> key. The figure "7" blinking in the 1st digit disappears and the 2nd digit begins to blink.                                   |                   |
| (5)   | <b>ENT</b><br>(or <b>ESC</b> ) | Press the <b>ENT</b> key (or <b>ESC</b> key), and the control temperature is set to 750°C when the display returns to the measurement mode.               |                   |
| To cancel the above operation, press the <b>ESC</b> key.<br>* Do not press the <b>ESC</b> key under the condition of (2). |                                |   |                   |

| Order   | Operation (example)            | Setting to 800°C (ZFK2)   |                   |
|---|--------------------------------|---|-------------------|
|   | Key operation                  | Description   | Displayed message |
| (1)   | <b>ENT</b> + <b>ESC</b>        | Press the <b>ENT</b> key and <b>ESC</b> key at the same time for more than 5 seconds, and the decimal point in the 1st digit begins to blink.             |                   |
| (2)   | <b>SPAN</b>                    | When the <b>SPAN</b> key is pressed, the detector is set in the temperature control mode with the figure 800 displayed and the 2nd digit begins to blink. |                   |
| (3)   | <b>ZERO</b>                    | Next, press the <b>ZERO</b> key. The figure "8" in the 1st digit begins to blink.   |                   |
| (4)   | <b>SPAN</b>                    | Then, press the <b>SPAN</b> key. The figure "8" blinking in the 1st digit disappears and the 3rd digit begins to blink.                                   |                   |
| (5)   | <b>ENT</b><br>(or <b>ESC</b> ) | Press the <b>ENT</b> key (or <b>ESC</b> key), and the control temperature is set to 800°C when the display returns to the measurement mode.               |                   |
| To cancel the above operation, press the <b>ESC</b> key.<br>* Do not press the <b>ESC</b> key under the condition of (2). |                                |   |                   |

## 10.5 Selection of alarm contact output

### Description

- Select the converter alarm contact output.
- Select the contact output from the 5th digit of the converter code symbols.







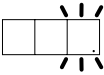

The 5th digit of code symbol:

B ..... Normal Open contact is selected.

C ..... Normal Close contact is selected.

For details of alarm contact output, refer to Item 6.4 Check on alarm data (Page 8).

In general, do not perform the above operation because it is based on the factory adjustment mode.

| Order  | Operation (example)     |  | Selection of alarm contact output   |  |
|--|-------------------------|--|---|--|
|  | Key operation           | Description  | Displayed message   |  |
| (1)  | <b>ENT</b>              | When the <b>ENT</b> key is pressed for more than 5 seconds, the decimal point in the 3rd digit begins to blink.  |                            |  |
| (2)  | <b>ENT</b> + <b>ESC</b> | Press the <b>ENT</b> key and <b>ESC</b> key at the same time to display the setting of the present contact output.<br><br> Normal Open contact<br> Normal Close contact | <br>Normal Open contact    |  |
| (3)  | <b>ZERO</b>             | By pressing the <b>ZERO</b> key,  and  are selected alternately.   | <br>Normal Close contact |  |
| (4)  | <b>ENT</b>              | By pressing the <b>ENT</b> key, the setting is finished when the display returns to the measurement mode.  | <br>Measurement display  |  |
| To cancel the above operation, press the <b>ESC</b> key. |                         |  |   |  |

# 11. MAINTENANCE AND CHECK

## 11.1 Check

In order to keep the instrumentation operating in good condition, perform the following periodical maintenance and check.

Perform maintenance and check once every year or 2, or at time of furnace check.

|                  | Check items   | Measures   |
|------------------|---|--|
| Daily check      | Zero, span calibration                                    | Calibrate once every week (Refer to Chapter 8 “Calibration”)   |
|                  | Deterioration of packings and O-rings                     | If deteriorated, replace with new ones.  |
|                  | Check for loose cable ground                              | Retighten or replace the packing.  |
|                  | Check the remain pressure in the calibration gas cylinder | Check the amount using primary pressure.   |
| Periodical check | Clogging or corrosion of flow guide tubes                 | Remove the flow guide tube from the furnace wall, remove the detector and wash the flow guide tube with water. |
|                  | Contamination of ceramic filter in detector               | Clean or renew the ceramic filter in detector.   |
|                  | Check of measured value current output                    | Check the current output of measured value (referring to Item 10.3 “Current output adjustment”).               |

## 11.2 Fuse replacement

When a fuse blows, turn off the power switch, and replace the fuse after investigating the cause.

Open the front cover of the sensor.

Two fuses are located at lower right.

**The right fuse is for protection of the sensor circuit and the left one is for protection of the heater. Take care that these fuses are different each other in the rated current.**

For replacement, use a vessel style (flat-blade) screwdriver or coin.

Push down the cap on the fuse holder and rotate about 1/4 turn counterclockwise until the cap is removed from the fuse holder.

Then, replace the fuse with a new one.

Next, push in the cap and rotate about 1/4 turn clockwise until it is fitted to the fuse holder.

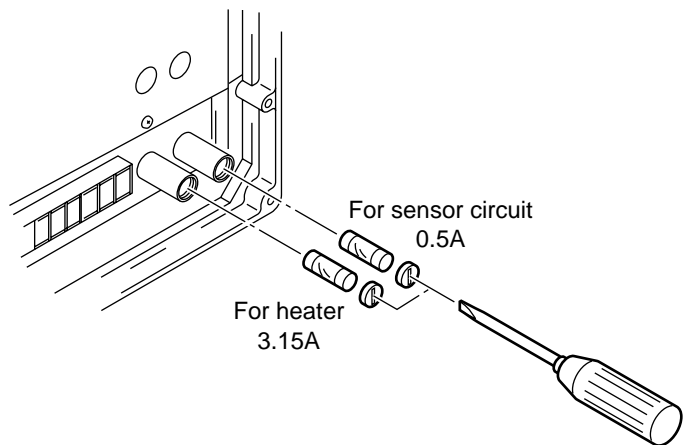

Fuse unit specifications (Reference)

|             | Specification                          |
|-------------|--|
| For circuit | ø5.2 × 20mm 250V 0.5A time-delay type  |
| For heater  | ø5.2 × 20mm 250V 3.15A time-delay type |

## 11.3 Troubleshooting

| Symptoms   | Probable causes  | Checking methods   | Remedy  |
|--|--|--|---|
| No display   | Converter fuse blown out   | Check the fuse and supply voltage specification.   | Replace fuse<br>Check power supply voltage          |
| Indication does not change or slow response                | Filter and/or flow guide tube clogged  | Visual check of filter and flow guide tube for contamination or clogging.<br>Check for loosen and gas leaks at piping connections and mounting place of detector.                | Clean or replace filter<br>Tighten pipe connections |
|  | Sensor element deterioration   | Change over between zero and span gas and check if 5 minutes or longer is needed for 90% response.   | Replace sensor element                              |
|  | Decrease in flow velocity of exhaust gas   | Check response to process gas after shutting down calibration gas.<br>Move the direction (mounting position) of "arrow" of the flow guide slightly.                              | Increase process gas flow into the flow guide tube  |
| Indication too high or too low                             | Loose flange and its surroundings  | Check for gas leaks in detector and mounting part of flow guide tube flange.   | Tighten mounting screws<br>Replace O-ring           |
|  | Deteriorated O-rings   | Check for leaks from the outside.  | Seal  |
|  | Senor malfunction  | Check for gas leaks at calibration gas inlet.<br>Check if sensor output (mV) is higher or lower when flowing zero gas.<br>(Refer to Item 6.5 "Oxygen detector standard output.") | Tighten connectors<br>Replace sensor element        |
|  | Break of wiring  | Ohmic check of wiring  | Replace   |
|  | Wrong wiring   | Wiring check   | Correct wiring                                      |
|  | Lower power supply voltage   | Check of supply voltage specification  | Check supply voltage                                |
|  | Break of thermocouples   | Ohmic check and abnormal temperature check   | Replace sensor element                              |
|  | Blown heater fuse  | Ohmic check of fuse  | Replace fuse  |
| Break in sensor heater                                     | Check heater resistance<br>50 to 55Ω for 100V, 200 to 250Ω for 220V<br>(Excluding wiring resistance) | Replace sensor element   |   |
| Indication difference between dry and wet base measurement | Oxygen concentration is higher in dry base.  | Normal   |   |

## 12. APPENDIX

---

### 12.1 Specification

#### (1) General

- Measured gas : Oxygen contained in non-combustible gas
- Measuring method : Direct inserting type zirconia system
- Measuring range : 0 to 5, 10 and 25 vol% (selectable by selector in converter)
- Repeatability :  $\pm 1\%$  FS
- Linearity :  $\pm 2.0\%$  FS
- Response speed : Within 7 sec for 90% response (from calibration gas inlet)
- Power supply : Detector; 100 to 115 V AC, 50/60 Hz or 200 to 240 V AC, 50/60 Hz  
Converter; 100 to 240 V AC, 50/60 Hz
- Power consumption : Approx. 15 + 50 VA (in steady state)  
Approx. 15 + 200 VA (at start)
- Warmup-time : 15 minutes approx.

#### (2) Oxygen detector (type ZFK2, 5)

- Measuring instrument : General use ZFK2  
For corrosive gas ZFK5
- Measured gas temperature : -20 to 600°C for flow guide tube type (for general use, corrosive gas)
- Measured gas pressure : -3 to +3kPa
- Flow guide tube : Without blow-down nozzle  
Flange : JIS-5K 65A FF  
Insertion length (according to specification) : 0.3, 0.5, 0.75, 1.0m
- Ambient temperature : -20 to 60°C (for cable section)  
125°C or less at the sensor flange surface with power ON
- Structure : Dust/rain-proof structure (conforming with IEC standard IP55)  
Protection cover necessary in cold climate (available when specified)
- Filter : Alumina (filtration accuracy 50 $\mu$ m) and quartz paper
- Material of gas-contacting : General use detector : Zirconia SCS14 (equivalent to SUS316), platinum, SUS304 parts  
For corrosive gas detector: Zirconia, titanium, platinum, SUS316
- Calibration gas inlet :  $\phi 6$  mm tube joint or  $\phi 1/4$ -inch tube joint (as specified)
- Standard gas inlet : Rc 1/8 joint port or NPT 1/8 joint (as specified)  
Used when standard oxygen gas concentration changes, for example.
- Detector mounting : Horizontal  $\pm 45^\circ$ , surrounding air should be clean.
- Outline dimensions : (L  $\times$  max. dia.) 210  $\times$  100mm (sensor)
- Mass : Sensor, approx. 1.6kg  
Flow guide tube of 1m (general use type), approx. 5kg
- Finish color : Silver and SUS metallic color
- Calibration gas flow : 1 to 1.5 L/min

---

### (3) Oxygen converter (type ZRY)

- Measuring range : 0 to 5, 10 and 25 vol% (selectable by selector in converter)
- Repeatability :  $\pm 1\%$  FS
- Linearity :  $\pm 2\%$  FS
- Display : Oxygen gas concentration with 3-digit LED
- Oxygen concentration : 4 to 20 mA DC (allowable load resistance 500  $\Omega$ max.)  
output signal : Input-output isolation, linear characteristic versus oxygen concentration
- Alarm contact output : Contact specifications; 1 point, 250 V AC, 2 A  
Contact function; Contact “closes” or “opens” at error as specified.
- Self-diagnosis function : Detector temperature error, zero calibration error, span calibration error diagnosable
- Calibration method : Manual calibration by key operation
- Calibration gas inlet : 3-way valve (for zero and span calibration gases)  
valve (option)
- Calibration gas : Recommended concentration of calibration gas  
Zero gas; 0.25 to 2.0% O<sub>2</sub>  
Span gas; 20.6 to 21.0 % O<sub>2</sub> (oxygen concentration in atmospheric air)
- Ambient temperature : -10 to +50°C
- Ambient humidity : 90% RH or less
- Power supply : 100 to 240 V AC, 50/60 Hz
- Structure : Dust/rain-proof structure (conforming with IEC standard IP65)
- Casing material : Die-cast aluminum
- External dimensions : 220 × 230 × 95 mm  
(H × W × D)
- Mass : Approx. 4.5 kg (excluding cable and detector)
- Finish color : Munsell 6PB 3.5/10.5 (blue) ..... cover  
Silver ..... casing
- Mounting method : Mounting on panel surface

### (4) Exclusive cable (type ZRZP)

- Cable : 4-core shielded (for oxygen gas signal, R thermocouple signal) and 2-core (for power supply)
- Conduit : Flexible type (cable built in)
- Length : As specified by PILC code.

### (5) Based-on standards

- Product safety : EN61010-1;2001
- ENC : EN61326-1; 1997, A1: 1998, A2: 2001

## 12.2 Designation of type (PILC code table)

### (1) Type of detector

| 1 | 2 | 3 | 4 | 5 | 6 | 7 | 8 | 9 | 10 | 11 | 12 | 13 | Digits | Description                              |
|---|---|---|---|---|---|---|---|---|----|----|----|----|--------|--|
| Z | F | K | R | 4 |   |   |   |   |    |    |    |    |        |  |
|   |   |   |   | 2 |   |   |   |   |    |    |    |    |        | Application (4th digit)                  |
|   |   |   |   | 5 |   |   |   |   |    |    |    |    |        | General use                              |
|   |   |   |   |   |   |   |   |   |    |    |    |    |        | For corrosive gas                        |
|   |   |   |   |   |   |   |   |   |    |    |    |    |        | Type (5th digit)                         |
|   |   |   |   |   |   |   |   |   |    |    |    |    |        | Standard (R thermocouple)                |
|   |   |   |   |   |   |   |   |   |    |    |    |    |        | Calibration gas inlet (6th digit)        |
|   |   |   |   |   |   |   |   |   |    |    |    |    |        | Polyproprene joint for ø6 tube           |
|   |   |   |   |   |   |   |   |   |    |    |    |    |        | Brass joint for ø1/4 in. tube            |
|   |   |   |   |   |   |   |   |   |    |    |    |    |        | Power supply (7th digit)                 |
|   |   |   |   |   |   |   |   |   |    |    |    |    |        | 100/115V AC 50/60Hz                      |
|   |   |   |   |   |   |   |   |   |    |    |    |    |        | 200/220V AC 50/60Hz                      |
|   |   |   |   |   |   |   |   |   |    |    |    |    |        | 230V AC 50/60Hz (CE-marking approved)    |
|   |   |   |   |   |   |   |   |   |    |    |    |    |        | Flow guide tube (9th, 10th, 11th digits) |
|   |   |   |   |   |   |   |   |   |    |    |    |    |        | (Flange material) (Type) (Length)        |
|   |   |   |   |   |   |   |   |   |    |    |    |    |        | 0Y0 None                                 |
|   |   |   |   |   |   |   |   |   |    |    |    |    |        | 5A3 SUS304 General use 300mm             |
|   |   |   |   |   |   |   |   |   |    |    |    |    |        | 5A5 SUS304 General use 500mm             |
|   |   |   |   |   |   |   |   |   |    |    |    |    |        | 5A7 SUS304 General use 750mm             |
|   |   |   |   |   |   |   |   |   |    |    |    |    |        | 5A1 SUS304 General use 1000mm            |
|   |   |   |   |   |   |   |   |   |    |    |    |    |        | 5B3 SUS316 For corrosive gas 300mm       |
|   |   |   |   |   |   |   |   |   |    |    |    |    |        | 5B5 SUS316 For corrosive gas 500mm       |
|   |   |   |   |   |   |   |   |   |    |    |    |    |        | 5B7 SUS316 For corrosive gas 750mm       |
|   |   |   |   |   |   |   |   |   |    |    |    |    |        | 5B1 SUS316 For corrosive gas 1000mm      |
|   |   |   |   |   |   |   |   |   |    |    |    |    |        | Protection cover (12th digit)            |
|   |   |   |   |   |   |   |   |   |    |    |    |    |        | Y Without                                |
|   |   |   |   |   |   |   |   |   |    |    |    |    |        | A With                                   |
|   |   |   |   |   |   |   |   |   |    |    |    |    |        | Reference air inlet (13th digit)         |
|   |   |   |   |   |   |   |   |   |    |    |    |    |        | Y None                                   |
|   |   |   |   |   |   |   |   |   |    |    |    |    |        | A Rc 1/8                                 |
|   |   |   |   |   |   |   |   |   |    |    |    |    |        | B NPT 1/8                                |

### (2) Type of replacement sensor

| 1 | 2 | 3 | 4 | 5 | 6 | 7 | 8 | 9 | 10 | 11 | 12 | 13 | Digits | Description                           |
|---|---|---|---|---|---|---|---|---|----|----|----|----|--------|---------------------------------------|
| Z | F | K | R | 4 | 0 | Y | 0 | Y | Y  |    |    |    |        |                                       |
|   |   |   |   | 2 |   |   |   |   |    |    |    |    |        | Application (4 digit)                 |
|   |   |   |   | 5 |   |   |   |   |    |    |    |    |        | General use                           |
|   |   |   |   |   |   |   |   |   |    |    |    |    |        | For corrosive gas                     |
|   |   |   |   |   |   |   |   |   |    |    |    |    |        | Type (5th digit)                      |
|   |   |   |   |   |   |   |   |   |    |    |    |    |        | Standard                              |
|   |   |   |   |   |   |   |   |   |    |    |    |    |        | Calibration gas inlet (6th digit)     |
|   |   |   |   |   |   |   |   |   |    |    |    |    |        | Polyproprene joint for ø6 tube        |
|   |   |   |   |   |   |   |   |   |    |    |    |    |        | Brass joint for ø1/4 in. tube         |
|   |   |   |   |   |   |   |   |   |    |    |    |    |        | Power supply (7th digit)              |
|   |   |   |   |   |   |   |   |   |    |    |    |    |        | 100/115V AC 50/60Hz                   |
|   |   |   |   |   |   |   |   |   |    |    |    |    |        | 200/220V AC 50/60Hz                   |
|   |   |   |   |   |   |   |   |   |    |    |    |    |        | 230V AC 50/60Hz (CE-marking approved) |

### (3) Type of converter

| 1 | 2 | 3 | 4 | 5 | 6 | 7 | 8 | 9 | 10 | 11 | 12 | Description  |
|---|---|---|---|---|---|---|---|---|----|----|----|--|
| Z | R | Y | 1 |   |   |   |   | 1 | R  |    | 0  | Alarm contact output, measurement output (5th digit) |
|   |   |   |   |   | B |   |   |   |    |    |    | "Close" at alarm, 4 to 20mA DC                       |
|   |   |   |   |   | C |   |   |   |    |    |    | "Open" at alarm, 4 to 20mA DC                        |
|   |   |   |   |   |   | Y |   |   |    |    |    | Option (6th digit)                                   |
|   |   |   |   |   |   | D |   |   |    |    |    | Without selector cock                                |
|   |   |   |   |   |   |   |   |   |    |    |    | With selector cock                                   |
|   |   |   |   |   |   |   | 1 |   |    |    |    | Power supply (7th digit)                             |
|   |   |   |   |   |   |   |   |   |    |    |    | 100 to 240V AC 50/60Hz                               |
|   |   |   |   |   |   |   |   | 1 |    |    |    | Mounting method (9th digit)                          |
|   |   |   |   |   |   |   |   |   |    |    |    | Mounting on panel surface                            |
|   |   |   |   |   |   |   |   |   | R  |    |    | Thermocouple input (10th digit)                      |
|   |   |   |   |   |   |   |   |   |    |    |    | Thermocouple R                                       |
|   |   |   |   |   |   |   |   |   |    |    |    | Instruction manual (11th digit)                      |
|   |   |   |   |   |   |   |   |   |    | Y  |    | None   |
|   |   |   |   |   |   |   |   |   |    | J  |    | Japanese-language manual                             |
|   |   |   |   |   |   |   |   |   |    | E  |    | English-language manual                              |

### (4) Type of exclusive cable connecting converter to sensor

| 1 | 2 | 3 | 4 | 5 | 6  | 7 | 8 | 9 | Description                              |
|---|---|---|---|---|----|---|---|---|--|
| Z | R | Z | P | R |    |   |   | 1 | Specification                            |
|   |   |   |   |   |    |   |   |   | For ZRY                                  |
|   |   |   |   |   |    |   |   |   | Type                                     |
|   |   |   |   |   |    |   |   |   | For thermocouple R                       |
|   |   |   |   |   |    |   |   |   | Flexible conduit length (6th, 7th digit) |
|   |   |   |   |   |    |   |   |   | Cable length                             |
|   |   |   |   |   | YA |   |   |   | Without 6 m                              |
|   |   |   |   |   | YB |   |   |   | Without 10m                              |
|   |   |   |   |   | YC |   |   |   | Without 15m                              |
|   |   |   |   |   | YD |   |   |   | Without 20m                              |
|   |   |   |   |   | YE |   |   |   | Without 30m                              |
|   |   |   |   |   | YF |   |   |   | Without 40m                              |
|   |   |   |   |   | YG |   |   |   | Without 50m                              |
|   |   |   |   |   | YH |   |   |   | Without 60m                              |
|   |   |   |   |   | YJ |   |   |   | Without 70m                              |
|   |   |   |   |   | YK |   |   |   | Without 80m                              |
|   |   |   |   |   | YL |   |   |   | Without 90m                              |
|   |   |   |   |   | YM |   |   |   | Without 100m                             |
|   |   |   |   |   | AA |   |   |   | 6 m 6 m                                  |
|   |   |   |   |   | BB |   |   |   | 10m 10m                                  |
|   |   |   |   |   | CC |   |   |   | 15m 15m                                  |
|   |   |   |   |   | DD |   |   |   | 20m 20m                                  |
|   |   |   |   |   |    |   |   |   | Termination (9th digit)                  |
|   |   |   |   |   |    |   |   | 0 | Without                                  |
|   |   |   |   |   |    |   |   | 1 | One end (sensor side)                    |
|   |   |   |   |   |    |   |   | 2 | Both ends                                |

**Note:** Used for connection between the detector and converter.  
Conduit is a rainproof and flexible type.

## 12.3 Outline diagram (unit:mm)

### Converter (ZRY)

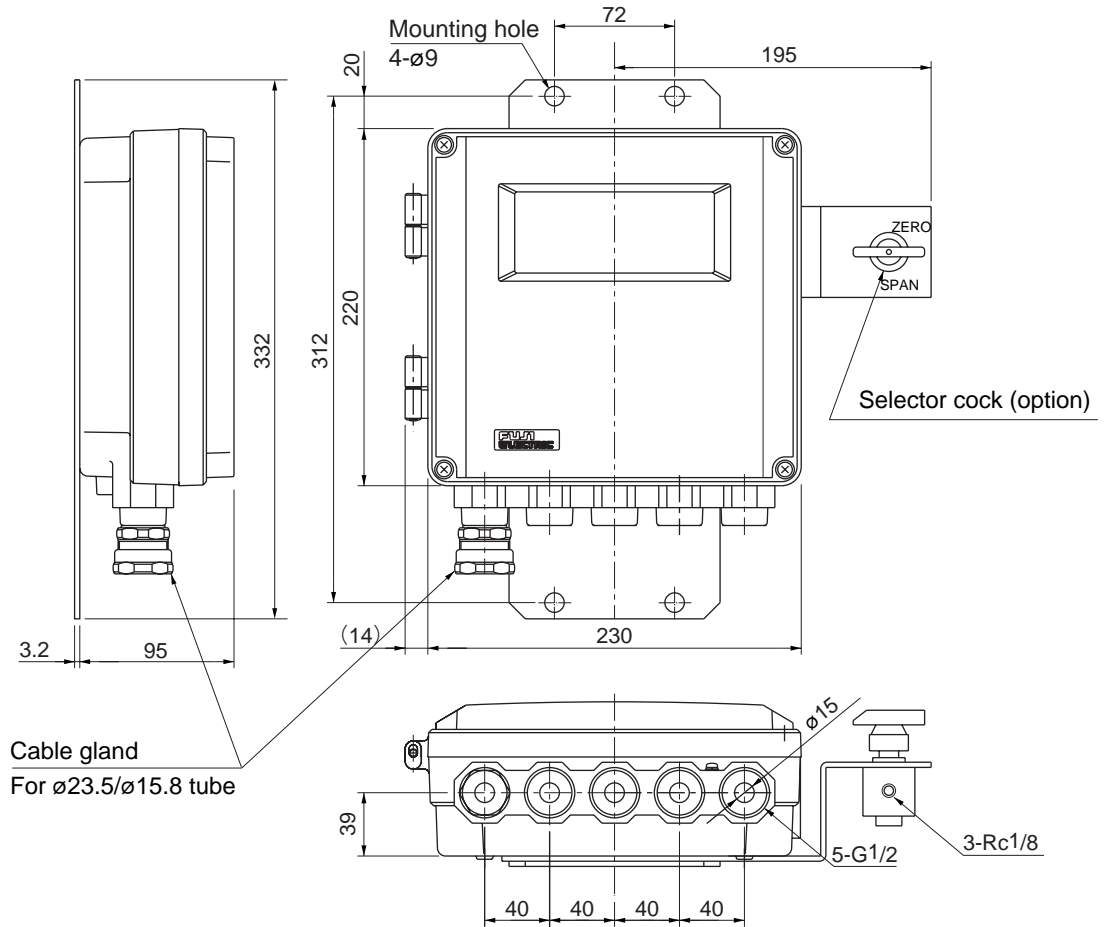

### Connection diagram

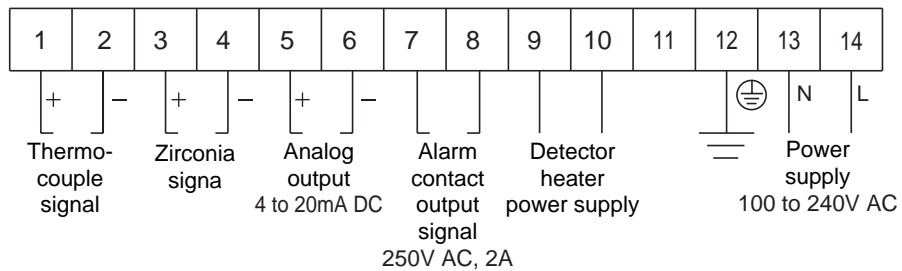

State of alarm contact output (between terminals Nos. 7 and 8)

| 5th digit of<br>PILC code | Power OFF | Power ON,<br>normal | Power ON,<br>alarm |
|---------------------------|-----------|---------------------|--------------------|
| B                         | Open      | Open                | Closed             |
| C                         | Open      | Closed              | Open               |

---

## **Fuji Electric Systems Co., Ltd.**

### **Head Office**

Gate City Ohsaki, East Tower, 11-2, Osaki 1-chome,  
Shinagawa-ku, Tokyo 141-0032, Japan  
<http://www.fesys.co.jp/eng>

### **Instrumentation Div.**

#### **International Sales Dept.**

No.1, Fuji-machi, Hino-city, Tokyo 191-8502, Japan  
Phone: 81-42-585-6201, 6202 Fax: 81-42-585-6187  
<http://www.fic-net.jp/eng>

---