



Instruction Manual

THERMAL CONDUCTIVITY GAS ANALYZER <THERMOMAT>

TYPE: ZAF



PREFACE

We are grateful for your purchase of Fuji Electric's Thermal Conductivity Gas Analyzer (Type:ZAF3).

- First read this instruction manual carefully until an adequate understanding is acquired, and then proceed to installation, operation and maintenance of the gas analyzer. Wrong handling may cause an accident or injury.
- The specifications of this gas analyzer are subject to change without prior notice for further product improvement.
- Modification of this gas analyzer is strictly prohibited unless a written approval is obtained from the manufacturer. Fuji Electric will not bear any responsibility for a trouble caused by such a modification.
- This instruction manual shall be stored by the person who actually uses the gas analyzer.
- After reading the manual, be sure to store it at a place easier to access.
- This instruction manual should be delivered to the end user without fail.

Manufacturer: Fuji Electric Instrumentation Co., Ltd.
Type: Described in Fuji Electric's company nameplate on main frame
Date of manufacture: Described in Fuji Electric's company nameplate on main frame
Product nationality: Japan

Delivered Items

Name	Quantity
Analyzer main frame	1 unit
Panel mounting brackets	1 set
Instruction manual	1 copy

Request

- It is prohibited to transfer part or all of this manual without Fuji Electric's permission.
- Description in this manual is subject to change without prior notice for further improvement.



© Fuji Electric Systems Co., Ltd. 2003



Issued in October, 2003

CAUTION ON SAFETY

First of all, read this “Caution on safety” carefully, and then use the analyzer in the correct way.

- The cautionary descriptions listed here contain important information about safety, so they should always be observed. Those safety precautions are ranked in 2 levels; DANGER and CAUTION.

 DANGER	Wrong handling may cause a dangerous situation, in which there is a risk of death or heavy injury.
 CAUTION	Wrong handling may invite a dangerous situation, in which there is a possibility of medium-level trouble or slight injury or only physical damage is predictable.

Caution on installation and transport of gas analyzer	
 DANGER	<ul style="list-style-type: none">• This unit is not explosion-proof type. Do not use it in a place with explosive gases to prevent explosion, fire or other serious accidents.
 CAUTION	<ul style="list-style-type: none">• This unit should be installed in a place which conforms to the conditions noted in the instruction manual. Otherwise, it may cause electric shocks, fire or malfunction of the unit.• During installation work, care should be taken to keep the unit free from entry of cable chips or other foreign objects. Otherwise, it may cause fire, trouble or malfunction of the unit.• For lifting the gas analyzer, be sure to wear protective gloves. Bare hands may invite an injury.• Before transport, fix the casing so that it will not open. Otherwise, the casing may be separated and fall to cause an injury.

Caution on wiring



- The unit must be earthed as specified. Otherwise, it may cause electric shocks, malfunction, etc.
- Be sure to use a power supply of correct rating. Connection of power supply of incorrect rating may cause fire.
- Wiring work must be performed with the main power set to OFF to prevent electric shocks.
- Use wiring materials that match the rating of the unit. Use of wiring materials out of rating may cause fire.

Caution on piping



In piping, the following precautions should be observed. Wrong piping may cause gas leakage. If the leaking gas contains a toxic component, there is a risk of serious accident being induced. Also, if combustible gas is contained, there is a danger of explosion, fire or the like occurring.

- Connect pipes correctly referring to the instruction manual.
- Exhaust should be led outdoors so that it will not remain in the locker and installation room.
- Exhaust from the analyzer should be relieved in the atmospheric air in order that an unnecessary pressure will not be applied to the analyzer. Otherwise, any pipe in the analyzer may be disconnected to cause gas leakage.

Caution on use



- Before using the standard gas such as calibration gas, read the manual for standard gas carefully to assure correct handling. Especially, dangerous gases such as CO gas requires extra caution, otherwise it may cause serious accident such as gas poisoning.



- Avoid continuous operation with the casing drawn out. Otherwise, the casing may fall to cause an injury.
- During operation, avoid opening the casing and touching the internal parts. Otherwise, you may suffer a burn or shock hazard.

Caution on maintenance and check



- When doors are open during maintenance or inspection, be sure to purge sufficiently the inside of the gas analyzer as well as the measuring gas line with nitrogen or air, in order to prevent poisoning, fire or explosion due to gas leaks.
- Before replacing the gas filter of the gas analyzer, turn OFF the pump power supply and close the calibration gas valve, in order to prevent poisoning, fire or explosion due to gas leaks.



- Before performing maintenance or inspection, turn OFF the power. Otherwise, touching electric parts may result in electric shock.
- Before working, take off a wrist watch, finger ring or the like metallic accessories. And never touch the instrument with a wet hand. Otherwise, you will have a shock hazard.
- If the fuse is blown, eliminate the cause, and then replace it with the one of the same capacity and type as before. Otherwise, shock hazard or fault may be caused.

Others



- If the cause of any fault cannot be determined despite reference to the instruction manual, be sure to contact your dealer or Fuji Electric's technician in charge of adjustment. If the instrument is disassembled carelessly, you may have a shock hazard or injury.
- Do not use a replacement part other than specified by the instrument maker. Otherwise, adequate performance will not be provided. Besides, an accident or fault may be caused.
- Replacement parts such as a maintenance part should be disposed of as incombustibles. For details, follow the local ordinance.

CONTENTS

PREFACE	i
CAUTION ON SAFETY	ii
1. OVERVIEW	1
2. NAME AND DESCRIPTION OF EACH PART	2
2.1 Description of each unit	2
2.2 Principle of operation	3
3. INSTALLATION	5
3.1 Selection of installation site	5
3.2 Mounting method	6
3.3 Piping	7
3.4 Sampling	9
3.5 Wiring method	11
4. OPERATION	15
4.1 Preparation for operation	15
4.2 Warm-up operation and regular operation	15
5. DESCRIPTION OF DISPLAY AND OPERATION PANEL	16
5.1 Name and description of operation panel	16
5.2 Overview of display and operation panel	17
5.3 Overview of display screen	18
5.4 General operation	20
6. SETTING AND CALIBRATION	21
6.1 Calibration setting	21
6.1.1 Setting of calibration concentration	21
6.1.2 Setting of calibration range	22
6.2 Alarm setting	24
6.2.1 Setting of alarm values	24
6.2.2 Hysteresis setting	27
6.3 Setting of auto calibration	28
6.3.1 Auto calibration	28
6.3.2 Forced stop of auto calibration	30
6.4 Changeover of range	31
6.5 Parameter setting	32
6.6 Maintenance mode	35
6.6.1 Sensor input value screen	36
6.6.2 Error log file	36
6.6.3 Password setting	37
6.6.4 Station No. setting	38
6.6.5 Contact output setting	39
6.6.6 Calibration history	41

6.7	Manual calibration	42
6.7.1	Zero calibration	42
6.7.2	Span calibration	43
7.	MAINTENANCE	44
7.1	Daily check	44
7.2	Daily check and maintenance procedures	44
8.	TROUBLESHOOTING	45
8.1	Error message	45
9.	SPECIFICATIONS	47
9.1	General specifications	47
9.2	Code symbols	50
9.3	Outline diagram	51

1. OVERVIEW

Thermal conductivity gas analyzers, which assure stable measurement with simple detector section structure, have long been used widely for processing and for the field use.

The thermal conductivity gas analyzer ZAF measures specific component in mixed gases through the use of characteristics that gases have different thermal conductivities.

The gas analyzer, whose operability has been improved and high accuracy and multiple functions have been achieved with the microprocessor installed and high accuracy large LCD adopted, is ideal for the management and control of production processes.

2. NAME AND DESCRIPTION OF EACH PART

2.1 Description of each unit

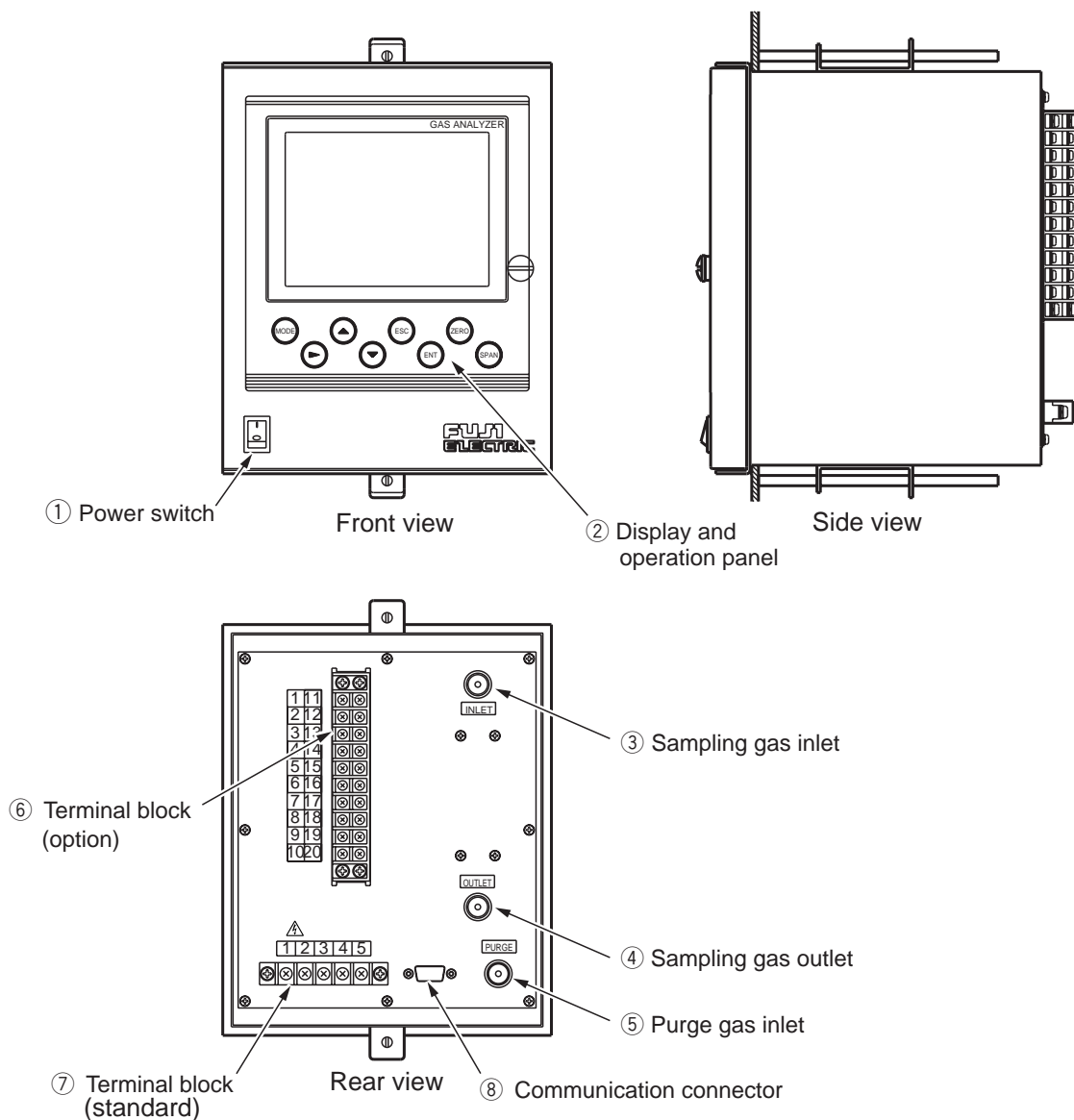

Name	Description
① Power switch	Turns ON/OFF this analyzer.
② Display/Operation panel	Liquid crystal display and keys for various operational settings are arranged.
③ Sampling gas inlet	Port for connecting the sample gas injection pipe.
④ Sampling gas outlet	Port for connecting the pipe for discharging the gas after analysis.
⑤ Purge gas inlet	Port for connecting the purge gas pipe.
⑥ Terminal block (option)	Contact input output and measured output terminals
⑦ Terminal block (standard)	Power terminal and measured output terminals
⑧ Connector for communication	RS-232C communication interface

2.2 Principle of Operation

Two platinum wires are stretched along center lines of two slots respectively formed through a metal block. The platinum wires are heated to approx. 100°C with a DC current (bridge current). The two slots form a sample chamber and a reference chamber respectively, and the platinum wires form a Wheatstone bridge in combination with two fixed resistors arranged outside the chambers. When thermal conductivity of sample gas changes, temperature of the platinum changes to vary its electrical resistance in the sample chamber, whereas temperature and resistance of the platinum wire do not change in the reference chamber in which thermal conductivity of a reference gas is kept always constant.

Therefore, the Wheatstone bridge generates a voltage signal depending on kinds and concentration of the sample gas.

The thermal conductivity gas analyzer is constructed as shown in Fig. 2-1.

Table 2-1 lists thermal conductivities of typical gas components, and Table 2-2 summarizes indicating deviations due to interfering components in measurements with the thermal conductivity gas analyzer.

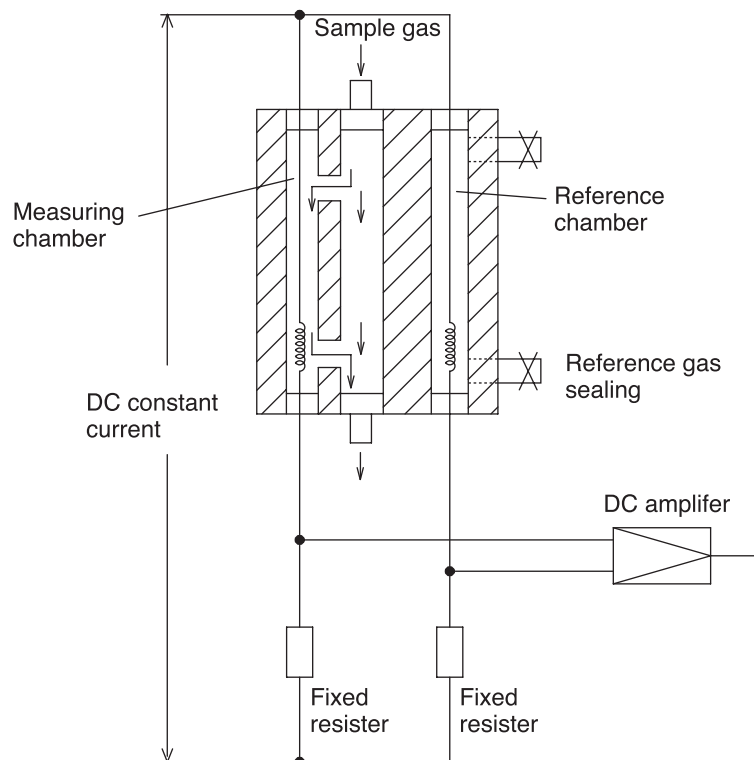

Fig.2-1 Structural View of Thermal Conductivity Gas Analyzer

**Table 2-1 Relative Thermal Conductivities of Typical Gas Components
(Specific Thermal Conductivities)**

The relative values mentioned above were determined taking thermal conductivity of air as 0.566×10^4 (cal/cm.sec.deg) = 100 (at 0°C).

Type of gas components	Relative value	Type of gas components	Relative value
Hydrogen H ₂	701	Ammonia NH ₃	90.7
Helium He	599	Acetylene C ₂ H ₂	77.7
Methane CH ₄	126	Argon Ar	68.5
Oxygen O ₂	101	Nitrous oxide N ₂ O	64
Nitrogen N ₂	100.3	Carbonic acid gas CO ₂	59
Nitrogen monoxide NO	100.2	Hydrogen sulfide H ₂ S	53.8
Air	100	Sulfur dioxide SO ₂	34.4
Carbon monoxide CO	96	Chlorine CN ₂	32.3

**Table 2-2 Indicating Deviation due to Interfering Components in
Thermal Conductivity Gas Analyzer**

Interfering component	Indicating Deviation due to 1% of interfering component (VOL %)			
	H ₂ indicator	CH ₄ indicator	Ar indicator	CO ₂ indicator
1% H ₂	—	+5.8	-6.5	-8.0
1% CH ₄	+0.17	—	-1.15	-1.38
1% SO ₂	-0.31	-1.8	+2.1	+2.5
1% Ar	-0.15	-0.87	—	+1.2
1% CO ₂	-0.125	-0.725	+0.83	—
1% O ₂	+0.019	+0.11	-0.125	-0.15
1.5°C Saturated H ₂ O	—	—	—	-0.56

Caution

Note 1. The indication errors mentioned above were obtained after adjusting the instrument by using sample gas + air as a balancing material.

Note 2. How to read the table

- (1) 1% of CO₂ causes an indication error of -0.125% on the H₂ indicator.
- (2) 1% of CH₄ produces an indication deviation of -1.38% on the CO₂ indicator.

3. INSTALLATION

DANGER

This unit is not explosion-proof type. Do not use it in a place with explosive gases to prevent explosion, fire or other serious accidents.

CAUTION

- This unit should be installed in a place which conforms to the conditions noted in the instruction manual. Otherwise, it may cause electric shocks, fire or malfunction of the unit.
- During installation work, care should be taken to keep the unit free from cable chips or other foreign objects. Otherwise, it may cause fire, trouble or malfunction of the unit.
- For lifting the gas analyzer, be sure to wear protective gloves. Bare hands may invite an injury.
- Before transport, fix the casing so that it will not open. Otherwise, the casing may be separated and fall to cause an injury.

3.1 Selection of installation site

To install the analyzer for optimum performance, select a location that meets the following conditions;

- (1) A place where the equipment does not receive direct sunshine, draft/rain or radiation from hot substances. If such a place cannot be found, a roof or cover should be prepared for protection.
- (2) A vibration-free place
- (3) A place which is clean around the analyzer.
- (4) Rated operation condition

Power supply : 100V to 240V AC 50/60 Hz

Power consumption : Approx. 50 VA

Ambient temperature : -5 to 45°C

Ambient humidity : 90% RH or less, no condensation

- (5) Storage conditions

Ambient temperature : -20 to 60°C

Ambient humidity : 95% RH or less, no condensation

3.2 Mounting method

Panel flush mounting

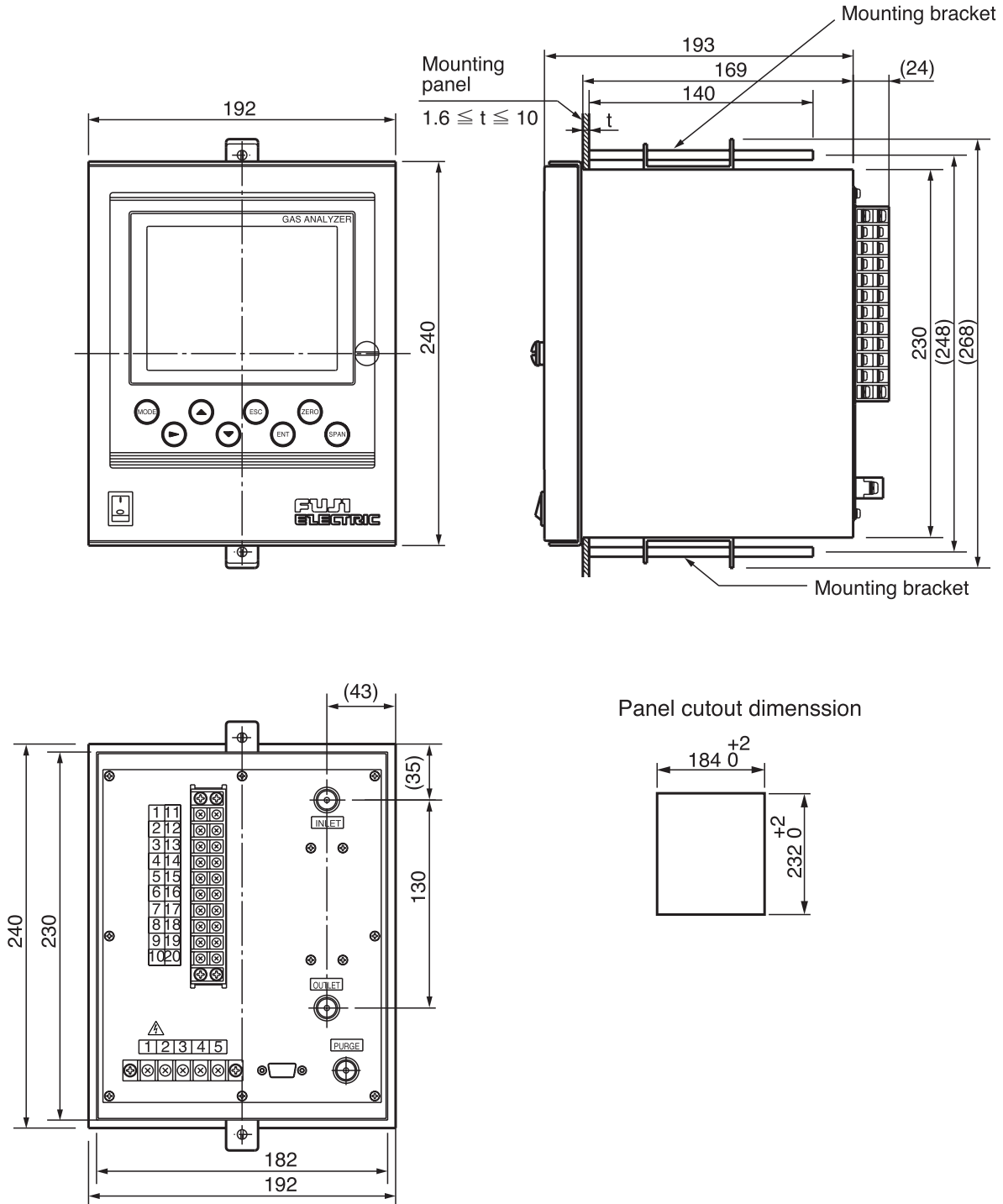

Note) Insert the analyzer into the panel cutout and fix the fittings on the analyzer from the rear panel. Secure it to the panel by screws.

3.3 Piping



DANGER

In piping, the following precautions should be observed. Wrong piping may cause gas leakage. If the leaking gas contains a toxic component, there is a risk of serious accident being induced. Also, if combustible gas is contained, there is a danger of explosion, fire or the like occurring.

- Connect pipes correctly referring to the instruction manual.
- Exhaust should be led outdoors so that it will not remain in the locker and installation room.
- Exhaust from the analyzer should be relieved in the atmospheric air in order that an unnecessary pressure will not be applied to the analyzer. Otherwise, any pipe in the analyzer may be disconnected to cause gas leakage.
- For piping, use a pipe and a pressure reducing valve to which oil and grease are not adhering. If such a material is adhering, a fire or the like accident may be caused.

Observe the following when connecting the gas pipes.

- The pipes should be connected to the gas inlet and outlet at the rear panel of the analyzer, respectively.
- Connect the sampling system to the instrument by using corrosion-resistant tube such as Teflon, stainless steel, or polyethylene. In case where there is no danger of corrosion, don't use rubber or soft vinyl tube. Analyzer indication may become inaccurate due to the adsorption of gases.
- Piping connections are Rc1/4 or NPT1/4 female-threaded. Cut the pipe as short as possible for quick response. Pipe of \varnothing 4mm (inside diameter) is recommendable .
- If dust or gas with high water content enter into the instrument, malfunction may result. To prevent this, be sure to use clean pipes and joints.

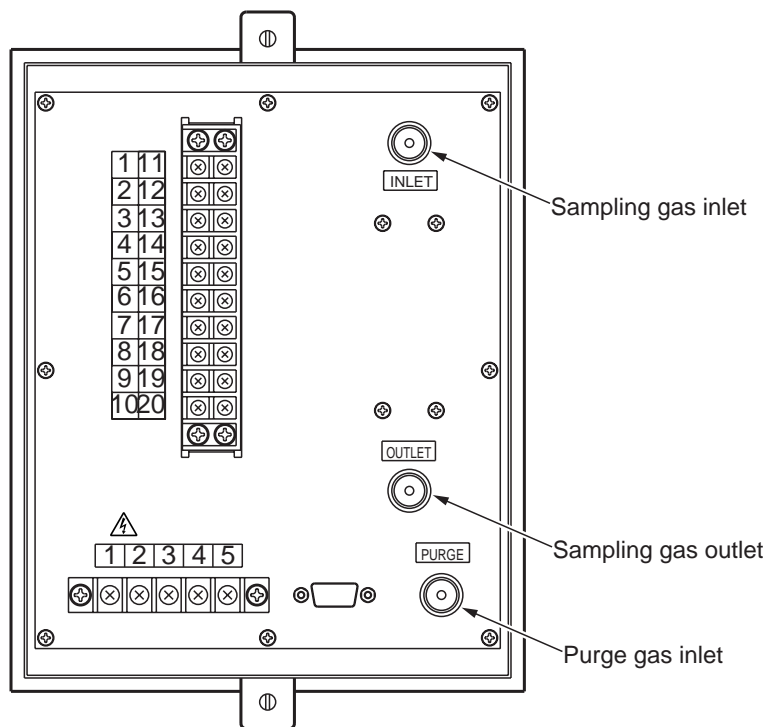

Fig. 3-1 Piping

Sampling gas inlet : Connect the pipe so that zero/span calibration standard gas or measured gas pretreated with dehumidification is supplied properly. The gas flow rate should be kept constant within the range of 0.4L/min \pm 0.05L/min. (High speed response: 1L/min \pm 0.05L/min)

Sampling gas outlet: Measured gas is exhausted after measurement. Connect the pipe so that the gas may escape through the gas outlet into the atmosphere or equivalent.

Purge gas inlet : It is used for purging the inside of the total gas analyzer. When the analyzer must be purged, refer to Item 3.4 (4), Purging inside Analyzer. Use dry gas N₂ or instrumentation air for purge gas. (flow rate of 1L/min should be used and dust or mist is not contained).

3.4 Sampling

(1) Conditions of sample gas

- ① The dust contained in sample gas should be eliminated completely with filters. The filter at the final stage should be capable of eliminating dust of 0.3 microne.
- ② The dew point of sample gas must be lower than the ambient temperature for preventing formation of drain in the analyzer. If water vapor is contained in sample gas, its dew point should be reduced down to about 0°C through a dehumidifier.
- ③ If SO₃ mist is contained in sample gas, the mist should be eliminated with a mist filter, cooler, etc. Eliminate other mist in the same way.
- ④ If a large amount of highly corrosive gas such as Cl₂, F₂ or HCl is contained in sample gas, the service life of analyzer will be shortened. So, avoid such gases.
- ⑤ Sample gas temperature is allowed within a range from 0 to 50°C. Pay attention not to flow hot gas directly into the analyzer.

(2) Sampling gas flow rate

A flow rate of sampling gas must be 0.4L/min ±0.05L/min (high speed response: 1L/min ± 0.05L/min).

A flow meter should be provided as shown in Fig. 3-1 Example of sampling system configuration.

(3) Preparation for standard gas

Prepare the standard gas for zero/span calibration.

When selecting the analyzer with reverse scale, use gas and span calibration gases of concentration shown on the attached analytical curve.

Zero gas	N ₂ gas
Span gas	Gas with concentration of 90% or more of full scale

(4) Purging of instrument inside

The inside of instrument need not be purged generally except for the following cases.

- ① A combustible gas component is contained in sample gas.
- ② Corrosive gas is contained in the atmospheric air at the installation site.
- ③ The same gas as the sample gas component is contained in the atmospheric air at the installation site.

In such cases as above, the inside of analyzer should be purged with the air for instrumentation or N₂.

Purging flow rate should be about 1L/min.

If dust or mist is contained in purging gas, it should be eliminated completely in advance.

(5) Pressure at sampling gas outlet

Pressure at the sampling gas outlet should be set to atmospheric pressure or equivalent.

(6) Example of sampling system configuration

The system configuration may vary depending upon the nature of measured gas, coexistent gases or application. A typical configuration diagram is shown in Fig. 3-1. Since a system configuration depends upon measured gas, consult with Fuji Electric Co..

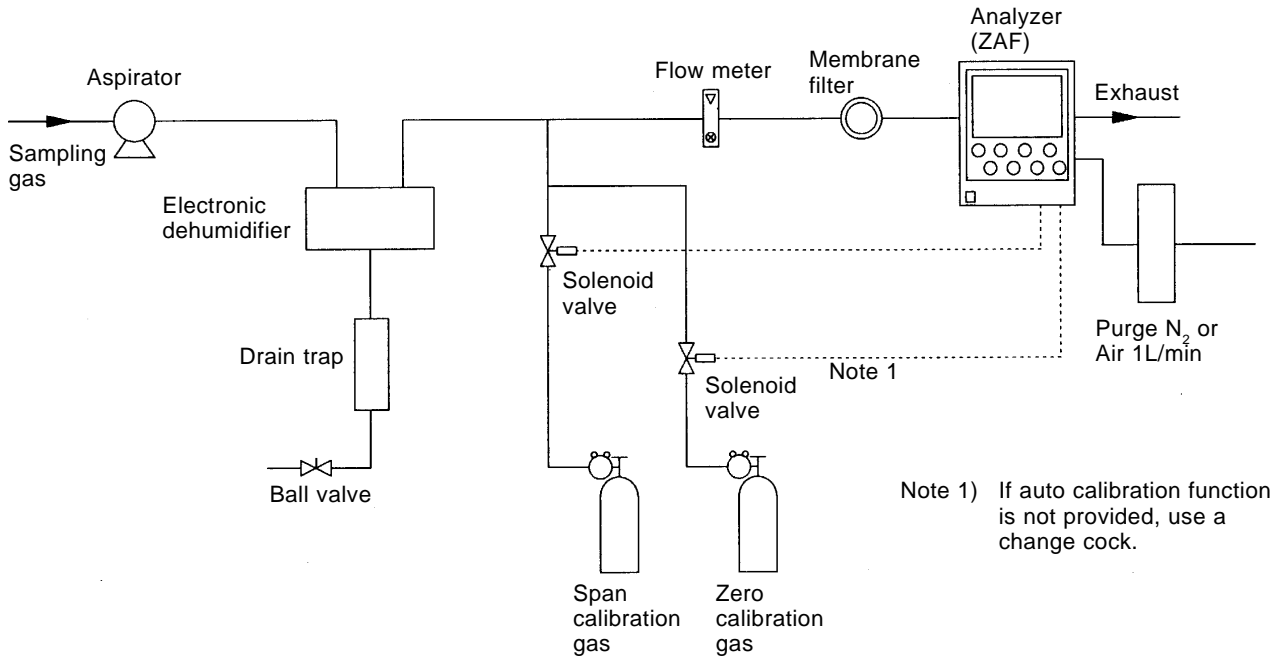

Fig. 3-1 Example of sampling system configuration

3.5 Wiring method

CAUTION

- Wiring work must be performed with the main power set to OFF to prevent electric shocks.
- Enforce construction of class-D grounding wire by all means.
If the specified grounding construction is neglected, a shock hazard or fault may be caused.
- Wires should be the proper one meeting the ratings of this instrument. If using a wire which cannot endure the ratings, a fire may occur.
- Be sure to use a power supply of correct rating. Connection of power supply of incorrect rating may cause fire.

The power terminal block and the external I/O terminal blocks are provided on the rear face of the analyzer. See the following figure.

Wire each terminal by referring to (1) to (7).

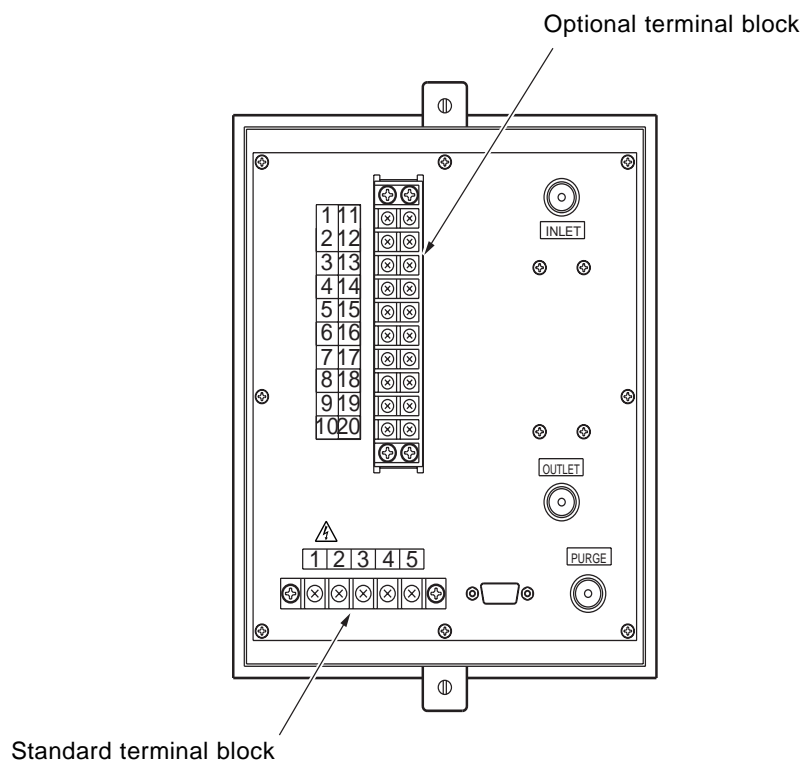

(1) Power supply (standard terminals ① – ②)

Connect the given power supply to the power terminal, and connect the ground wire to the grounding terminal (standard terminal ③). Perform class D grounding. Use solderless terminals (for M3.5) to connect the cables to the terminals.

Note) After the wiring work, be sure to place the protective cover for the terminal blocks to assure safety.

When noise source is in the vicinity

Do not install the analyzer near power noise generating electric equipment (such as high frequency furnace and electric welder). If the analyzer must be used near such equipment, a separate power line should be used for avoiding noise.

In case noise may enter from a relay, solenoid valve, etc. through power supply, connect a varistor or spark killer to the noise source as shown in right figure. If the varistor or spark killer is located away from the noise source, no effect is obtainable. So, locate near the noise source.

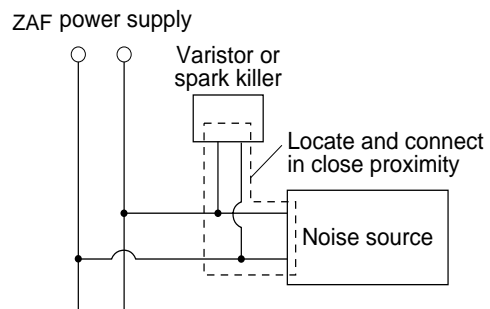

(2) Measured value output signal (standard terminals ④ – ⑤)

- Output signal : 4 to 20 mADC, 0 to 1 VDC, 0 to 10 mVDC (Can be select at the time of order placement.) Non-insulated output
- Allowable load : 4 to 20 mADC, 550Ω or less
0 to 1 VDC, 0 to 10 mVDC, 100kΩ or more

Note) Measurement output signals for this instrument are not isolated. To eliminate the interference from unnecessary signals and the effect of external interference, we recommend you to isolate signals.

(3) Measured value output signal (optional terminals ① – ②)

- Output signal : 4 to 20 mADC (Not selectable, fixed)
- Allowable load : 550Ω or less

Note) Measurement output signals for this instrument are not isolated. To eliminate the interference from unnecessary signals and the effect of external interference, we recommend you to isolate signals.

(4) Corrective input (optional terminals ③ – ④)

If interference corrective calculation is specified at the time of placement of an order, interference gas (CO₂ or CH₄) measured value is input.

1 to 5 VDC, 1 point

Note) The corrective input section of this instrument is not isolated. To eliminate the interference from unnecessary signals and the effect of external interference, we recommend you to isolate signals.

(5) **Contact input (optional terminals: DI1 ⑤ – ⑥, DI2 ⑦ – ⑧, DI3, ⑨ – ⑩)**

- Non-voltage contact input: Selecting ON/OFF closes/opens contact
- Don't apply voltage to terminals.

(6) **Contact output (optional terminals: DO1 ⑪ – ⑫, DO2 ⑬ – ⑭, DO3 ⑮ – ⑯, DO4 ⑰ – ⑱, DO5 ⑲ – ⑳)**

Contact capacity: 250V AC/2A resistive load

- Relay contact output: Selecting ON/OFF closes/opens contact

Note) To eliminate the effect of external interference, separate the power cable from the measured value output signal cable and contact input signal cable.

(7) **List of terminal blocks**

Standard terminal

1	L	}	Power supply 100 to 240V AC, 50/60Hz
2	N		
3	E	-	Grounding terminal
4	+	}	Measured value output (as specified) 4 to 20mA DC 0 to 1V DC 0 to 10mV DC
5	-		

Option terminal

Measured value output 4 to 20mA DC	┌ OUT+	1	11	DO1	┌ Contact output 1
	└ OUT-	2	12		
Interference correcting input 1 to 5V DC	┌ AIN+	3	13	DO2	┌ Contact output 2
	└ AIN-	4	14		
Remote output holding	┌ DI1	5	15	DO3	┌ Contact output 3
	└ DI1	6	16		
Remote range changeover	┌ DI2	7	17	DO4	┌ Contact output 4
	└ DI2	8	18		
Remote automatic calibration start	┌ DI3	9	19	DO5	┌ Contact output 5
	└ DI3	10	20		

Refer to "Input/output contact specifications" in Section 9.2 CODE SYMBOLS.

(9) Timing of calibration contact output

① In case of manual calibration

• Zero calibration

Pump ON/OFF contact

Zero calibration contact

Span calibration contact

Output hold function

(with hold ON setting)

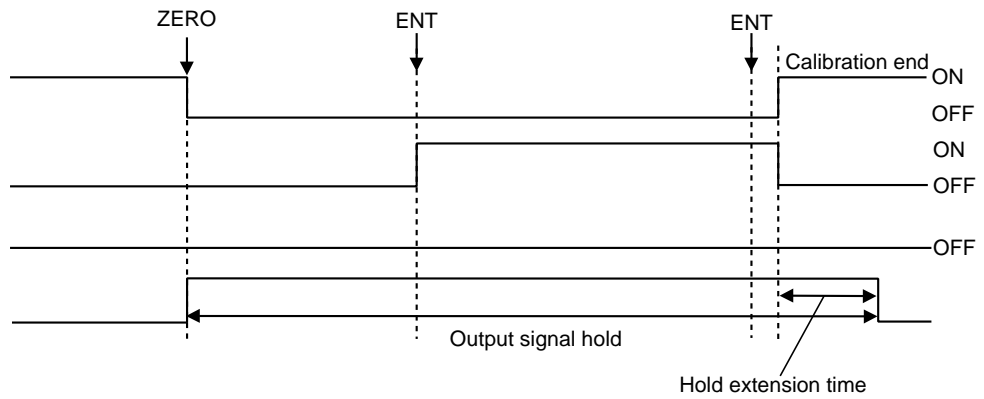

Note) The hold extension time depends on the gas flow time of the automatic calibration settings.

• Span calibration

Pump ON/OFF contact

Zero calibration contact

Span calibration contact

Output hold function

(with hold ON setting)

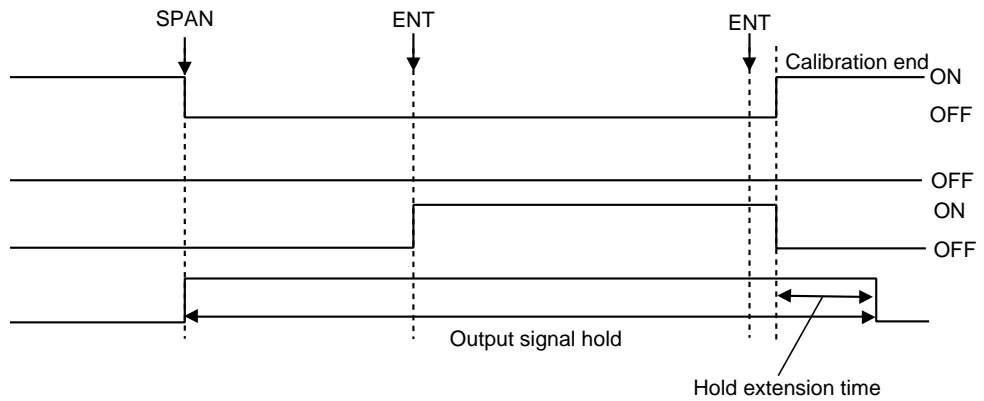

② In case of automatic calibration

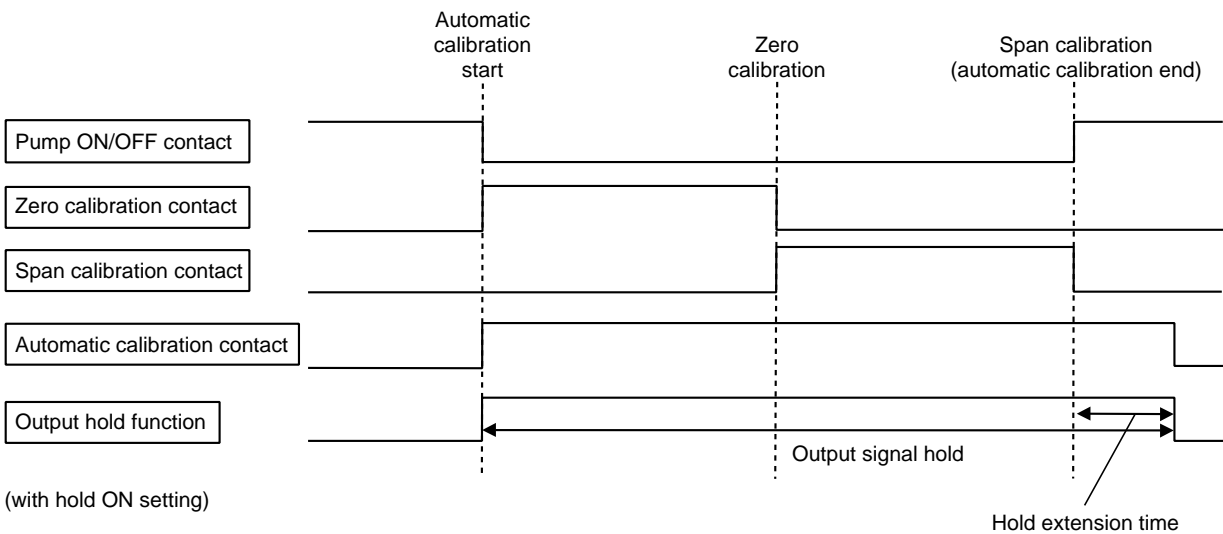

Hold extension time

4. OPERATION

4.1 Preparation for operation

(1) Check of gas sampling tube, exhaust tube and wiring

Check that the pipes are correctly connected to the gas sampling port and drain port. Check that the analyzer is correctly wired as specified.

4.2 Warm-up operation and regular operation

(1) Operation procedure

- ① Turn ON the power switch at the lower left of the front panel.

In one or two seconds, the measurement screen will appear at the front panel.

- ② About 30 minutes warm-up operation

About 30 minutes are needed until the operating performance is stabilized. Warm-up operation should be continued with the power ON.

- ③ Setting of various set values

Set required set values according to Chapter 6, "Setting and calibration".

- ④ Zero and span calibration

Perform zero calibration and span calibration after warm-up operation.

See Chapter 6.7, "Calibration".

- ⑤ Introduction and measurement of measured gas

Start measurement by introducing measured gas into the analyzer.

5. DESCRIPTION OF DISPLAY AND OPERATION PANEL

This section describes the display and operation panel of the gas analyzer.

5.1 Name and description of operation panel

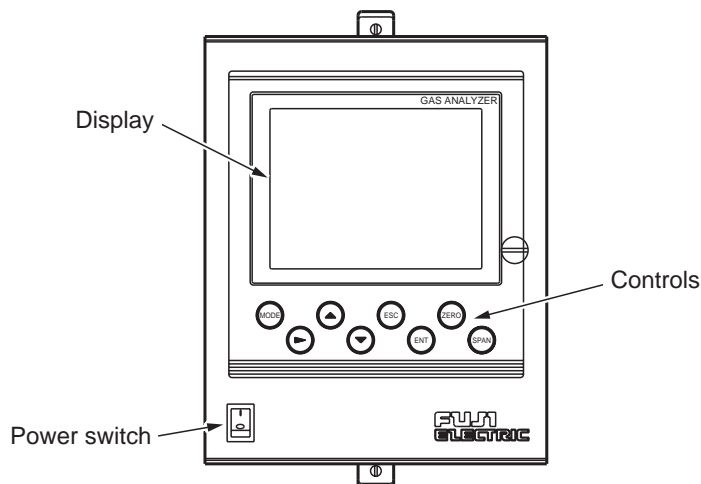

- Display : The measurement screen and the setting items are displayed.
- Controls : The configuration is as shown below.

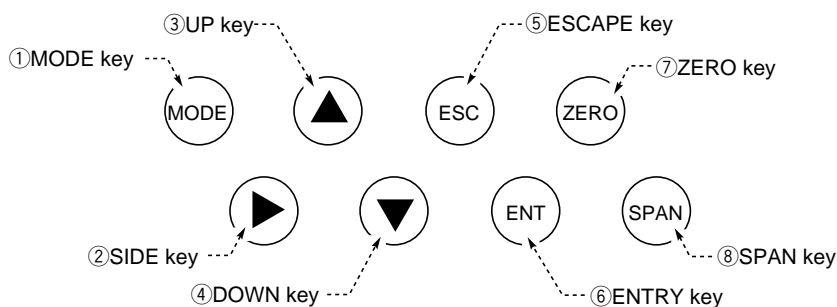

Name	Description	Name	Description
① MODE key	Used to display the measured value and to switch the Menu mode.	⑤ ESC key	Used to return to a previous screen or cancel the setting midway.
② SIDE key	Used to change the selected item (by moving the cursor) and numeral digit.	⑥ ENT key	Used for confirmation of selected items or values, and for execution of calibration.
③ UP key	Used to change the selected item (by moving the cursor) and to increase numeral value.	⑦ ZERO key	Used for zero calibration.
④ DOWN key	Used to change the selected item (by moving the cursor) and to decrease numeral value.	⑧ SPAN key	Used for span calibration.

Fig. 5-1 Name and description of operation display and panel

5.2 Overview of display and operation panel

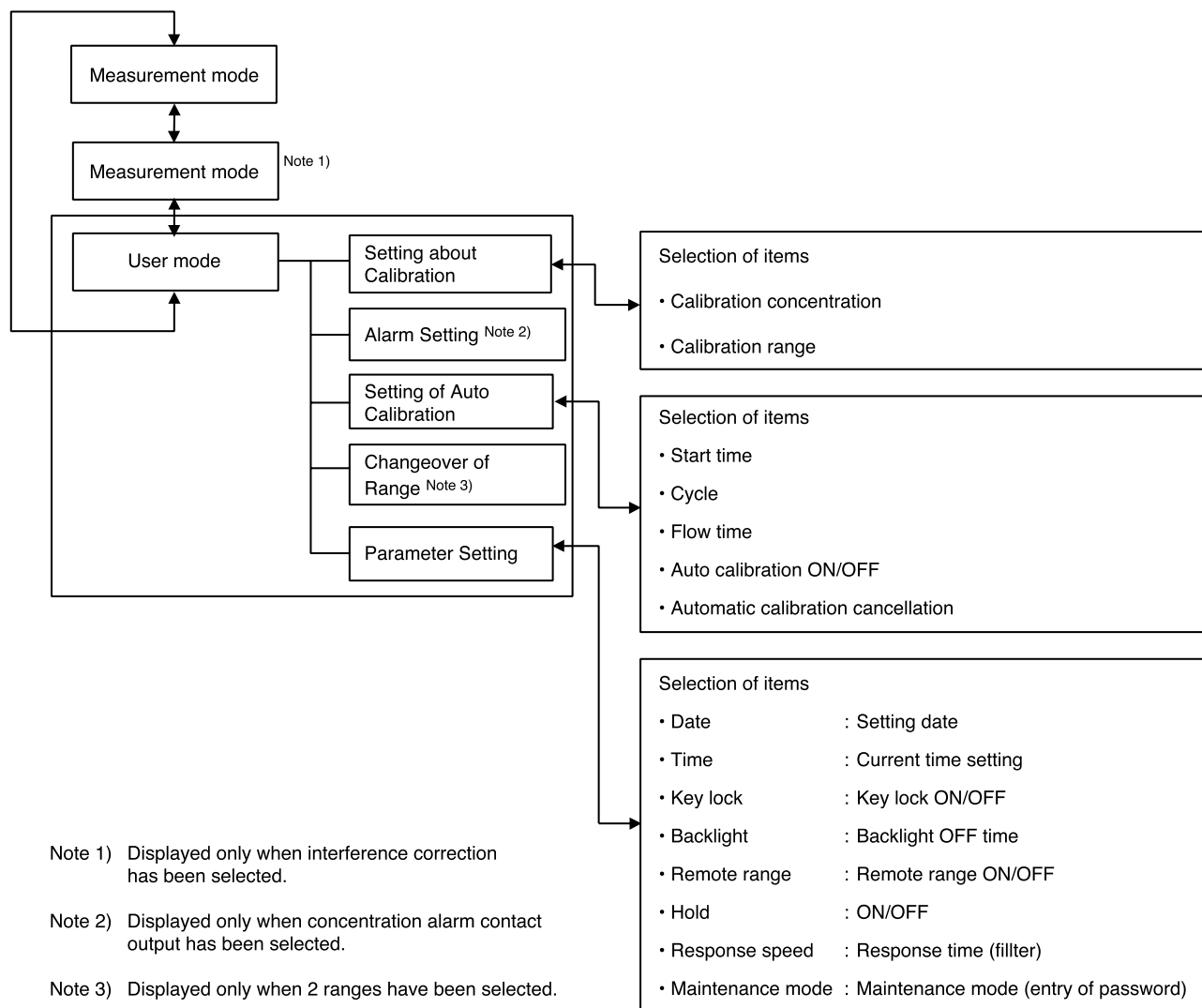
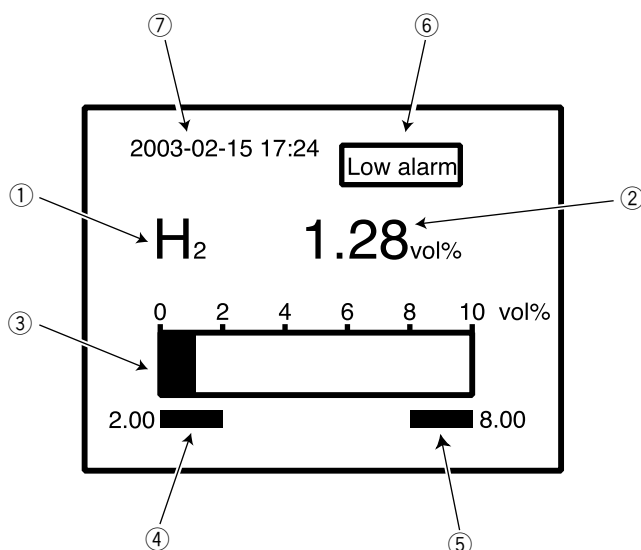





Fig. 5-2

5.3 Overview of display screen

(1) Measurement mode screen

Turning on the power switch displays the screen as shown below.
The contents of the display are as follows.





- ① Component display
Displays the component measured.
- ② Concentration display
Displays measured concentration value in volume percent.
Decimal place can be changed by pressing the  key.
- ③ Bar graph
Measured concentration values are displayed in a bar graph. The max. scale of the bar graph shows the selected measuring range.
- ④ Lower limit alarm concentration alarm (on selection of concentration alarm contact output)
The range and value of the lower limit alarm are displayed in a bar graph.
- ⑤ Upper limit concentration alarm (on selection of concentration alarm contact output)
The range and value of the upper limit alarm are displayed in a bar graph.
- ⑥ Alarm message
Displays an alarm message and outputs as contact output when measured concentration value falls within the alarm range.
- ⑦ Date and time display
Pressing the  or the  key displays or removes the date and time.

(2) Setting/selection screen

The setting/selection screen is configured as shown below:

- In the status display area, the current status is displayed.
- In the message display area, messages associated with operation are displayed.
- In the setting item and selection item display area, items or values to be set are displayed, as required.

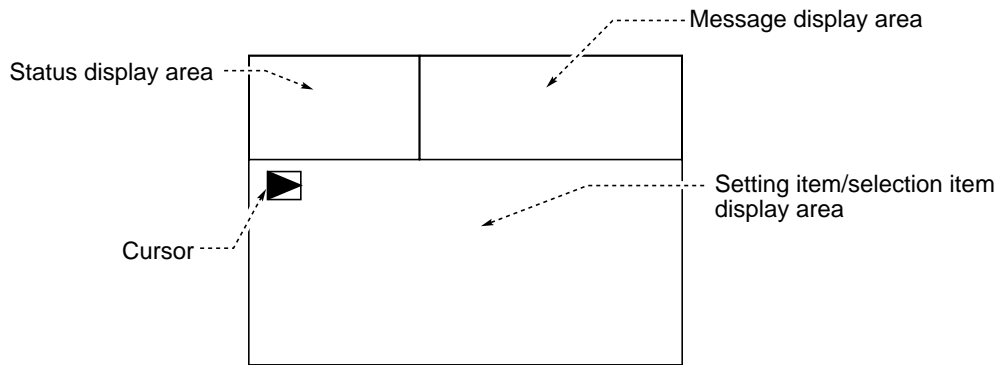

To work on the area, move the cursor to any item by using  ,  and  keys.



Menu Display screen

5.4 General operation

(1) Measurement mode

In measurement mode, the measured concentration value is displayed numerically and in bar graph. Press the  key or the  key to scroll the screen.

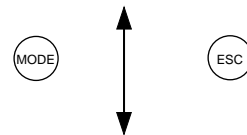
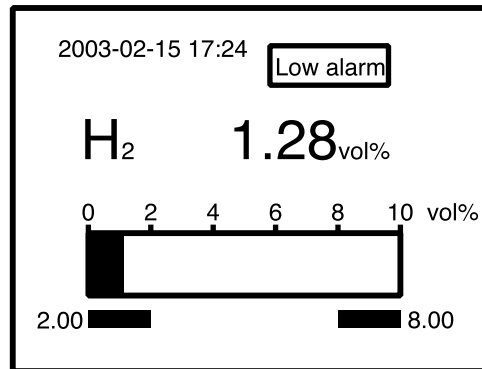

(2) Measurement mode (Displayed when interference corrective calculation has been selected.)

If interference corrective calculation has been specified, the measurement values before and after the interference correction and interference gas concentration value are displayed as shown in the figure at right.

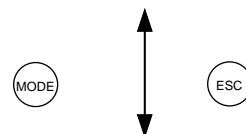
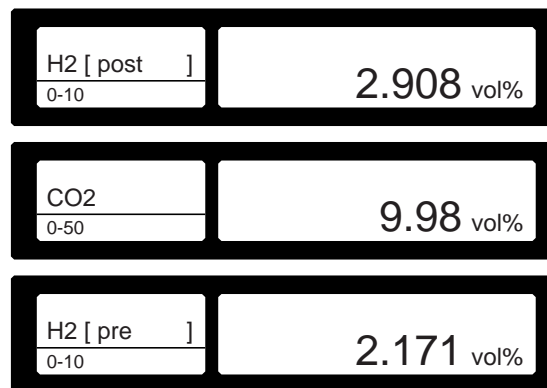

(3) User mode

In user mode, the setting menu is displayed.

- Calibration setting
- Alarm setting
(on selection of concentration alarm contact output)
- Auto calibration setting
- Range changeover
(on selection of 2-range meter)
- Parameter

Refer to 6. SETTING AND CALIBRATION for the setting method.

User Mode	Select an item with UP/DOWN and ENT Back with ESC
<ul style="list-style-type: none"> <input checked="" type="checkbox"/> Setting about Calibration Alarm Setting Setting of Auto Calibration Changeover of Range Parameter Setting 	



6. SETTING AND CALIBRATION

6.1 Calibration setting



Calibration setting is made to select the concentration at calibration and calibration operation for the range.

6.1.1 Setting of calibration concentration



Select the concentration of standard gases (zero gas, span gas) used at the time of calibration following the procedures shown below.



- (1) Press the MODE key in measurement state to display the User Mode screen. Move the cursor to Calibration Setting by pressing the  or the  key and then press the  key.

User Mode	Select an item with UP/DOWN and ENT Back with ESC
 Setting about Calibration Alarm Setting Setting of Auto Calibration Changeover of Range Parameter Setting	

- (2) In the calibration setting item screen that appears, move the cursor to Calibration Value by pressing the  or the  key, and then press the  key.

Cal. Settings	Select an item with UP/DOWN and ENT Back with ESC
 Calibration Value About Calibration Range	

- (3) Select the concentration item you want to make the setting by pressing the ,  or the  key.





- (4) Enter zero and span calibration gas concentration by using the  or the  key, and then press the  key.

To close calibration setting
 To close calibration setting or terminate the operation, press the  key, and you will return to the previous screen.



Cal. Settings Cal. Value	Select setting value	
H ₂		
RANGE	ZERO	SPAN
0-3vol%	 0 0 . 0 0	2 . 9 1 0
0-10vol%	0 0 . 0 0	0 9 . 8 1

6.1.2 Setting of calibration range

This mode is used to set if the range of each CH (component) at the calibration (manual calibration or auto calibration) should be calibrated with a single range or 2 ranges.

- (1) During measurement, press the  key to display the User mode. Point the cursor to “Setting about Calibration” by pressing the  or  key. Press the  key.

User Mode	Select an item with UP/DOWN and ENT Back with ESC
 Setting about Calibration Alarm Setting Setting of Auto Calibration Changeover of Range Parameter Setting	

- (2) In the “Setting about Calibration” screen that appears, point the cursor to “About Calibration Range” by pressing the  or  key. Press the  key.

Cal. Settings	Select an item with UP/DOWN and ENT Back with ESC
Calibration Value  About Calibration Range	

- (3) Press the  key on the calibration range action set screen.
Range 1 is displayed only with 1-range meter.

Cal. Settings Cal. Range	ENT : Select cal. range ESC : Back		
 H ₂	Range1	0–3 vol%	current
	Range2	0–10 vol%	

(4) In the “Calibration Range” screen that appears, select “Both” or “Current” (for 2 ranges) and press the **ENT** key.

- When selecting “both”, Range 1 and Range 2 are calibrated together.
- When selecting “Current”, the range alone displayed is calibrated.

To close “Setting of Calibration Range”
To close “Setting of Calibration Range” or to cancel this mode midway, press the **ESC** key. A previous screen will return.

Cal. Settings		Set calibration range	
Cal. Range		current or both range	
H ₂	Range1	0–3 vol%	current
	Range2	0–10 vol%	

Select “both” or “current” pressing by the **▲** or **▼** key.

Note) When calibration is performed by the “Both” setting under the normal operating condition, prepare a span gas cylinder on the normal operating range side. It is recommend to perform span gas calibration in the normal operating range.

Manual Calibration screen

In case of “both” setting





ZERO Cal.		ENT : Gas floes ESC : Back	
H ₂	Range1	▶ 0–3 vol%	▢ 1.28
	Range2	0–10 vol%	▢

Two cursors will appear in both ranges



6.2 Alarm setting (When concentration alarm contact output has been selected)

6.2.1 Setting of alarm values





This mode is used to set the upper and lower limit value to provide an alarm output during measurement. Before changing the alarm setting, set the ON/OFF to OFF. Then set the ON/OFF to On again.

- ① During measurement, press the  key to display the User mode. Point the cursor to "Alarm Setting" by pressing the  or  key. Press the  key.

User Mode	Select an item with UP/DOWN and ENT Back with ESC
Setting about Calibration  Alarm Setting Setting of Auto Calibration Changeover of Range Parameter Setting	

- ② After the Alarm Setting screen has appeared, operate the  or  key until the cursor is aligned with a desired item and press the  key. "DO3" is an output terminal number.

Alarm Setting	Select an item with UP/DOWN and ENT Back with ESC
 Upper Range 1 0.900 vol% DO3 Range 2 03.00 vol% Lower Range 1 0.200 vol% DO3 Range 2 01.00 vol% Kind of Alarm Upper+Lower Hysteresis 00%FS ON/OFF OFF	

- ③ Enter the setting value pressing the ,  or  key. And then press the  key.

To close "Alarm setting"
To close "Alarm setting" or to cancel this mode midway, press the  key. A previous screen will return.

Alarm Setting	Set value
Upper Range 1 0.900 vol% DO3 Range 2  03.00 vol% Lower Range 1 0.200 vol% DO3 Range 2 01.00 vol% Kind of Alarm Upper+Lower Hysteresis 00%FS ON/OFF OFF	

Description of setting items

Upper limit value : Sets the upper limit value (concentration) of alarm by range.

Lower limit value: Sets the lower limit value (concentration) of alarm by range.

- Contact action : ① Upper limit value
Alarm contact operates only when the upper limit value is exceeded (1 point).
- ② Lower limit value
Alarm contact operates only when the measurement falls below the lower limit value (1 point).
- ③ Upper limit/Lower limit value
Alarm contact operates when measured value exceeds the upper limit value, or it falls below the lower limit value (1 point).
- ④ Upper limit value + Lower limit value
Alarm contact operates when measured value exceeds the upper limit value, or falls below the lower limit value (2 points).
- ⑤ Two-step upper limit value
Alarm contact operates alarm only when measured value exceeds two kinds of upper limit values.
- ⑥ Two-step lower limit value
Alarm contact operates only when measured value falls below two kinds of lower limit values.

ON/OFF: Alarm function becomes valid with ON, and invalid with OFF.









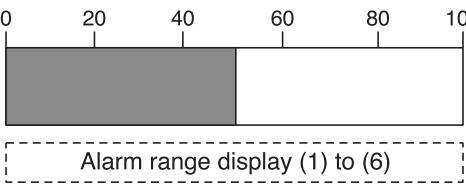

* The upper limit value cannot be set below the lower limit value, and the lower limit value cannot be set above the upper limit value.

If you want to set the upper limit value below the lower limit value already stored in the memory, decrease the lower limit value first, and then make the setting. In the case of lower limit value, increase the upper limit value before making the setting.

Make the setting for contact operation according to the types of contact selected in “6.6.5 Contact output setting.”

Select the type of contact operation and make the setting for the above alarm values, and the alarm range is displayed under the bar graph concentration display as shown in (1) to (6) of the following table. (See the next page.)

Contact operation selection items and alarm display

Contact operation selection item	Bar graph and alarm display screen	Contact output
		<p>Contact output</p> <p>* Refer to "6.6.5 Contact output setting" for the setting and assignment of contact outputs.</p>
(1) Upper limit value	<p>Upper limit 1 alarm </p>	<p>One point (Select one upper limit 1 alarm.)</p>
(2) Lower limit value	<p> Lower limit 1 alarm</p>	<p>One point (Select one lower limit 1 alarm.)</p>
(3) Upper or lower limit value	<p> Upper or lower limit alarm </p>	<p>One point (Select one upper limit or lower limit alarm.)</p>
(4) Upper limit value + Lower limit value	<p>Lower limit 1 alarm  Upper limit 1 alarm </p>	<p>Two points (Select one upper limit 1 and one lower limit 1 alarms.)</p>
(5) Two-step upper limit value	<p>Upper limit 1 alarm  Upper limit 2 alarm </p>	<p>Two points (Select one upper limit 1 and one upper limit 2 alarms.)</p>
(6) Two-step lower limit value	<p> Lower limit 1 alarm  Lower limit 2 alarm</p>	<p>Two points (Select one lower limit 1 and one lower limit 2 alarms.)</p>

On-screen display when an alarm occurs

When the lower limit alarm occurs, the "Low alarm" message is displayed above the measured value.
(In case of upper limit alarm, "High alarm" is displayed).

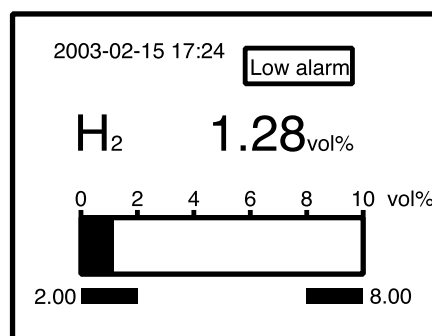

Caution

- For 10 minutes after turning on power, the alarm judgment is inactive.

6.2.2 Hysteresis setting

To prevent chattering of an alarm output near the alarm setting values, set hysteresis.

- ① During measurement, press the **(MODE)** key to display the User mode. Point the cursor to "Alarm Setting" by pressing the **(▲)** or **(▼)** key. Press the **(ENT)** key.

User Mode	Select an item with UP/DOWN and ENT Back with ESC
Setting about Calibration <input checked="" type="checkbox"/> Alarm Setting Setting of Auto Calibration Changeover of Range Parameter Setting	

- ② In the Alarm Setting screen that appears, select "Hysteresis" by pressing the **(▲)** or the **(▼)** key, and press the **(ENT)** key. Enter a numeric value by using the **(▲)**, **(▼)** or the **(▶)** key, and then press the **(ENT)** key.

Alarm Setting	Select an item with UP/DOWN and ENT Back with ESC
Upper Range 1 0.900 vol% DO3 Range 2 03.00 vol% Lower Range 1 0.200 vol% DO3 Range 2 01.00 vol% Kind of Alarm Upper+Lower <input checked="" type="checkbox"/> Hysteresis 00%FS ON/OFF OFF	

To close Hysteresis Setting

To close the "Hysteresis Setting" or cancel the mode midway, press the **(ESC)** key. A previous screen will return.

Setting range

0 to 20% of full scale
 A full scale means each range provides a full scale of width.

Hysteresis



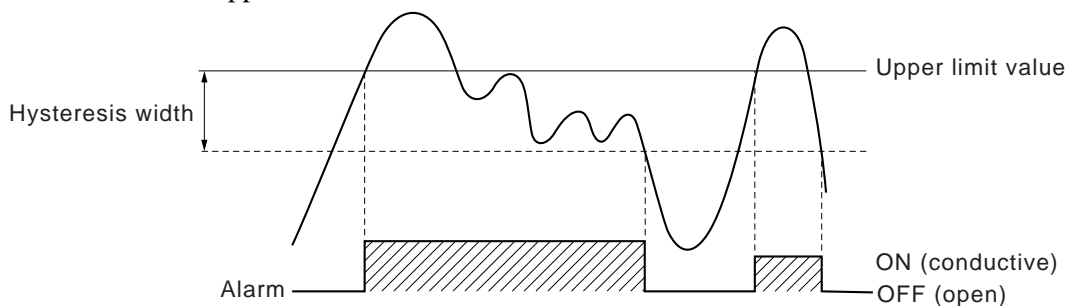

If hysteresis values exceed the upper limit value as shown in graph, an alarm output is provided. Once the alarm output is turned ON, it remains ON until the value falls below the set lower limit of the hysteresis indication. Alarm output is turned ON from the OFF state when the upper limit value is exceeded.









6.3 Setting of auto calibration (When auto calibration contact output has been selected)

6.3.1 Auto calibration

Auto calibration is automatically carried out when zero calibration and span calibration are set.
Before changing the setting of auto calibration, set the ON/OFF to OFF.

- ① During measurement, press the  key to display the User mode.
Point the cursor to "Setting of Auto Calibration" by pressing the  or  key. Press the  key.

User Mode	Select an item with UP/DOWN and ENT
Setting about Calibration Alarm Setting <input checked="" type="checkbox"/> Setting of Auto Calibration Changeover of Range Parameter Setting	

- ② In the Auto Calibration Setting screen that appears, select the item you want to make the setting by pressing the  or the  key, and then press the  key. Make the setting for each item by using the ,  or the  key, and then press the  key.

About Auto Cal.	Select setting item
<input checked="" type="checkbox"/> Start Time SUN 12 : 00 Cycle 07 day Flow Time 300 sec. ON/OFF OFF <div style="text-align: right;">Time : MON 17 : 24</div>	
Stop Auto Calibration	

To close Setting of Auto calibration
To close the "Setting of Auto calibration" or cancel this mode midway, press the  key.
A previous screen will return.

Description of setting items

- Start Time : Setting at the first calibration (day of the week, hour, minute)
- Cycle : A period between the start time of one calibration and another (unit : hour/day)
- Flow Time: Time required for feeding calibration gas to the detector unit.
- ON/OFF : Auto zero calibration ON or OFF

The contact outputs are closed during calibration/contact output calibration, and are open in other cases.
If hold is set to ON, the contacts are closed while the measurement value is in HOLD status.

Setting range

- Cycle : 1 to 99 hours or 1 to 40 days (initial value 7days)
Flow time : 60 to 599 sec (initial value 300sec)

Caution

- When an auto calibration starts, the measurement screen automatically appears.
- Any operation other than forced stop of auto calibration (see Item 6.3.2) is not permitted during auto calibration. “Auto Calibration Cancel” cannot be performed with the key lock to ON. To cancel auto calibration forcedly, set the key lock to OFF and then execute “Auto Calibration Cancel”.

Remote start

Whether the auto calibration is set at ON or OFF, an auto calibration is available by keeping the remote start input short-circuited for at least 1.5 seconds.

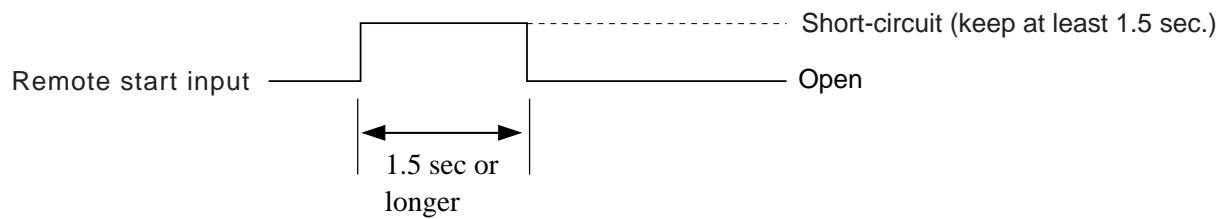

6.3.2 Forced stop of auto calibration

This mode is used to cancel the auto calibration forcedly.

- ① During measurement, press the **(MODE)** key to display the User mode. Point the cursor to “Setting of Auto Calibration” by pressing the **(▲)** or **(▼)** key. Press the **(ENT)** key.

User Mode	Select an item with UP/DOWN and ENT
Setting about Calibration Alarm Setting ▶ Setting of Auto Calibration Changeover of Range Parameter Setting	

- ② In the “Setting of Auto Calibration” item selection screen that appears, point the cursor to “Stop Auto Calibration” by pressing the **(▲)** or **(▼)** key. Press the **(ENT)** key.

About Auto Cal.	Select setting item
Start Time SUN 12 : 00 Cycle 07 day Flow Time 300 sec. ON/OFF OFF Time : MON 17 : 24	
▶ Stop Auto Calibrati	

- ③ “Stop Auto Calibration” is inverted. A message appears, prompting you to verify that you want to cancel or continue auto calibration. To cancel the auto calibration, press the **(ENT)** key. If you press the **(ESC)** key, auto calibration is not stopped.

About Auto Cal.	Stop auto calibration? Stop with ENT Not with ESC
Start Time SUN 12 : 00 Cycle 07 day Flow Time 300 sec. ON/OFF OFF Time : MON 17 : 24	
Stop Auto Calibrati	

6.4 Changeover of range (When 2 ranges have been selected)

This mode is used to select the ranges of measured components.

- ① During measurement, press the **(MODE)** key to display the User mode.
Point the cursor to “Changeover of Range”. Press the **(ENT)** key.

User Mode	Select an item with UP/DOWN and ENT
Setting about Calibration Alarm Setting Setting of Auto Calibration ▶ Changeover of Range Parameter Setting	

- ② On the Range Change screen that appears, press the **(ENT)** key to change over the range.

Range Change	ENT : Select range ESC : Back
▶ H ₂	Range1 0–3 vol%
	Range2 0–100 vol%

- ③ Select the range you want to set by using **(▲)** or **(▼)** key and press the **(ENT)** key. Measurement can be made within the range selected.
In this case, the range identification signal is active (ON) with the Low range (Range 1) and inactive (OFF) with the High range (Range 2).

Range Change	Select range with UP/DOWN and ENT Back with ESC
H ₂	Range1 ▶ 0–3 vol%
	Range2 0–100 vol%

Note) When the remote range is set to ON, range changeover is not allowed on the screen.

To close the setting

To close the Changeover of range setting process or cancel this mode midway, press the **(ESC)** key. A previous screen will return.





6.5 Parameter setting

It allows you to carry out the parameter setting such as time, key lock, etc., as required. Items to be set are as follows:



Description of setting items

- Date : Sets the date.
- Current Time : Sets the current day of the week, hour and time.
- Key Lock : Sets with ON/OFF so that any key operation except the key lock OFF cannot be performed.
- Backlight : Automatic OFF time of the backlight in the display unit
- Remote Range : Sets with ON/OFF whether the Range Selection is made valid or invalid by external input.
- Output Hold : Sets whether Calibration Output is held or not.
- Average Value Reset : Resets the average value.
- Response Speed : Sets the response time of electrical system.
- Average Time : Sets the moving average time.
- Maintenance mode : Enters passwords to switch to the Maintenance mode.

* For the maintenance mode, see Item 6.6 Maintenance mode.

- ① To display the User mode, press the  key in the measurement mode. Point the cursor to "Parameter Setting" by pressing the  or  key. Press the  key.

User Mode	Select an item with UP/DOWN and ENT
	Setting about Calibration Alarm Setting Setting of Auto Calibration Changeover of Range  Parameter Setting

- ② In the "Parameter Setting" screen that appears, point the cursor to any item you want by pressing the  or  key. Press the  key.

Parameter Setting	Select setting item
 Current Date	2003-09-08
Current Time	MON 16 : 19
Kye Loc	OFF
Back Light	ON 99min
Output Hold	OFF
Response Time	01 sec.
To Maintenance Mode	0000

To close Parameter Setting screen

To close the "Parameter Setting" screen or cancel this mode midway, press the  key. A previous screen will return.

Setting range

- Backlight : 5 to 99 min (Initial value: 10 min)
- Response time : 1 to 60sec. (Initial value: 3 sec)
- Maintenance mode : 0000 to 9999 (Initial value: 0000)

Backlight

According to the set time, the backlight in the display unit is turned off. Unless key operation is performed during the set time period, the backlight is automatically turned off. By pressing an arbitrary key, the backlight is turned on.

Remote Range

A range can be switched via an external input by setting the Remote Range to ON. If the Remote Range is set to OFF, the external input becomes invalid.

Opening the input gives the High range, or short-circuiting the input gives the Low range.

Note) In case of 1 range system, this function is overridden.

Output Hold

By setting an output hold to ON, an output signal of each channel are held during the calibration (manual calibration and auto calibration) and for the gas flow time. Regardless of Hold ON/OFF setting, an output signal can be held via an external input.

(1) Manual calibration

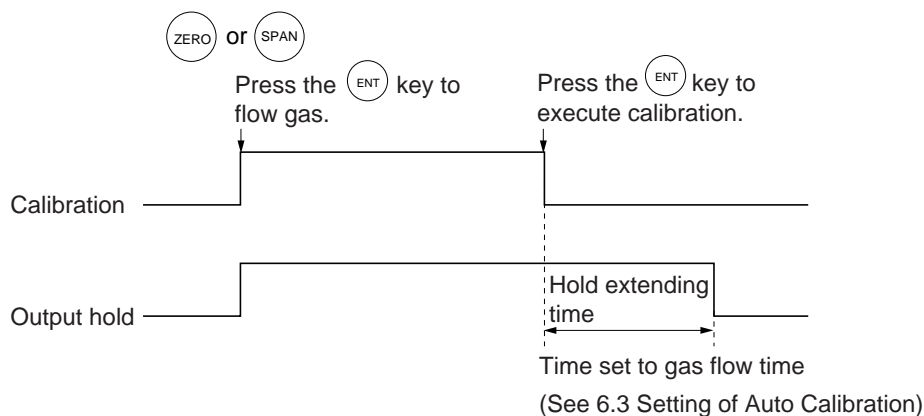

(2) Auto calibration

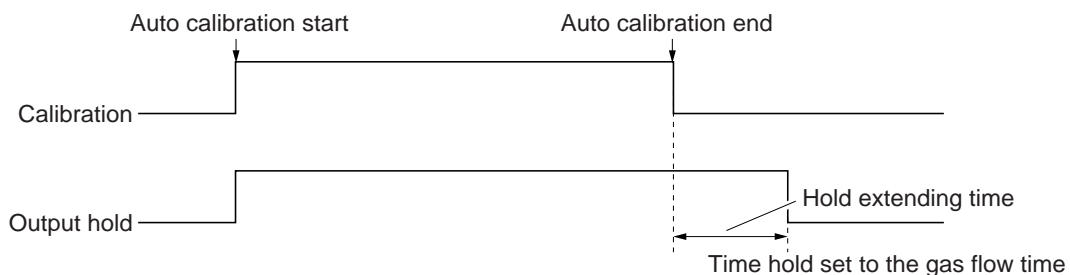

(3) Screen display during holding

The “Holding” message blinks on the measuring screen.

Since the screen displays the process of calibration is displayed during the manual calibration, “Holding” is not displayed even if the screen is held, but the screen is displayed with the hold extending time.

(4) While in calibration

Irrespective of being in manual or automatic mode, if calibration operation is canceled after the calibration gas is supplied, an output hold of the holding extending time will be performed.

Response time

The response time of the electrical system can be changed.

Note) It does not provide exact seconds for the setting time, but it gives a guide of the setting time.

The setting value can be modified as requested by the customer.

Maintenance mode



To open the maintenance mode, enter a password. After entering the password, press the  key.

The password can be used for the Password Setting in the Maintenance mode. A password is set to “0000” before factory-shipment. This value is available for the Maintenance mode.

6.6 Maintenance mode

In maintenance mode, if you register a password, you must enter the password from the next operation on. You can enter the maintenance mode by selecting the maintenance mode in “6.5 Parameter Setting”

- **How to enter the Maintenance mode.**

- (1) During measurement, press the  key to display the user mode.
Point the cursor to “Parameter”. Press the  key.

User Mode	Select an item with UP/DOWN and ENT
Setting about Calibration Alarm Setting Setting of Auto Calibration Changeover of Range <input checked="" type="checkbox"/> Parameter Setting	

- (2) In Parameter Setting screen that appears, point the cursor to “Maintenance Mode”. Press the  key.

Parameter Setting	Select setting item
Current Date	2003-09-08
Current Time	MON 16 : 19
Kye Loc	OFF
Back Light	ON 99min
Output Hold	OFF
Response Time	01 sec.
<input checked="" type="checkbox"/> To Maintenance Mode	0000

- (3) The cursor moves to the field where you can enter the password. Leave the field as “0000” and press the  key.

Caution

If a password has been registered, enter the password.

Parameter Setting	Input Password to Maintenance Mode
<input checked="" type="checkbox"/> Current Date	2003-09-08
Current Time	MON 16 : 19
Kye Loc	OFF
Back Light	ON 99min
Output Hold	OFF
Response Time	01 sec.
To Maintenance Mode	<input type="text" value="0000"/>

(4) Next, the Maintenance Mode screen is displayed.

Note) “To Factory Mode” is used for our service engineers only. Refrain from using this mode.

Maintenance Mode	Select operating item
<input checked="" type="checkbox"/> 1. Sensor Input Value 2. Error Log 3. Password Setting 4. Station No. 01 5. Setting of Digital Out 6. Cal. history 7. To Factory Mode	

6.6.1 Sensor input value screen

H2 : Sensor input value
 (The display changes depending on measured component. Ex.: H2)

Temperature : Temperature sensor input value





Maintenance Sensor Input			
	sensor	input	
	H2	33140	9.1 vol%
	TEMP	30624	35.8 °C

6.6.2 Error log file





The error log file displays the history of error occurrence with error No. and the date and time of occurrence (day of the week and time). Refer to “8.1 Error message” for the contents of errors.

Maintenance Error Log	ENT : Clear Error Log ESC : Back		
Error No. 4 WED 11 : 09 H2 Error No. 5 WED 11 : 09 H2 Error No. 4 WED 11 : 07 H2 Error No. 7 WED 10 : 58 H2 Error No. 6 WED 10 : 23 H2 Error No. 7 WED 10 : 23 H2 Error No. 7 WED 10 : 09 H2 ▼Next page page. 1			
<input checked="" type="checkbox"/> Clear Error Log			

6.6.3 Password setting

- (1) Press the  key in measurement state to display the User mode screen. Press the  or the  key to move the cursor to "Password Setting" and then press the  key.

Maintenance Mode	Select operating item
	<ol style="list-style-type: none">1. Sensor Input Value2. Error Log 3. Password Setting4. Station No. 015. Setting of Digital Out6. Cal. history7. To Factory Mode

- (2) In the Password Setting screen that appears, enter the password by pressing the ,  or  key, and press the  key.

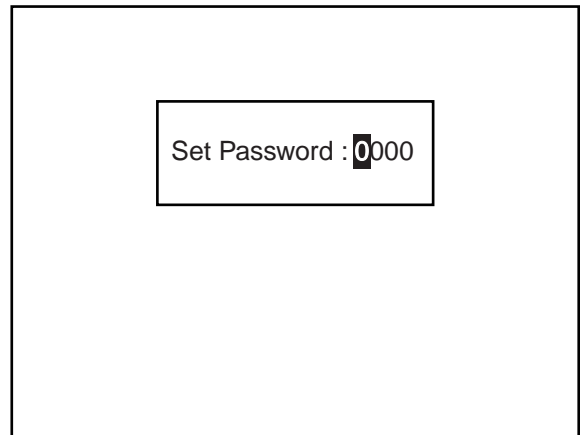

To close "Pssword setting"

To close "Password setting" or to cancel this mode midway, press the  key. A previous screen will return.

Caution

Be sure to remember the password.

6.6.4 Station No. setting (When RS232C transmission has been selected)

- (1) Press the **(MODE)** key in measurement state to display the User mode screen. Press the **(▲)** or the **(▼)** key to move the cursor to Station No. and then press the **(ENT)** key.

Maintenance Mode	Select operating item
<ol style="list-style-type: none"> 1. Sensor Input Value 2. Error Log 3. Password Setting ▣ 4. Station No. 01 5. Setting of Digital Out 6. Cal. history 7. To Factory Mode 	

- (2) In the station No. setting screen that appears, enter the station No. by pressing the **(▲)**, **(▼)** or **(▶)** key, and press the **(ENT)** key.

Maintenance Mode	Set Station No. Allowable 00 to 31
<ol style="list-style-type: none"> 1. Sensor Input Value 2. Error Log 3. Password Setting 4. Station No. 01 5. Setting of Digital Out 6. Cal. history 7. To Factory Mode 	





To close "Station No. setting"

To close "Station No. setting" or to cancel this mode midway, press the **(ESC)** key. A previous screen will return.



6.6.5 Contact output setting

(Can be selected on the code symbols. When contact output has been selected.)



Select the functions to be assigned to contact outputs (DO1 to DO5). Follow the procedures shown below.

- (1) Press the  key in measurement state to display the User mode screen. Press the  or the  key to move the cursor to “Setting of Digital Out” and then press the  key.

Maintenance Mode	Select operating item
	1. Sensor Input Value 2. Error Log 3. Password Setting 4. Station No. 01 5. Setting of Digital Out* 6. Cal. history 7. To Factory Mode

- (2) In the Setting of Digital Out screen that appears, select a desired item by pressing the  or the  key, and press the  key.
Now you can change the setting.

Maintenance Digital Out	Select an item
	DO1 zero valve DO2 span valve DO3 HL alarm DO4 on calib. DO5 fault

- (3) Select a desired item by pressing the  or the  key, and then press the  key.

Note) Check the output terminal block carefully against the contents of the setting.

Maintenance Digital Out	Select a function
	DO1 zero valve DO2 span valve DO3 HL alarm DO4 on calib. DO5 fault

Correspondence between contact outputs and the terminal numbers of the external terminal block is as follows.

- DO1 ⑪ – ⑫
- DO2 ⑬ – ⑭
- DO3 ⑮ – ⑯
- DO4 ⑰ – ⑱
- DO5 ⑲ – ⑳

The following functions can be assigned. The contacts operate according to the selection of the code symbols in 9.2.

- “Range information”
- “Upper and lower limit alarm”
- “Lower limit 2 alarm”
- “Lower limit 1 alarm”
- “Upper limit 1 alarm”
- “Pump”
- “Calibration in progress”
- “Span valve”
- “Zero valve”
- “OFF”
- “Analyzer error”

The setting of the instrument has been made as follows at the time of delivery from the factory. Change the setting as required.

List of contact output assignment at delivery time

14th digit Type of contact	A	B	C	D	E	F
Zero valve	DO1	DO1			DO1	DO1
Span valve	DO2	DO2			DO2	DO2
Pump	DO3	DO3				
Upper limit 1 alarm			DO1	DO1		
Lower limit 1 alarm			DO2	DO2		
Upper and lower limit alarm					DO3	DO3
Upper limit 2 alarm						
Lower limit 2 alarm						
Calibration in progress	DO4	DO4	DO4	DO4	DO4	DO4
Range information			DO3	DO3		
Analyzer error	DO5	DO5	DO5	DO5	DO5	DO5

6.6.6 Calibration history

The calibration history screen displays the history of calibration. Calibration history of up to 10 items can be recorded. Every time a new calibration is performed in this state, the oldest calibration history is deleted.

Factory Mode Cal. history								
	coe.	input	Y	M	D	H	M	S
ZERO	+00208	39794	3	3	17	11	40	7
SPAN	1.0699	44492	3	3	13	10	54	35

6.7 Manual calibration

6.7.1 Zero calibration

It is used for zero point adjustment. For zero calibration gas, see 3.4 (3), Preparation for standard gas in sampling. Use a gas according to application.

- (1) Press the **ZERO** key on the measurement screen to display the Zero Calibration screen.

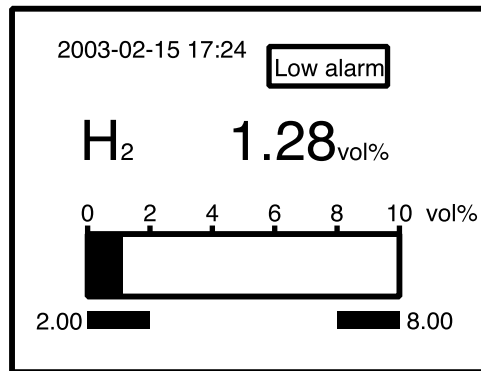

- (2) Pressing the ENT key turns ON the contact for zero calibration.

Caution

If "Both" has been selected for "Calibration range action", calibration is carried out in both ranges simultaneously.

ZERO Cal.	ENT : Gas flows ESC : Back	
▶ H ₂	Range1 ▶ 0-3 vol%	1.28
	Range2 0-10 vol%	

- (3) Wait until the indication is stabilized with the zero gas supplied. After the indication has been stabilized, press the **ENT** key. Zero calibration in range selected by the cursor is carried out.

To close Zero Calibration

To close the "Zero Calibration " or cancel this mode midway, press the **ESC** key. A previous screen will return.

ZERO Cal.	ENT : Go on calibration ESC : Not calibration	
H ₂	Range1 ▶ 0-3 vol%	▶ 1.28
	Range2 0-10 vol%	

6.7.2 Span calibration

It is used to perform a span point adjustment. Supply calibration gas with concentration set to the span value to perform the span calibration. Use the standard gas with a concentration of 90% or more of the range value.

- (1) Press the **SPAN** key on the measurement screen to display the Span Calibration screen.

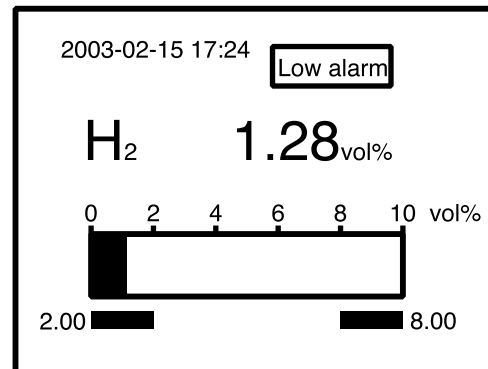

- (2) Pressing, the **ENT** key turns ON the contact for span calibration.

Caution

If "Both" has been selected for "Calibration range action", calibration is carried out in both ranges simultaneously.

SPAN Cal.		ENT : Gas flows ESC : Back	
▶ H ₂	Range1 ▶	0-3 vol%	1.28
	Range2	0-10 vol%	

- (3) Wait until the indication is stabilized in the state where the calibration gas is supplied. After the indication has been stabilized, press the **ENT** key. Span calibration of range selected by the cursor is performed.

To close Span Calibration

To close the "Span Calibration" or cancel this mode midway, press the **ESC** key. A previous screen will return.

SPAN Cal.		ENT : Go on calibration ESC : Not calibration	
H ₂	Range1 ▶	0-3 vol%	▶ 1.28
	Range2	0-10 vol%	

7. MAINTENANCE

7.1 Daily check

(1) Zero calibration and span calibration

- ① It is used for zero point adjustment. For calibration, refer to 6.7.1, Zero calibration.
- ② After zero calibration, perform span calibration. For calibration, refer to 6.7.2, Span calibration.
- ③ Zero calibration and span calibration should be performed once a week, if required.

(2) Flow check

- ① Sampling gas flow rate and purge gas flow rate should be as follows;
 Sampling gas flow rate: 0.4L/min±0.05L/min (stable), 1L/min±0.05L/min (high speed response)
 Purge gas flow rate: About 1L/min
- ② Maintenance and check should be carried out every day, if required.

7.2 Daily check and maintenance procedures

Table 7-1 Maintenance and check list

	Parts to be checked	Phenomena	Cause	Remedy
Every day	Recorder indication	Lower indication	① Dust is mixed in the sample cell.	① Clean sampling cell and check for sampling device, especially gas filter.
			② Air is sucked in anywhere in the sampling tube.	② Check for leak of the sampling line and repair, if required.
	Check for purge gas flow if purging the sampling gas flow instrument.	Standard gas is not within the range of the specified flow rate of 0.45 to 0.35 L/min or 0.95 to 1.05 L/min (high speed response).	_____	Adjust the flow rate with flow rater needle valve.
	Replacement of membrane filter	Much clogged		① Replace primary filter. ② Replace filter.
Every week	Zero point of gas analyzer	Out of zero point	_____	Zero calibration
	Span point of gas analyzer	Out of the standard point	_____	Span calibration
	Replacement of membrane filter	Irrespective of phenomena	_____	Replace filter (paper).
Every year	Gas analyzer	Irrespective of phenomena	_____	Overhaul.
	Gas analyzer output	After overhaul.	_____	Instrumental error test

8. TROUBLESHOOTING

8.1 Error message

If errors occur, the following contents are displayed.

Error display	Error contents	Probable causes
Error No.4	Zero calibration is not within the allowable range.	<ul style="list-style-type: none"> • Zero gas is not supplied. • Detector is faulty.
Error No.5	A amount of zero calibration (indication value) is over 50% of full scale.	
Error No.6	Span calibration is not within the allowable range.	<ul style="list-style-type: none"> • Span gas is not supplied. • Calibrated concentration setting does not match cylinder concentration. • Zero calibration is not performed properly. • Detector sensitivity is deteriorated.
Error No.7	A amount of span calibration (difference between indication value and calibrated concentration value) is over 50% of full scale.	
Error No.8	Measured values fluctuate too much during zero and span calibration.	<ul style="list-style-type: none"> • Calibration gas is not supplied. • Time for supplying calibration gas is short.
Error No.9	Calibration is abnormal during auto calibration.	

Screen display and operation at the occurrence of error

Measurement screen

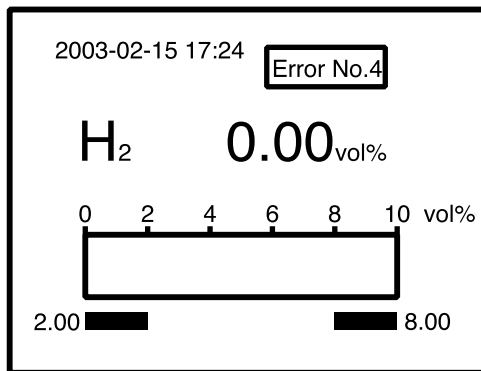

- Press the **ESC** key to delete the error display.
- If the **ESC** key is pressed without removing the cause of an error, the error will be displayed again.

Display of error contents

Error No.4	Out of ZERO Cal. range ESC : Back to MEAS.
H ₂ Calibration error Calibration is not successfully Cause <ul style="list-style-type: none"> • Zero gas is not flowing • Failure of detector 	

- When more than one error occurs, pressing the **▶** key moves to another error display.

Error log file

If an error occurs, it is recorded in the error log file. You can check the file by selecting **Error Log File** in maintenance mode screen.

Error log screen

Maintenance Error Log	ENT : Clear Error Log ESC : Back			
Errors that occurred	Error No. 4	WED	11 : 09 H2	Day of the week and time when an error occurred.
	Error No. 5	WED	11 : 09 H2	Component with which the error occurred.
	Error No. 4	WED	11 : 07 H2	
	Error No. 7	WED	10 : 58 H2	
	Error No. 6	WED	10 : 23 H2	
	Error No. 7	WED	10 : 23 H2	
	Error No. 7	WED	10 : 09 H2	
	▼Next page		page. 1	
	☐ Clear Error Log			

New
↓
Old

* Up to 14 errors can be saved in the error history. The oldest error will be deleted one by one every time a new occurs.

* If the power display supply is turned OFF, the contents in the error log file will not be lost or damaged.

Deletion of error history

Press the **ENT** key on the above screen, and the "Clear Error Log" will be inverted.

Further pressing the key will clear the error history.

9. SPECIFICATIONS

9.1 General Specifications

Standard Specifications

Measuring principle:
Measurement of thermal conductivity

Measurable component:
He, Ar, H₂, CH₄, CO₂

Measurable range:
Refer to Table 1

Output signal: 4 to 20 mA DC, 0 to 1 V DC, 0 to 10 mV DC
Non-isolated output
(Any one-output signal specifiable in CODE SYMBOLS)

Allowable load resistance:
550 Ω max. (in 4 to 20 mA DC output)

Output resistance:
100 kΩ (in 0 to 1 V DC or 0 to 10 mV DC output)

Display unit: LCD with backlight

Display of measured value:
Max. 4 digits

Display language:
English

Output signal holding:
In both manual and automatic calibrations, output value just before calibration can be held.

Power supply: 100 to 240 V AC, 50/60 Hz

Power consumption:
Approx. 50 VA

Warm-up time: At least 30 min

Ambient temperature:
-5 to 45°C

Ambient humidity:
Less than 90% RH (condensation unallowable)

Storage conditions:
-20 to 60°C, less than 95% RH (condensation unallowable)

Mounting: Flush mounting on panel

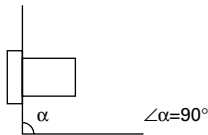

External dimensions (H x W x D):
240 x 192 x 213 mm

Mass: Approx. 5 kg

Finish color: Off-white (equivalent to 10Y7.5/0.5)

Housing: Steel-plate case, indoor use type

Material of gas-contacting parts:
JIS SUS304, platinum, platinum iridium, silver, fluororubber, epoxy resin, nickel, tin

Gas inlet/outlet, purge port:
Rc1/4 or NPT1/4 (whichever specified)

External connection terminal:
M3.5 screw terminal (9-pin D-sub connector for RS-232C)

Performance

Repeatability: ±1% of F.S.
Drift: Zero point :
within ±2% of full scale/week (H₂ meter, reference gas N₂)
Span : within ±2% of full scale/week (H₂ meter, reference gas N₂)

Response time (90% response):
High speed within 10 sec (at flow rate 1 L/min), allowed only for H₂ meter (reference gas N₂)
Standard within 60 sec (at flow rate 0.4L/min)

Other gases' interference:
Indication error of each measured value (vol%)

Interference component	H ₂ meter	CH ₄ meter	Ar meter	CO ₂ meter
H ₂ 1%	-	+5.8	-6.5	-8.0
CH ₄ 1%	+0.17	-	-1.15	-1.38
SO ₂ 1%	-0.31	-1.8	+2.1	+2.5
Ar 1%	-0.15	-0.87	-	+1.2
CO ₂ 1%	-0.125	-0.725	+0.83	-
O ₂ 1%	+0.019	+0.11	-0.125	-0.15
H ₂ O 1.5°C saturation	-	-	-	-0.56

Standard Gas Measurement Conditions

Temperature: 0 to 50°C

Gas flow rate: Constant at 0.4 ± 0.05 L/min
Constant at 1 ± 0.05 L/min (High speed response)

Dust: Less than 100 µg/Nm³ with a particle size of 0.3 µm max

Pressure: 10 kPa max

Mist: Unallowable

Moisture: Below saturation at 2°C

Corrosive gas: Unallowable

Standard gases for calibration:
Zero gas : Same as reference gas or as specified
Span gas : Concentration within 90 to 100% of measuring range
Concentration beyond 100% is inapplicable.

Installation Conditions

- The analyzer should not be exposed to direct sunlight or radiation from a hot object.
- A place subjected to heavy vibrations should be avoided. A location with clean atmosphere should be selected.
- Before measuring combustible gases, the existing gases should be purged from the analyzer using air or N₂.
- When the analyzer is installed outdoors, it should be sheltered with a housing or cover to protect it from rain and wind.

Optional Specifications

Linearization: Measured value output signal
Linearity within $\pm 2\%$ of F.S.

Relay contact output:

- 5 SPST relay contact outputs
- Relay contact capacity; 220 V AC/2 A (resistive load)
- Isolated with relay between contacts, and between contacts and internal circuit.
- Max. 5 points are selectable among those listed below.
- <1> Zero-side solenoid valve drive output for automatic calibration
- <2> Span-side solenoid valve drive output for automatic calibration
- <3> Suction pump OFF output in automatic calibration (reray "ON" immediately after turning on power supply)
- <4> Upper limit (1 point) concentration alarm output
- <5> Lower limit (1 point) concentration alarm output
- <6> Upper/Lower limit (1 point) concentration alarm output
- <7> Upper limit (1 point) and lower limit (1 point) concentration alarm output (Total 2 points)
- <8> High-high limit (1 point at each step) concentration alarm output (Total 2 points)
- <9> Low-low limit (1 point at each step) concentration alarm output (Total 2 points)
- <10> Analyzer error or automatic calibration error alarm output
- <11> Calibrating status output
- <12> Range information output (only with 2-range meter)

Contact input: 3 non-voltage contact inputs
ON; 0 V, OFF; 5 V DC, current at ON; 5 mA
Isolated with photo coupler between inputs and internal circuit. Not isolated between contact inputs.
The following actions can be input
<1> Remote holding of measured value output
<2> Remote range changeover (only with 2-range meter)
<3> Remote start of automatic calibration

Interference gas measured value input:

Analog input for H₂ meter interference correction (1 to 5 V DC, 1 range)
Either CO₂ or CH₄ component of an external gas analyzer is to be input.
Adjustment is required at Fuji Electric's factory.
Details of measurement gas will be checked when receiving an order.

Automatic calibration function:

Zero and span calibrations are automatically carried out at the predetermined intervals.
Calibration gases are flowed sequentially by driving the externally installed solenoid valves.

Communicating function:

RS-232C (9-pin D-sub output)
Half duplex, asynchronous
MODBUS™ protocol, communication speed 9600 bps
Contents of communication:
Reading/writing of measured concentration values and various set values, and output of device status
Remarks:
For connection in RS-485, RS-232C/RS-485 converter should be provided separately

Explanation of Functions

Output signal holding	When holding is set (user setting is turned ON), the latest measured value output just before output signal holding will be held during manual or automatic calibration, or by remote output holding input. In this status, indicated values will not be held.
Remote output holding input	Upon short-circuiting the remote output holding input terminal when holding is set (user setting is turned ON), the latest measured value output will be held. Holding continues while the contact input terminal is close-circuited. In this period, indicated values will not be held.
Remote range changeover input	When remote range setting is selected (user setting is turned ON) for two rang type, range will be changed over according to the external signal input (non-voltage contact) applied to the remote range changeover input terminal. In this mode, range cannot be changed manually. When close-circuiting the contact input terminal, the first range is selected, and the second range is selected at open circuit.
Range identification signal output	With two rang type, the current measuring range identification is output in contact signal. The contact output terminal is closed for the first range, and open for the second range.
Automatic calibration	<p>Zero and span calibrations are automatically carried out by outputting the signal for driving the externally installed solenoid valves for calibration gases at the set start time and interval or through input of the remote calibration start signal.</p> <ul style="list-style-type: none"> • Calibration channel: 1 component • Calibration accuracy: $\pm 0.2\%$ of F.S. • Zero calibration point settable range: 0 to 100% of F.S. • Span calibration point settable range: 1 to 100% of F.S. • Calibration interval settable range: 1 to 99 hours (1 hour step) or 1 to 40 days (1 day step) • Calibration gas injection time settable range: 60 to 599 sec (in sec) • Calibration start: Internal timer or remote calibration start input • Solenoid valve drive signal output: SPST contact (zero x 1, span x 1) • Suction pump OFF output in calibration: SPST contact (suction pump OFF x 1) • Remote calibration start input: No-voltage contact input <p>Automatic calibration is started by applying a non-voltage rectangular wave to the remote calibration start input terminal (opened after close-circuiting for 1.5 sec or longer). When contacts open, automatic calibration is carried out once.</p> <ul style="list-style-type: none"> • Automatic calibration error alarm output: SPST contact <p>Contacts close when the quantity of zero or span calibration exceeds 50% of full scale from the level of previous calibration, and contacts open when there is no abnormalities. When automatic calibration is abnormal, measurement output depends on the previous calibration values.</p> <ul style="list-style-type: none"> • Automatic calibration status output: SPST contact <p>During automatic calibration, contacts close, and open when within 50%.</p>
Upper/lower limit, upper limit and lower limit alarm output	Alarm contact output is issued with reference to the set upper/lower limit for alarm. Hysteresis is settable. When measuring value exceed alarm setting value, contacts close, and open when not exceeded. SPST contact
Analyzer error	When the analyzer or automatic calibration is abnormal, contacts close, and open when normal. SPST contact
Interference correction by interference gas measured value input	<p>Correction is made using either CO₂ or CH₄ component for H₂ measurement. Measured H₂ gas concentration is corrected in response to a concentration change of interference gas within its concentration range measured and set in advance.</p> <p>External interference gas measured value input : 1 to 5 V DC, 1range Interference gas fluctuation range : Reference concentration $\pm 20\%$ F.S. H₂ gas concentration correcting range : Reference concentration $\pm 25\%$ F.S. Correction accuracy : $\pm 5\%$ F.S.</p> <p>(Note 1) Correction accuracy value is larger when other interference gas is contained in the sample gas.</p>

Table 1: Measurable Component and Measurable Range

Measured gas	Reference gas component (Note 1)	Measurable range	Range ratio(Note 2)	Output signal characteristic without linearization (Note 3)
H ₂	N ₂ , (CO ₂ , Ar, He)	0 to 3, 5, 10, 20, 50, 80, 100% 100 to 90, 100 to 80%	1 : 10	100 to 90% : Linear Other : Nonlinear
He	N ₂ , (CO ₂ , Ar) O ₂ , Air	0 to 5, 10, 20, 30, 40, 50, 80, 100% 100 to 90, 100 to 80%	1 : 10	100 to 90% : Linear Other : Nonlinear
Ar	N ₂ , O ₂ , Air, (He)	0 to 10, 20, 50, 80, 100% 100 to 90, 100 to 80%	1 : 05	0 to 20%, 100 to 90% : Linear Other : Nonlinear
CH ₄	N ₂ , (CO ₂ , Ar, He)	0 to 20, 40, 50, 60, 80, 100% 100 to 80%	1 : 05	Nonlinear
CO ₂	N ₂ , O ₂ , Air, (He)	0 to 10, 20, 50, 100% 100 to 90, 80%	1 : 05	0 to 10, 20% : Linear Other : Nonlinear

(Note 1) The parenthesized gases require inquiry.

(Note 2) Range ratio stands for maximum value.

(Note 3) "Linear" indicates an accuracy within $\pm 2.5\%$ of full scale.

9.2 Code symbols

Digit	Description	ZAF	4	5	6	7	8	9	10	11	12	13	14
4	<Indication, response> Indication in English, standard response Indication in English, high-speed response		E	H									
5	<Measured component> H ₂ Ar He CH ₄ CO ₂ (reference gas Ar unallowable) Other		K	L	M	E	A	Z					
6	<Reference gas> (Note 1) N ₂ Air (incompatible with H ₂ /CH ₄ measurement) O ₂ (incompatible with H ₂ /CH ₄ measurement) Other				4	5	6	Z					
7	<Power supply, connection port size> AC100 to 240V 50/60Hz, Rc1/4 AC100 to 240V 50/60Hz, NPT1/4					0	1						
8	<Revision No.>						3						
9	<Measuring range (1st range)> 0 to 3% (H ₂) 0 to 5% (H ₂ , He) 0 to 10% (H ₂ , He, Ar, CO ₂) 0 to 20% 0 to 30% 0 to 50% 0 to 80% 0 to 100% 100 to 90% (H ₂ , He, Ar) 100 to 80% (H ₂ , He, Ar, CH ₄) Other							Q	L	M	N	V	P
10	<Measuring range (2nd range)> (Note 2) None 0 to 5% (H ₂ , He) 0 to 10% (H ₂ , He, Ar) 0 to 20% (H ₂ , He, Ar, CO ₂) 0 to 30% 0 to 50% 0 to 80% 0 to 100% Other								Y	L	M	N	V
11	<Measured value output> DC4 to 20 mA DC0 to 1V DC4 to 20 mA + RS-232C communication DC 0 to 1 V DC + RS-232C communication DC0 to 10mV									A	B	C	D
12	<Linearization> None Provided									Y	A		
13	<H ₂ meter interference corrective calculation> (Note 3) None Provided										Y	A	
14	<Input/output contacts> None Automatic calibration Automatic calibration Concentration alarm Concentration alarm Contact output selection Contact output selection See table below.												Y A B C D E F

(Note 1) Reference gas refers to gas other than the component to be measured in sample gas. ("Z" must be specified when interference gas is to be contained.)

(Note 2) The ratio of maximum range to the first range is as given below.
For CO₂, Ar or CH₄ measurement : 1st range x 5 (times)
For He or H₂ measurement : 1st range x 10 (times)
A range from 0 to ...% cannot be combined with that from 100 to ...%.

(Note 3) A CO₂ or CH₄ meter needs to be prepared separately.
A reverse range such as 100 to 0% cannot be specified.
Input signal is 1 to 5 V DC.
Adjustment is required at Fuji Electric's factory.
Details of measurement gas will be checked when receiving an order.
Cannot be selected when the measurement range is over 100%.

Input/output contact specifications		14th digit : A	14th digit : B	14th digit : C	14th digit : D	14th digit : E	14th digit : F
		Automatic calibration	Concentration alarm	Concentration alarm	Concentration alarm	Concentration alarm	Contact output selection (Note 7)
Contact output	Automatic calibration	○ (DO1) ○ (DO2) ● (DO3)	○ (DO1) ○ (DO2) ● (DO3)	— — —	— — —	○ ○ ●	○ ○ ●
	Concentration alarm	— — — — —	— — — — —	Any one alarm settable on screen (DO1, 2) 2 Point (NO) Contact	Any one alarm settable on screen (DO1, 2) 2 Point (NC) Contact	Any one alarm settable on screen (NO) Contact	Any one alarm settable on screen (NC) Contact
	Other	○ (DO4) — ○ (DO5)	● (DO4) — ● (DO5)	○ (DO4) ○ (DO3) ○ (DO5)	● (DO4) — ● (DO5)	○ — ○	● ○ ●
	Remote automatic calibration start (Note 4)	○ (DI3)	○ (DI3)	○ (DI3)	○ (DI3)	○ (DI3)	○ (DI3)
Remote range changeover (2-range meter) (Note 5)	○ (DI2)	○ (DI2)	○ (DI2)	○ (DI2)	○ (DI2)	○ (DI2)	
Remote measured value output holding (Note 6)	○ (DI1)	○ (DI1)	○ (DI1)	○ (DI1)	○ (DI1)	○ (DI1)	

(Note 1) Mark ○ : Normally Open (NO) contact
(Note 2) Mark ● : Normally Closed (NC) contact, after turning on power supply
(Note 3) Low range : Contacts close, High range : Contacts open
(Note 4) When contacts open 1.5 sec after their closure, automatic calibration starts.
(Note 5) Contacts closed : Low range, Contacts open : High range
(Note 6) Contacts closed : Holding, Contacts open : Holding canceled
(Note 7) Up to 5 contact outputs can be set.

9.3 Outline diagram (unit : mm)

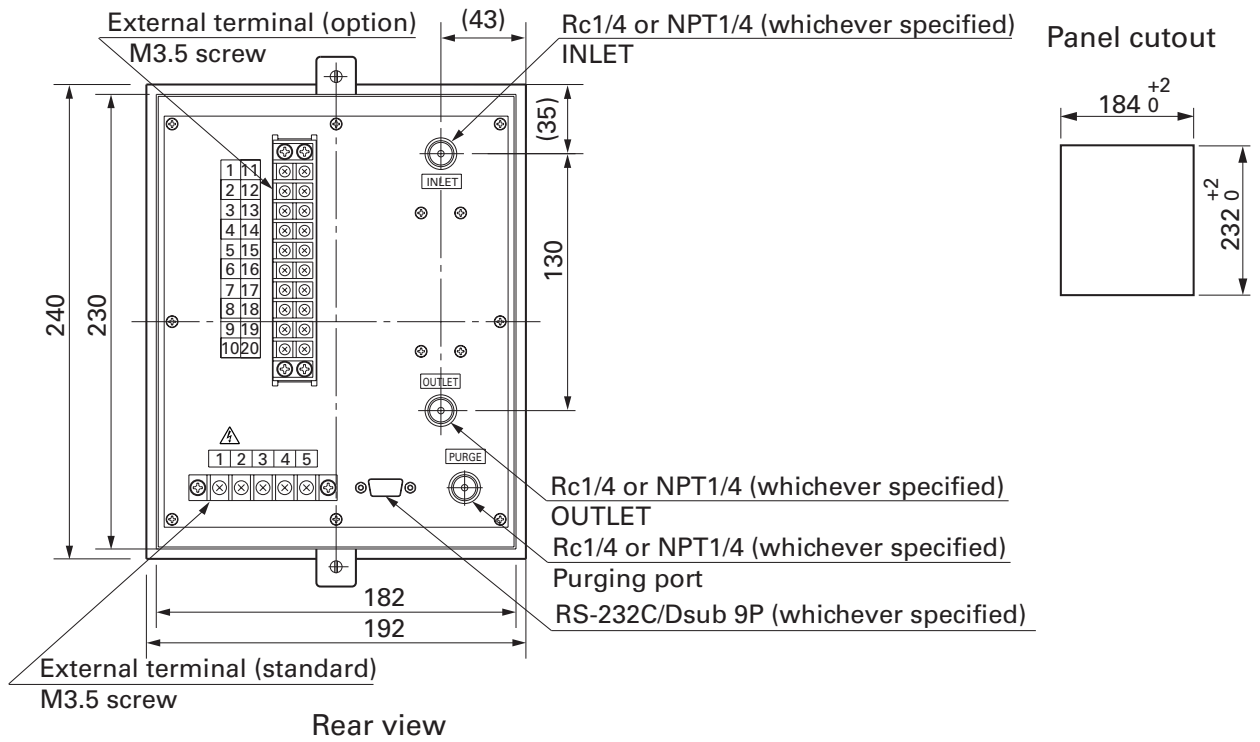
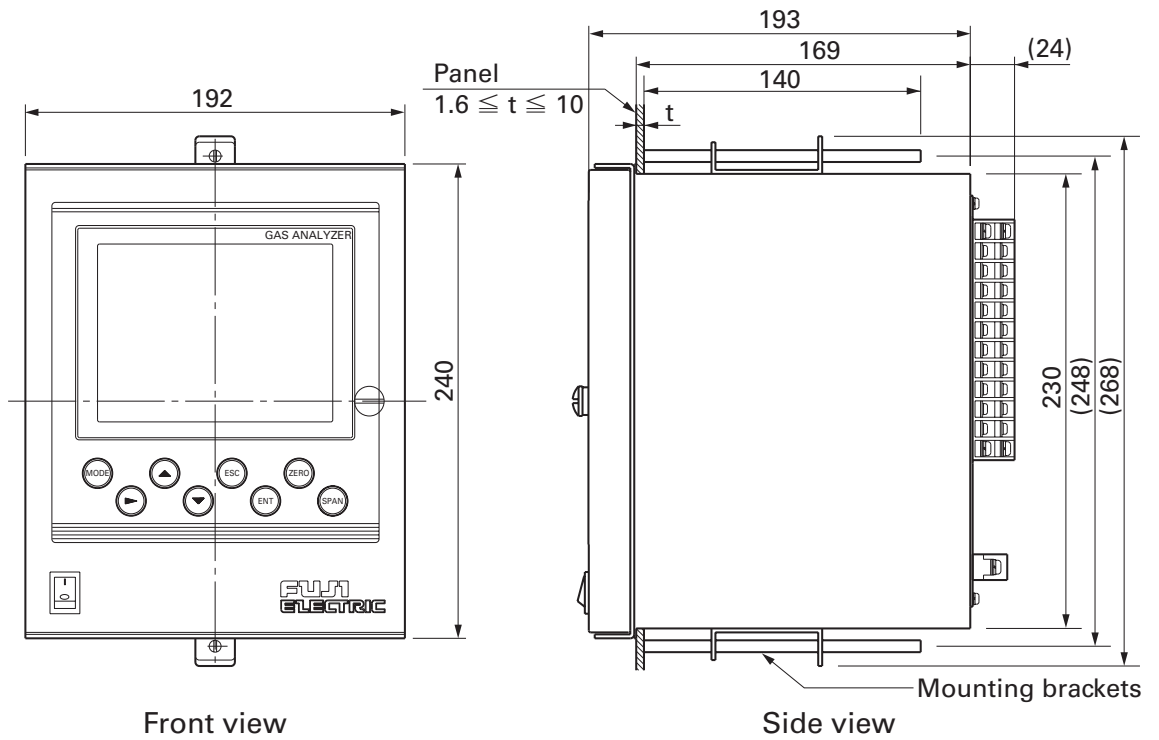

Fuji Electric Systems Co., Ltd.

Head Office

6-17, Sanbancho, Chiyoda-ku, Tokyo 102-0075, Japan
<http://www.fesys.co.jp/eng>

Sales Div.

International Sales Dept.

No.1, Fuji-machi, Hino-city, Tokyo 191-8502, Japan
Phone: 81-42-585-6201, 6202 Fax: 81-42-585-6187
<http://www.fic-net.jp/eng>
