



Instruction Manual

**ZIRCONIA OXYGEN
ANALYZER**

**TYPE: ZFK3
ZFK4
ZFK7**

PREFACE

We are grateful for your purchase of Fuji Electric's Zirconia Oxygen Analyzer (ZFK3, 4, 7).

- First read this instruction manual carefully until an adequate understanding is acquired, and then proceed to installation, operation and maintenance of the oxygen analyzer. Wrong handling may cause an accident or injury.
- The specifications of this oxygen analyzer will be changed without prior notice for further product improvement.
- Modification of this oxygen analyzer is strictly prohibited unless a written approval is obtained from the manufacturer. Fuji Electric will not bear any responsibility for a trouble caused by such a modification.
- This instruction manual shall be stored by the person who actually uses the oxygen analyzer.
- After reading the manual, be sure to store it at a place easier to access.
- This instruction manual should be delivered to the end user without fail.

Manufacturer: Fuji Electric Instrumentation Co., Ltd.
Type: Described in Fuji Electric's company nameplate on main frame
Date of manufacture: Described in Fuji Electric's company nameplate on main frame
Product nationality: Japan

Delivered items:

| | |
|---------------------------------|-------|
| Analyzer | 1 set |
| Power fuse 250V AC/3.15A) | 2 pcs |
| Instruction manual | 1 |

Request

- It is prohibited to transfer part or all of this manual without Fuji Electric's permission in written format.
- Description in this manual will be changed without prior notice for further improvement.



© Fuji Electric Systems Co., Ltd. 2006



Issued in February, 2006

CAUTION ON SAFETY

First of all, read this “Caution on safety” carefully, and then use the analyzer in the correct way.

- The cautionary descriptions listed here contain important information about safety, so they should always be observed. Those safety precautions are ranked in 3 levels; DANGER, CAUTION and PROHIBITION.

| | |
|--|---|
|  DANGER | Wrong handling may cause a dangerous situation, in which there is a risk of death or heavy injury. |
|  CAUTION | Wrong handling may invite a dangerous situation, in which there is a possibility of medium-level trouble or slight injury or only physical damage is predictable. |
|  PROHIBITION | Items which must not be done are noted. |

| Caution on installation and wiring of oxygen analyzer | |
|--|---|
|  DANGER | <ul style="list-style-type: none"> This unit is not explosion-proof type. Do not use it in a place with explosive gases to prevent explosion, fire or other serious accidents. |
|  CAUTION | <ul style="list-style-type: none"> This unit should be installed in a place which conforms to the conditions noted in the instruction manual. Otherwise, it may cause electric shocks, fire or malfunction of the unit. During installation work, care should be taken to keep the unit free from entry of cable chips or other foreign objects. Otherwise, it may cause fire, trouble or malfunction of the unit. The unit must be earthed as specified. Otherwise, it may cause electric shocks, malfunction, etc. Be sure to use a power supply of correct rating. Connection of power supply of incorrect rating may cause fire. Wiring work must be performed with all the power supplies to OFF to prevent electric shocks. Use wiring materials that match the rating of the unit. Use of wiring materials out of rating may cause fire. |
|  PROHIBITION | <ul style="list-style-type: none"> Wiring at a place which is exposed to water or rain, is prohibited in order to prevent electrical shock or damage to the instrument. |

Caution on operation, maintenance and check

 **DANGER**

- When noxious gases such as CO or other gases are contained in the calibration gas, be careful when venting or handling the instrument to avoid poisoning.

 **CAUTION**

- To avoid electrical shock, be sure to turn OFF the source power supply before work.
- To prevent burning your hands, be sure to turn OFF the source power supply before cleaning the piping outlet. After power off, wait until the piping outlet cools down.
- Do not use replacement parts other than those specified by the maker. Otherwise intended performance may not be obtained, or accidents or faults may result.
- Replacement parts such as a maintenance part should be disposed of as incombustibles.

 **PROHIBITION**

- Wiring at a place which is exposed to water or rain, is prohibited in order to prevent electrical shock or damage to the instrument.

Others

 **DANGER**

- When combustible gases are contained in measuring gas, check the gas composition and instrument specifications before use, or else the best performance may not be obtained or there may be a danger of explosion.

 **CAUTION**

- If the cause of any fault cannot be determined despite reference to the instruction manual, be sure to contact your dealer or Fuji Electric's technician in charge of adjustment. If the instrument is disassembled carelessly, you may have a shock hazard or injury.
- Do not use a replacement part other than specified by the instrument maker. Otherwise, adequate performance will not be provided. Besides, an accident or fault may be caused.

CONTENTS

| | |
|---|----|
| PREFACE | i |
| CAUTION ON SAFETY | ii |
| 1. OUTLINE | 1 |
| 2. NAME AND DESCRIPTION OF EACH PART | 2 |
| 2.1 Name and description of each part on case | 2 |
| 2.2 Name and description of internal parts | 3 |
| 3. INSTALLATION | 4 |
| 3.1 Mounting method | 4 |
| 3.2 Piping | 5 |
| 3.3 Sampling | 6 |
| 3.4 Wiring method | 7 |
| 4. OPERATING | 8 |
| 4.1 Operating procedure | 8 |
| 4.2 Preparation for operation | 8 |
| 4.3 Start of measurement | 8 |
| 4.4 Shutdown | 8 |
| 5. MAINTENANCE | 9 |
| 5.1 Daily inspection | 9 |
| 5.2 Cleaning gas outlet | 9 |
| 5.3 Replacement of fuse | 10 |
| APPENDIX | 11 |
| 1. Specifications | 11 |

1. OUTLINE

The zirconia oxygen analyzer utilizes a solid electrolyte consisting mainly of zirconia (ZrO_2) which conducts only oxygen ions at a high temperature. It is an oxygen sensor which measures, based on the principle of an oxygen concentration cell, the electromotive force produced due to the difference in oxygen concentration between the measured gas and reference air. By combining this analyzer with a sampling system including an infrared gas analyzer, it can accurately measure oxygen concentration for a variety of applications including combustion equipment control, air separation plants and laboratory use.

2. NAME AND DESCRIPTION OF EACH PART

2.1 Name and description of each part on case

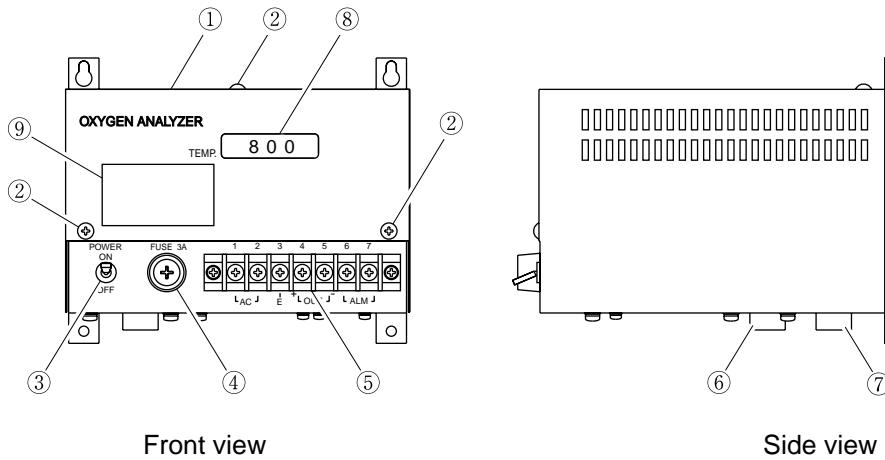

| No. | Name | Function |
|-----|-------------------------|---|
| 1 | Case cover | Protects the internal components. |
| 2 | Retaining screw | Fix the case cover. |
| 3 | Main switch | Turn ON to supply power to the interior. |
| 4 | Fuse | 250V AC/3.15A |
| 5 | Terminal board | Used to connect input/output |
| 6 | Sample gas inlet | Connect tube for gas to be measured. (Rc1/4 internal thread) |
| 7 | Sample gas outlet | Connect tube for discharging measured gas. (Rc1/4 internal thread) |
| 8 | Temperature indicator | Indicates the sensor temperature. |
| 9 | Specification nameplate | Indicates type and specifications. |

2.2 Name and description of internal parts

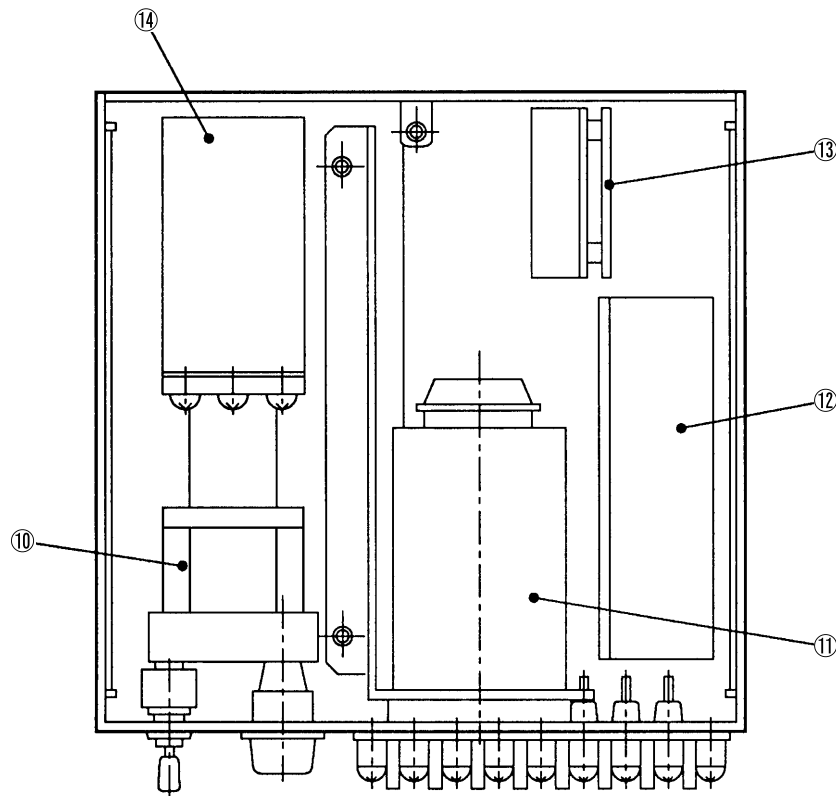

| No. | Name | Function |
|-----|------------------------|--|
| 10 | Oxygen sensor | Provides output according to oxygen concentration in sample gas. |
| 11 | Temperature controller | Controls heater of oxygen sensor at operating temperature of 800°C |
| 12 | DC power supply | Supplies +12V DC to amplifier PCB. |
| 13 | Amplifier PCB | Provides DC output of about 0 to 1V versus oxygen concentration of 20.6 to 0.05% O ₂ (ZFK: direct output from detector) |
| 14 | Gas feeding case | Introduces gas to be measured to the oxygen sensor. |

3. INSTALLATION

⚠ DANGER

- This unit is not explosion-proof type. Do not use it in a place with explosive gases to prevent explosion, fire or other serious accidents.

⚠ CAUTION

- This unit should be installed in a place which conforms to the conditions noted in the instruction manual. Otherwise, it may cause electric shocks, fire or malfunction of the unit.

3.1 Mounting method

(Unit: mm)

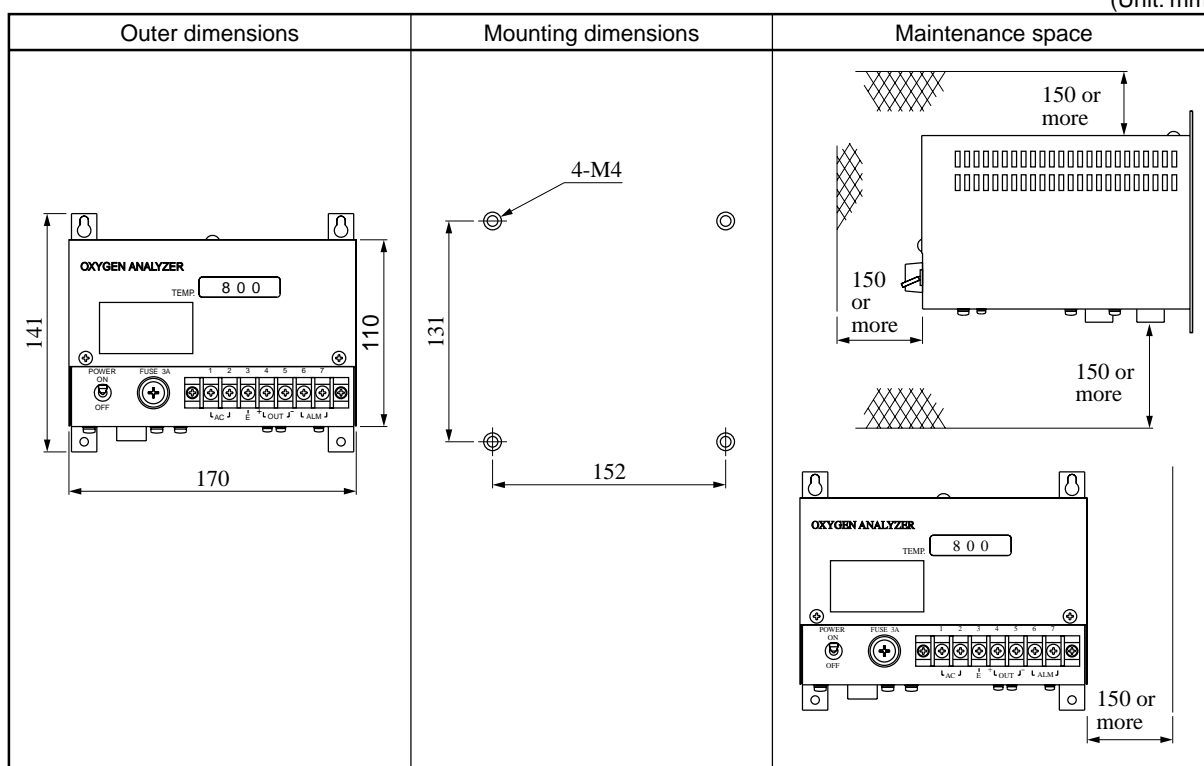

- Mount the unit on a metal plate, such as steel plate, of more than 3 mm thick using M4 screws or bolts. Do not mount it on materials such as plasterboard or lumber, which do not have sufficient strength for mounting. If the unit is to be mounted on a metal plate of less than 3 mm thick, it is recommended to fix the unit using nuts.
- Mount on a vertical wall with the gas inlet and outlet facing down.
- Provide space for maintenance and heat dissipation at the top, bottom, front and right side.
- To protect the oxygen sensor, avoid supplying power with the front of the unit facing upward.
- Select a proper installation location.
- Select a place where temperature will not fluctuate too much, and remains near the normal temperature and humidity.
- Select a place which is free from heat radiation or direct sunlight.
- This analyzer is of an indoor structure. When installing outdoors, select a place which is not exposed to rain or water or use a protective cover.
- Select a clean place which is free from corrosive gas or combustible gas.

3.2 Piping

(1) Piping method

Connect pipes to the gas inlet and outlet at the bottom of the unit.

Use anticorrosive tubes such as Teflon, stainless steel or polyethylene for connecting this instrument and the sampling system.

The inlet pipe should be kept as short as possible to allow a fast response. A suitable inner diameter is around 4mm. The pipes and joints should be clean, because dust entering the instrument may cause faulty operation.

Since sulfuric acid mist or oxides may be discharged through the outlet pipe, this pipe should have an inner diameter of about 8mm and be easily detachable for cleaning. A branch should also be provided midway on this pipe for eliminating mist and the like. The outlet pipe should be open to the atmosphere to avoid connecting it to another analyzer, sampling device, etc.

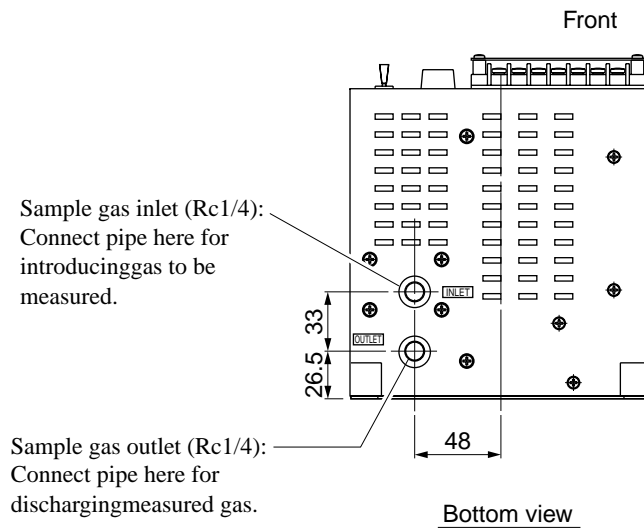

(2) Piping configuration diagram

Following is a typical example of piping.

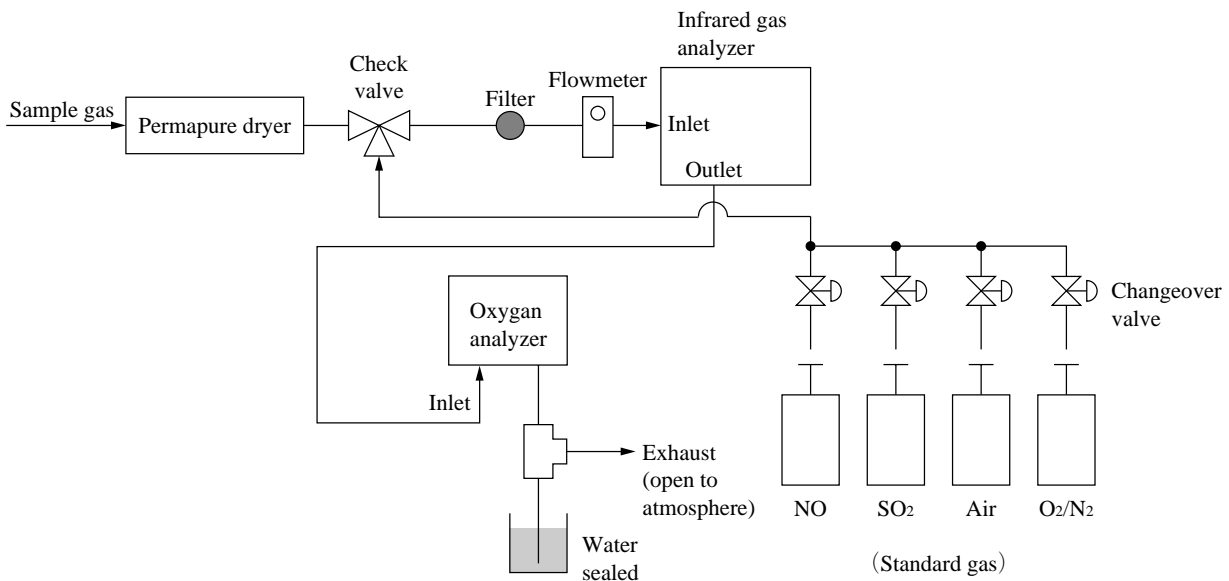

3.3 Sampling

⚠ DANGER

- This unit is not explosion-proof type. Do not use it in a place with explosive gases to prevent explosion, fire or other serious accidents.
- When combustible gases are contained in measuring gas, check the gas composition and instrument specifications before use, or else the best performance may not be obtained or there may be a danger of explosion.

3.3.1 Sample gas conditions

- (a) Dust included in sample gas should be completely eliminated with a filter. Use a filter capable of eliminating dust particles of 0.3 μ m at the final stage.
- (b) The dew point of sample gas must be lower than the ambient temperature to avoid condensation of drain inside the analyzer. If water vapor is included in sample gas, then use a dehumidifier to lower the dew point to about 0°C.
- (c) If SO₃ mist is included in sample gas, then use a mist filter, cooler or the like to exclude it. Other types of mist should also be excluded.
- (d) Strongly corrosive gases like Cl₂, F₂ and HCl included in sample gas will shorten the service life of the instrument. Harmful components such as Si vapor, alkaline metals, P, Pb and SO₂ at high concentrations (1000ppm or more) will also shorten its service life.
- (e) Sample gas temperature should range from 0 to 50°C. Do not introduce a high temperature gas directly into the instrument.
- (f) Combustible gases such as H₂ and CO included in sample gas will consume O₂ via a reaction and produce a measuring error.

3.3.2 Sample gas flow rate

Set the sample gas flow rate at 0.5 ± 0.25 L/min.

3.3.3 Preparation of standard gas

Prepare standard gas for zero point and span calibration.

| | | |
|--|--|---|
| Zero gas (span gas in rule of measuring) | Air | * |
| Span gas (zero gas in rule of measuring) | 1 to 2% O ₂ /N ₂ | |

* When using with O₂ range of 0 to 10%, the standard gas of 9 to 10% O₂/N₂ can also be used as zero gas (span gas in rule of measuring).

3.4 Wiring method

⚠ DANGER

- Wiring work must be performed with all the power supplies to OFF to prevent electric shocks.
- Be sure to perform class D grounding. Otherwise electric shock or malfunction may result.
- During installation work, care should be taken to keep the unit free from entry of cable chips or other foreign objects. Otherwise, it may cause fire, trouble or malfunction of the unit.
- Use wiring materials that match the rating of the unit. Use of the wiring materials out of rating may cause electric shocks or fire.
- Be sure to use a power supply of correct rating. Connection of power supply of incorrect rating may cause fire.

⊘ PROHIBITION

- Wiring at a place which is exposed to water or rain, is prohibited in order to prevent electrical shock or damage to the instrument.

External terminals are provided on the front of the instrument. Make connection to these terminals according to Fig. 3-1. Be sure to perform class D grounding.

Terminal screws are M4. Keep the power supply wiring to 3 m or shorter, and use a polyvinyl chloride wire of 1.25 sq for 600V or equivalent.

Use shielded wiring for the output signal to reduce the influence of external noise.

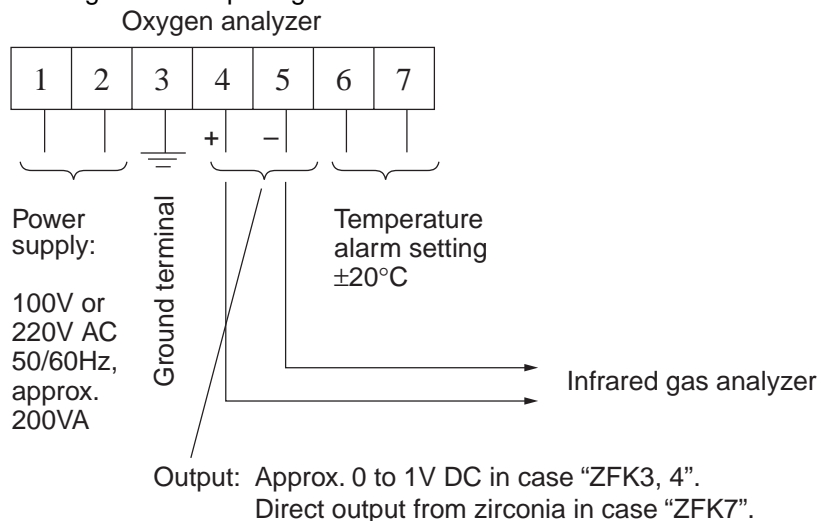

Fig. 3-1 External wiring

4. OPERATING

DANGER

- When noxious gases such as CO or other gases are contained in the calibration gas, be careful when venting or handling the instrument to avoid poisoning.
- When combustible gases are contained in measuring gas, check the gas composition and instrument specifications before use, or else the best performance may not be obtained or there may be a danger of explosion.

CAUTION

- Do not use a replacement part other than specified by the instrument maker. Otherwise, adequate performance will not be provided. Besides, an accident or fault may be caused.

PROHIBITION

- Wiring at a place which is exposed to water or rain, is prohibited in order to prevent electrical shock or damage to the instrument.

4.1 Operating procedure

Read through the instruction manual for the infrared gas analyzer to be combined with this analyzer, then proceed to operation accordingly.

The oxygen analyzer requires a warmup of at least 30 minutes.

4.2 Preparation for operation

(1) Check of piping and wiring

Make sure all the piping and wiring have been made correctly.

(2) Turning on power

Turn on the power switch and the temperature will be indicated.

(3) Warmup

Flow zero gas (air) and warm up the instrument for at least 30 minutes. The warmup is finished when the temperature reaches $800\pm 5^{\circ}\text{C}$.

(4) Calibration

Calibrate the zero point (air) and span with reference to the instruction manual for the infrared gas analyzer.

4.3 Start of measurement

Flow the sample gas into the instrument.

4.4 Shutdown

When shutting down the instrument, supply air or the like for at least 5 minutes to replace the measured gas inside the sensor.

The turn OFF the power switch.

5. MAINTENANCE

DANGER

- When noxious gases such as CO or other gases are contained in the calibration gas, be careful when venting or handling the instrument to avoid poisoning.

CAUTION

- If the cause of any fault cannot be determined despite reference to the instruction manual, be sure to contact your dealer or Fuji Electric's technician in charge of adjustment. If the instrument is disassembled carelessly, you may have a shock hazard or injury.
- To avoid electrical shock, be sure to turn OFF the source power supply before work.
- To prevent burning your hands, be sure to turn OFF the source power supply before cleaning the piping outlet. After power off, wait until the piping outlet cools down.
- Do not use replacement parts other than those specified by the maker. Otherwise intended performance may not be obtained, or accidents or faults may result.
- Replacement parts such as a maintenance part should be disposed of as incombustibles.
- Do not use a replacement part other than specified by the instrument maker. Otherwise, adequate performance will not be provided. Besides, an accident or fault may be caused.

PROHIBITION

- Wiring at a place which is exposed to water or rain, is prohibited in order to prevent electrical shock or damage to the instrument.

5.1 Daily inspection

(1) Zero point (air) and span calibration

- ① Calibrate the zero point according to the instruction manual for the infrared gas analyzer.
- ② Calibrate the span following zero point calibration.
- ③ Zero point and span should be calibrated about once a week as required.

(2) Check of flow rate

Check once a day if sample gas flow rate is 0.5 ± 0.25 L/min.

(3) Check of analyzer output and temperature indication

(a) Oxygen analyzer output

If the response is delayed or the oxygen indication does not change, then check for disconnected piping or clogging of the outlet pipe, etc.

(b) Temperature indication

- Check if the temperature indication is in a range of $800 \pm 5^\circ\text{C}$.
- If the temperature indicator shows "UUUU", then wiring may be disconnected or a thermocouple may be broken.

Check for continuity between 3 and 4 of the oxygen sensor - it should be around 2Ω .

When disconnected, replace the oxygen detector.

5.2 Cleaning gas outlet

Sulfate mist or oxide may be precipitated at the pipe output, depending on the components of measuring gas. In this case, turn OFF the source power supply and let the pipe cool down before cleaning the pipe.

5.3 Replacement of fuse

CAUTION

- Be sure to find the cause of the blowout and take necessary measures before replacing the fuse.

- (1) Turn off the power switch.
- (2) The fuse is located at the lower left viewed from the front. Pull up the cap of the fuse holder while rotating it counterclockwise, and the cap and the fuse are detached.
- (3) Replace the fuse with a new one (Fuse: 250V AC / 3.15A delay type).
- (4) Then fasten the cap of the fuse holder.

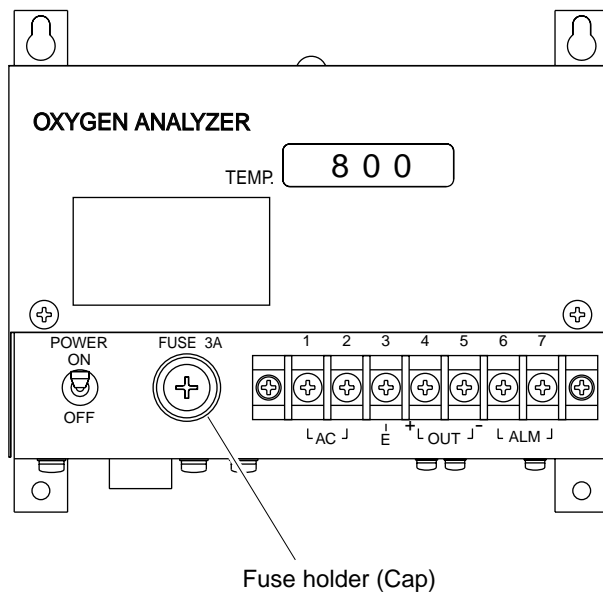

APPENDIX

1. Specifications

| | |
|---------------------------|--|
| Measuring system: | Zirconia solid electrolyte |
| Measuring range: | Minimum range 0 to 5 vol% O ₂ and maximum range of 0 to 25 vol% O ₂ , if used in combination with infrared gas analyzer |
| Measurable component: | Oxygen in noncombustible gas or combustion exhaust gas (sensor will be burned and error will appear if combustible gas is mixed in sample gas) |
| Output signal: | 4 to 20mA DC and 0 to 1V DC linear or direct output from sensor, connected to infrared gas analyzer |
| Sensor output: | Logical output of zirconia sensor (with sensor temperature of 800°C) $E = 50.74 \log \frac{20.6}{X} - B$ <p>E: Logical output (mV) X: Measured gas concentration (%O₂) B: Blank voltage (mV)</p> |
| Temperature alarm output: | Contact output normally-closed contact, contact capacity: 220V AC, 1A (resistive load) |
| Repeatability: | ±0.5% FS (when connected with infrared gas analyzer) |
| Flow rate: | 0.5±0.25 liter/minute (when connected with infrared gas analyzer) |
| Response speed: | Approx. 20 seconds for 90% response (when connected with infrared gas analyzer) |
| Warmup time: | Approx. 30 minutes |
| Ambient temperature: | 0 to +45°C |
| Ambient humidity: | 90% RH or less |
| Mounting method: | Indoor wall mounting |
| Gas inlet/outlet: | Rc1/4 (PT1/4 internal thread) |
| Outer dimensions (HxWxD): | 141x170x189.5mm |
| Mass: | Approx. 3kg |
| Finish color: | Munsell 5Y7/1 |

Code symbols:

As follows

| | | | | | | | | | | | | |
|---|---|---|---|---|---|---|---|---|----|----|----|----|
| 1 | 2 | 3 | 4 | 5 | 6 | 7 | 8 | 9 | 10 | 11 | 12 | 13 |
| Z | F | K | | Y | Y | | 4 | — | Y | 0 | Y | Y |

| | | | | | | | | Description | | | | |
|--|--|--|--|--|--|--|--|--|--|--|--|--|
| | | | | | | | | Measuring system, with or without certification* | | | | |
| | | | | | | | | Zirconia oxygen analyzer (without certification) | | | | |
| | | | | | | | | Zirconia oxygen analyzer (with a certification) | | | | |
| | | | | | | | | Zirconia oxygen analyzer (direct output from zirconia) | | | | |
| | | | | | | | | Power supply/Gas outlet | | | | |
| | | | | | | | | 90 to 126V AC, 50/60Hz | | | | |
| | | | | | | | | 200 to 240V AC, 50/60Hz | | | | |
| | | | | | | | | 200 to 240V AC, 50/60Hz (CE marking approved) | | | | |
| | | | | | | | | Standard gas outlet *1 | | | | |
| | | | | | | | | 200 to 240V AC, 50/60Hz (CE marking approved) | | | | |
| | | | | | | | | Expanded gas outlet *1 | | | | |
| | | | | | | | | Gas inlet/outlet | | | | |
| | | | | | | | | Rc1/4 | | | | |
| | | | | | | | | NPT1/4 | | | | |

*1: Selectable when 4th digit is 7.

Power supply

| | |
|----------------------|--|
| Rated voltage: | 100 to 115V AC or 200 to 240V AC |
| Rated frequency: | 50Hz/60Hz |
| Maximum rated power: | 215VA (at power on) / 65VA (during normal operation) |

Environmental condition

| | |
|--------------------------------------|-------------------|
| Use environment: | Indoors |
| Maximum altitude: | 2000 m |
| Fluctuation of power supply voltage: | 230V AC \pm 10% |
| Overvoltage category: | II |
| Pollution degree: | 2 |

Applicable standards

| | |
|----------------|-----------------------------------|
| Product safety | EN61010-1: 2001, IEC61010-1: 2001 |
|----------------|-----------------------------------|

Fuji Electric Systems Co., Ltd.

Head Office

Gate City Ohsaki, East Tower, 11-2, Osaki 1-chome,
Shinagawa-ku, Tokyo 141-0032, Japan
<http://www.fesys.co.jp/eng>

Instrumentation Div.

International Sales Dept.

No.1, Fuji-machi, Hino-city, Tokyo 191-8502, Japan
Phone: 81-42-585-6201, 6202 Fax: 81-42-585-6187
<http://www.fic-net.jp/eng>
