



Instruction Manual

**THERMAL CONDUCTIVITY
GAS ANALYZER
COMMUNICATION
FUNCTIONS (MODBUS)**

TYPE : ZAF

CONTENTS

1.	COMMUNICATION FUNCTIONS	1
1.1	General.....	1
2.	SPECIFICATIONS	2
2.1	Communication specifications.....	2
3.	CONNECTION	3
3.1	Terminal allocation (Input/output terminal CN2)	3
3.2	Connection	3
4.	SETTING OF COMMUNICATION CONDITION	4
4.1	Set items.....	4
4.2	Setting operation	4
5.	MODBUS COMMUNICATION PROTOCOL.....	5
5.1	General.....	5
5.2	Composition of message	6
5.3	Response of slave station	8
5.4	Function code.....	9
5.5	Calculation of error check code (CRC-16)	10
5.6	Transmission control procedure.....	12
6.	DETAILS OF MESSAGE	14
6.1	Read-out of word data [Function code:03 _H]	14
6.2	Read-out of read only word data [Function code:04 _H]	16
6.3	Write-in of word data (1 word) [Function code:06 _H].....	18
6.4	Write-in of continuous word data [Function code:10 _H]	19
7.	ADDRESS MAP AND DATA FORMAT	21
7.1	Data format	21
7.2	Address map	23
7.3	Supplement to address map	27
8.	SAMPLE PROGRAM	28
9.	TROUBLESHOOTING	34

1. COMMUNICATION FUNCTIONS

1.1 General

- This instrument provides a communication function through RS-232 interface, which allows data transmit to or receive from the host computer and other devices.
- The communication system is comprised of a master station and slave stations. One slave station (this instrument) can be connected to one master station.
It is also possible to adapt the instrument to the environment of RS-485 interface using RS-232 ↔ RS-485 converter. In this case, up to 31 of slave station (present instrument) can be connected per master station.
- Because the master station can communicate with only one slave station at a time, the destination can be identified by the "Station No" set for each slave station.
- In order that the master station and the slave station can communicate, the format of the transmit/receive data must coincide. In this instrument, the format of the communication data is determined by the MODBUS protocol.

[RS-232 ↔ RS-485 converter] (recommended article)

Type: KS-485 (non-isolated type)/SYSTEM SACOM Corp.

Type: SI-30A (isolated type)/SEKISUI ELECTRONICS Co., Ltd.

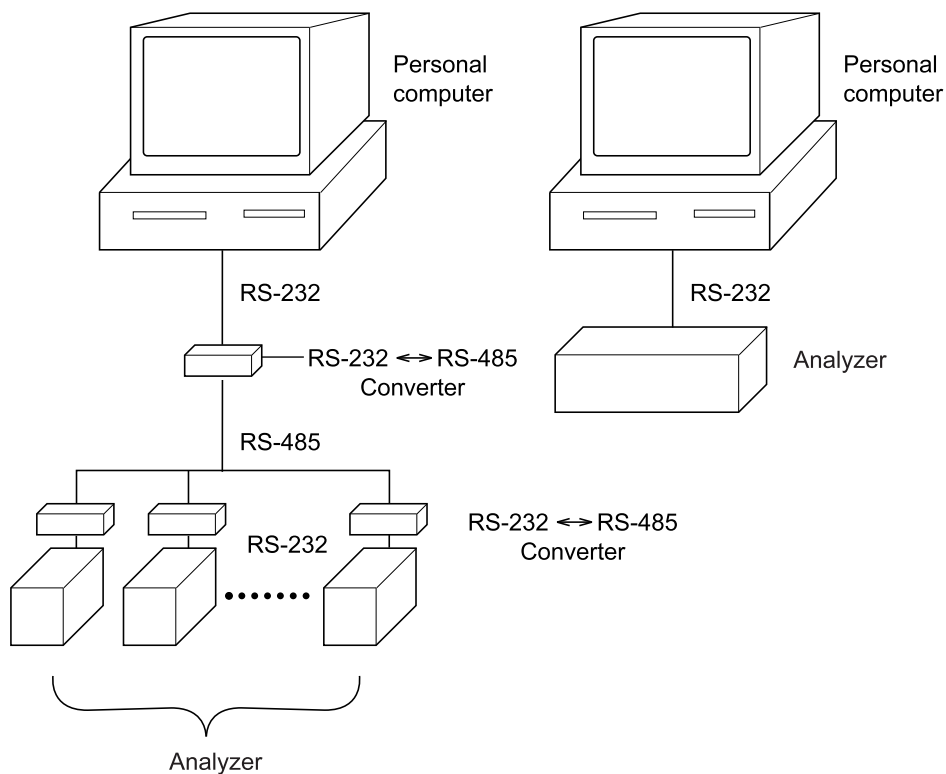

2. SPECIFICATIONS

2.1 Communication specifications

Item	Specification	
Electrical specification	Based on EIA RS-232	
Transmission system	2-wire, semi-duplicate	
Synchronizing system	Start-stop synchronous system	
Connection format	1 : 1	
Number connectable units	1 unit (or 31 if RS-485 interface is used)	
Transmission speed	9600bps	
Data format	Data length	8 bits
	Stop bit	1 bit
	Parity	None
	X flow control	None
Transmission code	HEX value (MODBUS RTU mode)	
Error detection	CRC-16	
Isolation	No isolation between transmission circuit and others	

3. CONNECTION

⚠ WARNING

For avoiding electric shock and malfunctions, do not turn on the power supply until all wiring have been completed.

3.1 Terminal allocation (Input/output terminal CN2)

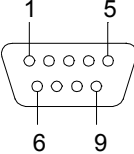
Terminal number	Signal name	Pin connection
2	Recive Data	 9-pin D-Sub (male)
3	Transmit Data	
5	Signal GND	
Others	NC	

3.2 Connection

As connecting cable, use a commercially available RS-232 reverse cable.

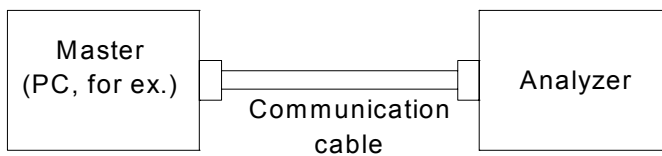

Connect the cable to CN2 on the input/output terminal block.

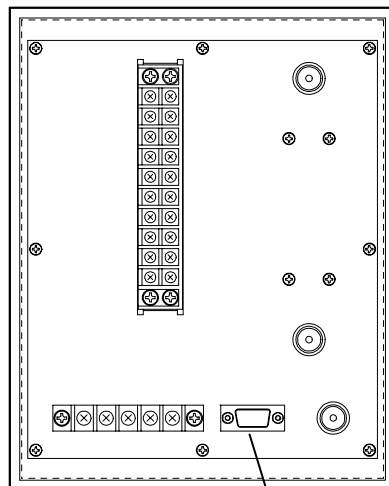

CN2 (communication connector)

4. SETTING OF COMMUNICATION CONDITION

In order that the master station and instrument can correctly communicate, following settings are required.

- All communication condition settings of the master station are the same as those of instruments.
- All instruments connected on a line are set to "Station Nos. (STno)" which are different from each other. (Any "Station No." is not shared by more than one instrument.)

4.1 Set items

The parameters to be set are shown in the following table. Set them by operating the front panel keys.

Item	Value at delivery	Setting range	Remarks
Transmission speed	9600bps	Fixed (can not be changed)	Set the same communication condition to the master station and all slave stations.
Data length	8 bits	Fixed (can not be changed)	
Stop bit	1 bit	Fixed (can not be changed)	
Parity setting	None	Fixed (can not be changed)	
Station No.	1	0 to 31 (0:communication function stop)	Set a different value to each station.

4.2 Setting operation

Set the station No. on the analyzer maintenance mode display (see the instruction manual).

5. MODBUS COMMUNICATION PROTOCOL

5.1 General

The communication system by the MODBUS protocol is that the communication is always started from the master station and a slave station responds to the received message.

Transmission procedures is as shown below.

- 1) The master station sends a command message to a slave station.
- 2) The slave station checks that the station No. in the received message matches with the own station No. or not.
- 3) If matched, the slave station executes the command and sends back the response message.
- 4) If mismatched, the slave station leaves the command message and wait for the next command message.

- a) In case when the station No. in the received command message matches with the own slave station No.

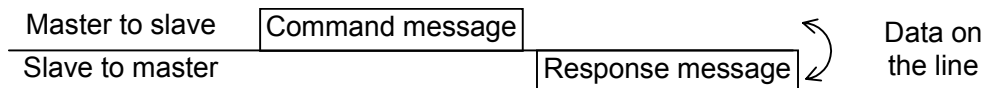

- b) In case when the station No. in the received command message mismatches with the own slave station No.

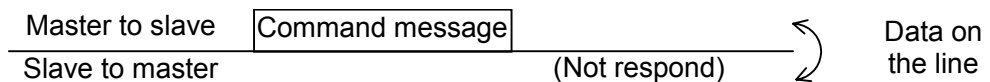

The master station can individually communicate with any one of slave stations connected on the same line upon setting the station No. in the command message.

5.2 Composition of message

Command message and response message consist of 4 fields ; Station No., Function code, Data and Error check code. And these are send in this order.

Station No. (1 byte)
Function code (1 byte)
Data (2 to 133 bytes)
Error check code (CRC-16) (2 bytes)

Fig. 5-1 Composition of message

In the following, each field is explained.

(1) Station No.

Station No. is the number specifying a slave station. Only a slave station that corresponds to a value to which "Station No." is set on the analyzer maintenance mode display executes a command.

(2) Function code

This is a code to designate the function executed at a slave station.
For details, refer to section 5.4.

(3) Data

Data are the data required for executing function codes. The composition of data varies with function codes. For details, refer to chapter 6.

A register number is assigned to each data in the analyzer. For reading/writing the data by communication, designate the register number.

Note that the register number transmitted on message is expressed as its relative address.
The relative address is calculated by the following expression.

$$\boxed{\text{Relative address}} = \left(\text{The lower 4 digits of the } \boxed{\text{Register number}} \right) - 1$$

For example, when the register number designated by a function code is 40003,

$$\begin{aligned} \text{Relative address} &= (\text{lower 4 digits of } 40003) - 1 \\ &= 0002 \end{aligned}$$

is used on the message.

(4) Error check code

This is the code to detect message errors (change in bit) in the signal transmission.

On the MODBUS protocol (RTU mode), CRC-16 (Cyclic Redundancy Check) is applied.

For CRC calculation method, refer to section 5.5.

5.3 Response of slave station

(1) Response for normal command

To a relevant message, the slave station creates and sends back a response message which corresponds to the command message. The composition of message in this case is the same as in section 5.2.

Contents of the data field depend on the function code. For details, refer to Chapter 6.

(2) Response for abnormal command

If contents of a command message have an abnormality (for example, non-actual function code is designated) other than transmission error, the slave station does not execute that command but creates and sends back a response message at error detection.

The composition of response message at error detection is as shown in Fig. 5-2. The value used for function code field is function code of command message plus 80_H.

Table 5-1 gives error codes.

Station No.
Function code + 80 _H
Error code
Error check (CRC-16)

Fig. 5-2 Response message at error detection

Table 5-1 Error code

Error code	Contents	Description
01H	Illegal function	Non-actual function code is designated. Check for the function code.
02H	Illegal data address	A relative address of a register number to which the designated function code can not be used.
03H	Illegal data value	Because the designation of number is too much, the area where register numbers do not exist is designated.

(3) No response

Under any of the following items, the slave station takes no action of the command message and sends back no response.

- A station number transmitted in the command message differs from the station number specified to the slave station.
- A error check code is not matched, or a transmission error (parity error, etc.) is detected.
- The time interval between the composition data of the message becomes longer than the time corresponding to 24 bits. (Refer to section 5.6 Transmission control procedure)

5.4 Function code

According to MODBUS protocol, register numbers are assigned by function codes.
Each function code acts on specific register number.

This correspondence is shown in Table 5-2, and the message length by function is shown in Table 5-3.

Table 5-2 Correspondence between function codes and objective address

Function code			Resister No.	
No.	Function	Object	No.	Contents
03 _H	Read-out (continuously)	Holding register	4xxxx	Read-out/write-in word data
04 _H	Read-out (continuously)	Input register	3xxxx	Read-out word data
06 _H	Write-in	Holding register	4xxxx	Read-out/write-in word data
10 _H	Write-in (continuously)	Holding register	4xxxx	Read-out/write-in word data

Table 5-3 Function code and message length

[Unit : byte]

Function code	Contents	Number of designatable data	Command message		Response message	
			Minimum	Maximum	Minimum	Maximum
03 _H	Read-out of word data	60 words	8	8	7	133
04 _H	Read-out of word data (read-out only)	15 words	8	8	7	133
06 _H	Write-in of word data	1 word	8	8	8	8
10 _H	Write-in of continuous word data	60 words	11	137	8	8

5.5 Calculation of error check code (CRC-16)

CRC-16 is the 2-byte (16-bits) error check code. From the top of the message (station No.) to the end of the data field are calculated.

The slave station calculates the CRC of the received message, and does not respond if the calculated CRC is different from the contents of the received CRC code.

The following shows the calculation procedure for CRC-16.

- (a) Store FFFF_H into 16 bit register (CRC register).
- (b) Subject the 1st byte (8 bits) of transmit message and CRC register contents to an exclusive logical summation (XOR), and store the result into the CRC register.
- (c) Shift the CRC register contents 1 bit to the right. Store 0 at MSB.
- (d) If LSB before shifting is 0, do nothing.
If LSB before shifting is 1, subject it and A001H to XOR, and store the result into the CRC register.
- (e) Repeat the steps (c) and (d) 8 times (shift by 8 bits).
- (f) Execute steps (b) to (e) for the next byte of the transmit message.
Likewise, successively repeat the steps to each byte of the transmit message.
- (g) The CRC code that is retained is the value of CRC register that stands when the processing has ended for latest byte (latest data except error code) of the transmit message.
- (h) As error check code of the transmit message, store this CRC value in the order of lower 8 bits and upper 8 bits.

Transmit message (ex.)

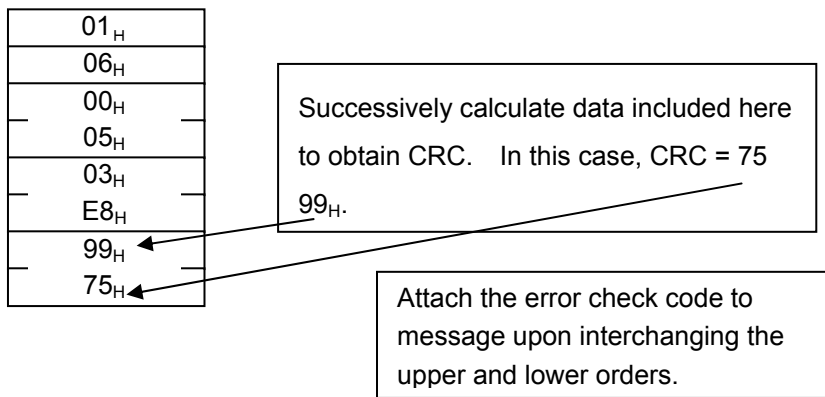

Fig. 5-3 shows the flow of the CRC-16 calculation system.

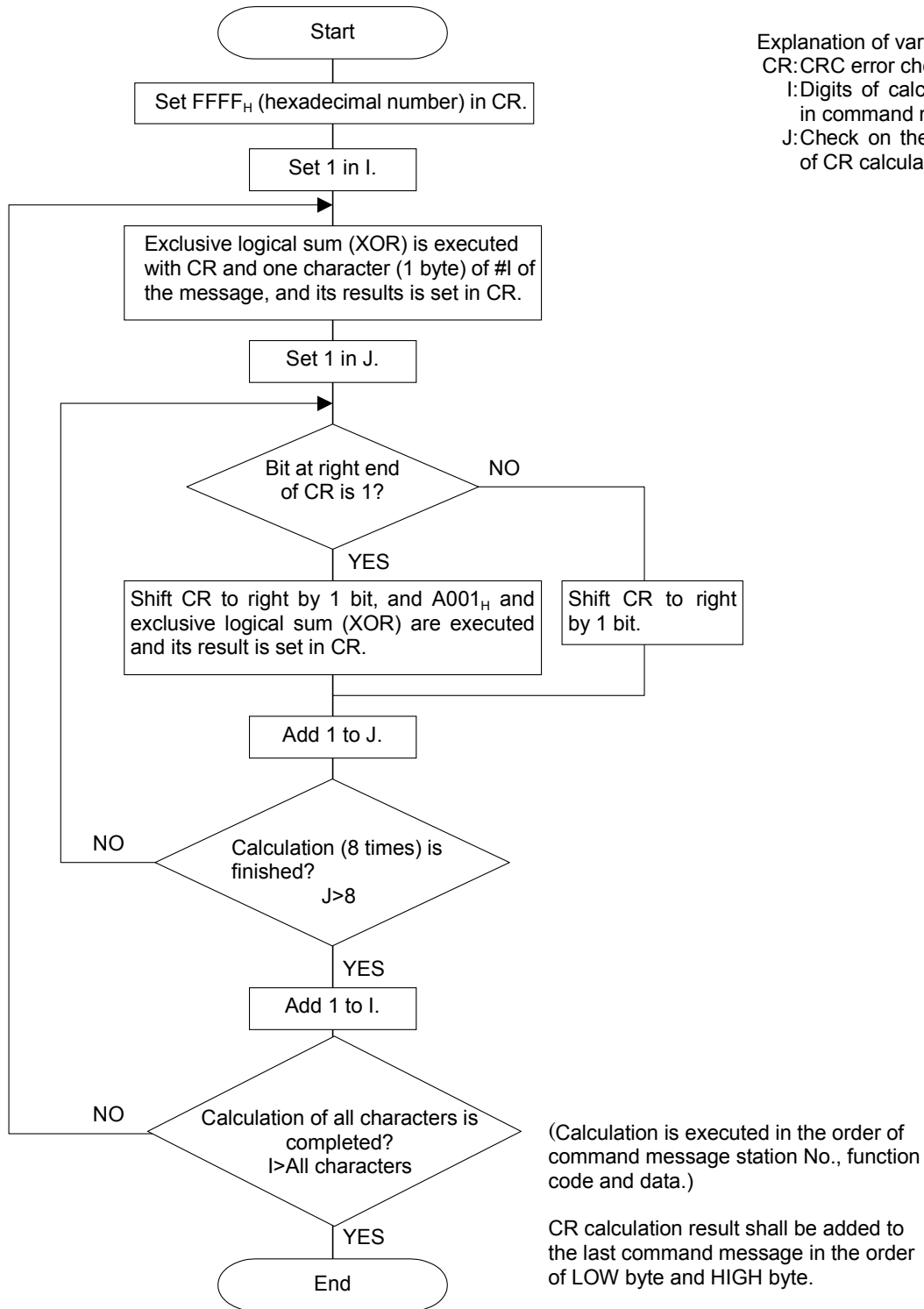

Fig. 5-3 Flow of CRC-16 calculation

5.6 Transmission control procedure

(1) Transmission procedure of master station

The master station must proceed to a communication upon conforming to the following items.

- (1-1) Before sending a command message, provide 48 bits time or more vacant status.
- (1-2) For sending, the interval between bytes of a command message is below 24 bits time.
- (1-3) Within 24 bits time after sending a command message, the receiving status is posted.
- (1-4) Provide 48 bits time or more vacant status between the end of response message reception and beginning of next command message sending [same as in (1-1)].
- (1-5) For ensuring the safety, make a confirmation of the response message and make an arrangement so as to provide 3 times or more retries in case of no response, error occurrence, etc.

Note) The above definition is for most unfavorable value. For ensuring the safety, it's recommended the program of the master to work with safety factors of 2 to 3. Concretely, it is advised to arrange the program for 9600 bps with 10 ms or more for vacant status (1-1), and within 1 ms for byte interval (1-2) and changeover from sending to receiving (1-3).

(2) Description

1) Detection of the message frame

The status on the line of the communication system is one of the 2 below.

- (a) Vacant status (no data on line)
- (b) Communication status (data is existing)

Instruments connected on the line are initially at a receiving status and monitoring the line. When 24 bits time or more vacant status has appeared on the line, the end of preceding frame is assumed and, within following 24 bits time, a receiving status is posted. When data appears on the line, instruments receive it while 24 bits time or more vacant status is detected again, and the end of that frame is assumed. I.e., data which appeared on the line from the first 24 bits time or more vacant status to the next 24 bits time or more vacant status is fetched as one frame.

Therefore, one frame (command message) must be sent upon confirming the following.

- (1-1) 48 bits time or more vacant status precedes before the command message sending.
- (1-2) Interval between bytes of 1 command message is smaller than 24 bits time.

2) Response of this instrument

After a frame detection (24 bits time or more vacant status), this instrument carries out processing with that frame as a command message. If the command message is destined to the own station, a response message is returned. Its processing time is 1 to 30 ms (depends on contents of command message). After sending a command message, therefore, the master station must observe the following.

- (1-3) Receiving status is posted within 24 bits time after sending a command message.

Space time of longer than 5ms is needed
(longer than 10ms is recommended)

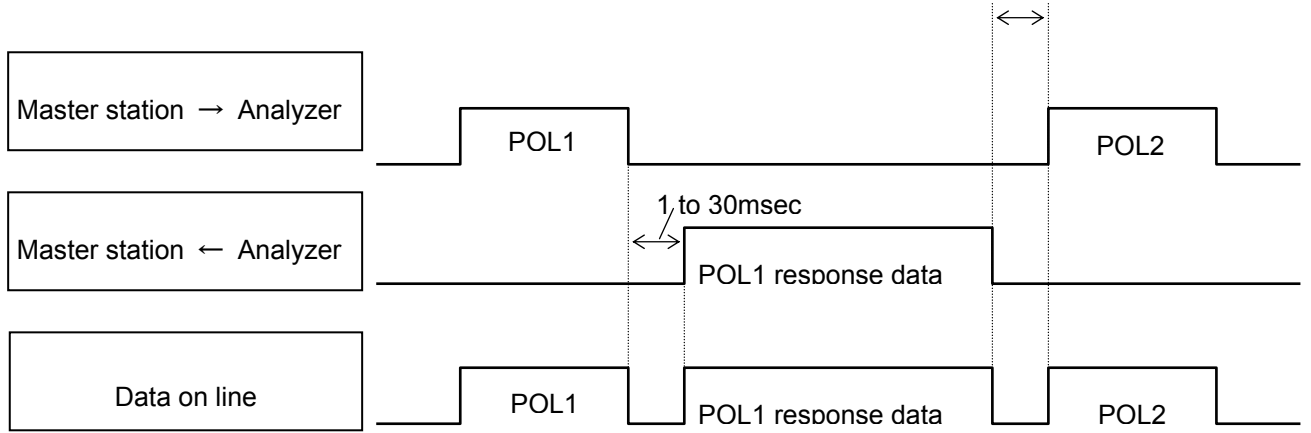

6. DETAILS OF MESSAGE

6.1 Read-out of word data [Function code:03_H]

Function code	Max. word number read-out in one message	Relative data address	Resister No.	Contents
03 _H	64 words	0000 _H —0023 _H	40001—40036	User setting

(1) Message composition

Command message composition (byte)

Station No.	
Function code	
Read-out start No. (relative address)	Upper
	Lower
Read-out word number	Upper
	Lower
CRC data	Lower
	Upper

} 1 to 64

Response message composition (byte)

Station No.		
Function code		
Read-out byte number		Read-out word number × 2
Contents of the first word data	Upper	
	Lower	
Contents of the next word data	Upper	
	Lower	
Contents of the last word data	Upper	
	Lower	
CRC data	Lower	
	Upper	

* Arrangement of read-out word data

MSB	LSB
Upper byte of contents of the first word data	
Lower byte of contents of the first word data	
Upper byte of contents of the next word data	
Lower byte of contents of the next word data	
Upper byte of contents of the last word data	
Lower byte of contents of the last word data	

(2) Function explanations

Word data of continuous word numbers from the read-out start No. can be read. Read-out word data are transmitted from the slave station in the order of upper and lower bytes.

(3) Message transmission (example)

The following shows an example of reading out from No. 1 station the setting range-1 zero and span calibration concentration.

Relative address of range-1 zero calibration concentration setting: 0000_H Data number: 02_H

Command message composition (byte)

Station No.	01 _H	
Function code	03 _H	
Read-out start No. (relative address)	Upper	00 _H
	Lower	00 _H
Read-out word number	Upper	00 _H
	Lower	02 _H
CRC data	Lower	C4 _H
	Upper	0B _H

Response message composition (byte)

Station No.	01 _H	
Function code	03 _H	
Read-out byte number	04 _H	
Contents of the first word data	Upper	00 _H
	Lower	00 _H
Contents of the next word data	Upper	0B _H
	Lower	B8 _H
CRC data	Lower	FD _H
	Upper	71 _H

* Meaning of read-out data

Range-1 zero calibration concentration setting 00 00_H = 0
(contents of first word data)

Range-1 span calibration concentration setting 0B B8_H = 3000
(contents of next word data)

Provided decimal point position = 3,

Set value lower limit = 0.0 vol%

Set value upper limit = 3.0 vol%



For handling of decimal point and unit, refer to Section 7.1.

6.2 Read-out of read only word data [Function code:04_H]

Function code	Max. word number read-out in one message	Relative data address	Resister No.	Contents
04 _H	64 words	0000 _H —0068 _H	30001—30105	Measurement value and status

(1) Message composition

Command message composition (byte)

Station No.	
Function code	
Read-out start No. (relative address)	Upper
	Lower
Read-out word number	Upper
	Lower
CRC data	Lower
	Upper

Response message composition (byte)

Station No.		Read-out word number × 2
Function code		
Read-out byte number		
Contents of the first word data	Upper	
	Lower	
Contents of the next word data	Upper	
	Lower	
—		
Contents of the last word data	Upper	
	Lower	
CRC data	Lower	
	Upper	

* Arrangement of read-out word data

MSB	LSB
Upper byte of contents of the first word data	
Lower byte of contents of the first word data	
Upper byte of contents of the next word data	
Lower byte of contents of the next word data	
—	
Upper byte of contents of the last word data	
Lower byte of contents of the last word data	

(2) Function explanations

Word data of continuous word numbers from the read-out start No. can be read. Read-out word data are transmitted from the slave station in the order of upper and lower bytes.

(3) Message transmission (example)

The following shows an example of reading out from No. 1 station the measurement concentration, decimal point position and measurement unit.

Relative address of measurement concentration: 0000_H Data number: 02_H

Command message composition (byte)

Station No.		01 _H
Function code		04 _H
Read-out start No. (relative address)	Upper	00 _H
	Lower	00 _H
Read-out word number	Upper	00 _H
	Lower	02 _H
CRC data	Lower	71 _H
	Upper	CB _H

Response message composition (byte)

Station No.		01 _H
Function code		04 _H
Read-out byte number		04 _H
Contents of the first word data	Upper	0A _H
	Lower	8D _H
Next word data contents	Upper	00 _H
	Lower	03 _H
CRC data	Lower	28 _H
	Upper	76 _H

* Meaning of read-out data

First word data contents 0A 8D_H = 2701

Next word data contents 00 03_H = 3 (decimal point position)

In the above case, measurement concentration = 2.701 vol%

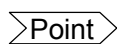

For handling of decimal point and unit, refer to Section 7.1.

6.3 Write-in of word data (1 word) [Function code:06_H]

Function code	Max. word number write-in in one message	Relative data address	Resister No.	Contents
06 _H	1 word	0000 _H –0023 _H	40001–40036	User setting
		07D0 _H –07D2 _H	42001–42003	Operation command

(1) Message composition

Command message composition (byte)

Station No.	
Function code	
Write-in designate No. (relative address)	Upper
	Lower
Write-in word data	Upper
	Lower
CRC data	Lower
	Upper

Response message composition (byte)

Station No.	
Function code	
Write-in designate No. (relative address)	Upper
	Lower
Write-in word data	Upper
	Lower
CRC data	Lower
	Upper

(2) Function explanation

Designated word data is written in write-in designate No. Write-in data are transmitted from master station in the order of upper and lower bytes.

(3) Message transmission (example)

The following shows an example of transmitting the "ZERO" key command to No. 1 station.
Key operation command Relative address: 07D0_H

Command message composition (byte)

Station No.		01 _H
Function code		06 _H
Write-in designate No. (relative address)	Upper	07 _H
	Lower	D0 _H
Write-in word data	Upper	00 _H
	Lower	02 _H
CRC data	Lower	08 _H
	Upper	86 _H

} ZERO key command

Response message composition (byte)

Station No.		01 _H
Function code		06 _H
Write-in designate No. (relative address)	Upper	07 _H
	Lower	D0 _H
Write-in word data	Upper	00 _H
	Lower	02 _H
CRC data	Lower	08 _H
	Upper	86 _H

6.4 Write-in of continuous word data [Function code:10_H]

Function code	Max. word number write-in in one message	Relative data address	Resister No.	Kind of data
10 _H	64 words	0000 _H —0023 _H	40001—40036	User setting

(1) Message composition

Command message composition (byte)

Station No.	
Function code	
Write-in start No. (relative address)	Upper
	Lower
Write-in word number	Upper
	Lower
Write-in byte number	
First write-in word data	Upper
	Lower
Next write-in word data	Upper
	Lower
Last write-in word data	Upper
	Lower
CRC data	Lower
	Upper

} 1 to 60

} Write-in word number × 2

Response message composition (byte)

Station No.	
Function code	
Write-in start No. (relative address)	Upper
	Lower
Write-in word number	Upper
	Lower
CRC data	Lower
	Upper

* Arrangement of write-in word data

MSB	LSB
Upper byte of contents of the first word data	
Lower byte of contents of the first word data	
Upper byte of contents of the next word data	
Lower byte of contents of the next word data	
Upper byte of contents of the last word data	
Lower byte of contents of the last word data	

(2) Function explanation

Word data of continuous word number is written from write-in start address. Write-in word data are transmitted from master station in the order of upper and lower bytes.

(3) Message transmission (example)

The following shows an example of writing the CH1 (1st component) alarm settings to No. 1 station.

Range1 alarm 1-step set value = 07D0_H (= 2000_D)

Range1 alarm 2-step set value = 03E8_H (= 1000_D)

Range2 alarm 1-step set value = 0384_H (= 900_D)

Range2 alarm 2-step set value = 0064_H (= 100_D)

Range1 alarm 1-step set value Relative address: 0023_H Data number: 04_H

Command message composition (byte)

Station No.		01 _H
Function code		10 _H
Write-in start No.	Upper	00 _H
	Lower	05 _H
Write-in word number	Upper	00 _H
	Lower	04 _H
Write-in byte number		08 _H
First write-in word data	Upper	07 _H
	Lower	D0 _H
Next write-in word data	Upper	03 _H
	Lower	E8 _H
Next write-in word data	Upper	03 _H
	Lower	84 _H
Last write-in word data	Upper	00 _H
	Lower	64 _H
CRC data	Lower	0B _H
	Upper	FF _H

Response message composition (byte)

Station No.		01 _H
Function code		10 _H
Write-in start No.	Upper	00 _H
	Lower	05 _H
Write-in word number	Upper	00 _H
	Lower	04 _H
CRC data	Lower	D1 _H
	Upper	CB _H



Since the transmission data can not include a decimal point, data of 2.000 is transmitted as "2000".

For transmission format of each data, refer to the Address map (Chapter 7).

7. ADDRESS MAP AND DATA FORMAT

7.1 Data format

7.1.1 Transmission data format

The MODBUS protocol used in this instrument is RTU (Remote Terminal Unit) mode. Transmitted data is "numeric value" and not ASCII code".

7.1.2 Handling of decimal point position and measurement unit

When transmitted, the calibration concentration setting, alarm's high and low limits and measurement concentration data have no decimal point nor measurement unit.

Calculate exact values of data upon point positioning as shown below.

- (a) Calibration concentration setting (register No. 40001 to 40004)
Alarm setting (register No. 40006 to 40009)

Decimal point position that corresponds to each range can be known by reading the decimal point position data (Register No. 30002).

The decimal point position data has a value of 0, 1, 2 or 3. You can obtain an exact value by the following calculation.

- Case 0: Calibration concentration setting data /1
- Case 1: Calibration concentration setting data /10
- Case 2: Calibration concentration setting data /100
- Case 3: Calibration concentration setting data /1000

For example, in the case;

Range 1 span calibration concentration set value (Register No. 40002 = 3000, and
Range1 decimal point position (Register No. 30002) = 3, the value will be 3.000 vol%.

For writing-in, proceed in the reverse. To obtain 3.000 vol%, write 3000 as calibration concentration setting.

The decimal point position and unit are unchangeable because fixed to each CH and each range.

(b) Measurement concentration (register No. 30001)

The decimal point position for each concentration are stored in registers following that of concentration, and can be known by reading them in.

The meaning of decimal point position data and measurement unit data values are the same as in (a) above.

For example, if:

Measurement concentration (register No. 30001) = 1270,

Decimal point position (register No. 30002) = 3,

the value is 12.70 vol%

7.1.3 Handling at measurement data over-range

Even if the measurement data is at over-range, with "— — —" displayed on the screen, the concentration that stands then is transmitted as read-out measurement concentration.

7.2 Address map

For details of functions and settable ranges of different parameters, refer to the instruction manual for the analyzer.

Word data [read-out/write-in]: Function code [03_H, 06_H, 10_H]

User settings

Relative address	Register No.	Data type	Memory contents	Read/Write data	Remarks Corresponding parameters
0000 _H	40001	INT	Range1 zero calibration concentration	0 to 9999	cal_val[0][0] cal_val[1][1]
0001 _H	40002	INT	Range1 span calibration concentration	Decimal point position varies by that of each range	
0002 _H	40003	INT	Range2 zero calibration concentration		
0003 _H	40004	INT	Range2 span calibration concentration		
0004 _H	40005	INT	Calibration status	0: Display range, 1: Range interlock	calstate
0005 _H	40006	INT	Range1 alarm 1-step set value	0 to 9999	limit[0][0] limit[1][1]
0006 _H	40007	INT	Range1 alarm 2-step set value	Decimal point position varies by that of each range	
0007 _H	40008	INT	Range2 alarm 1-step set value		
0008 _H	40009	INT	Range2 alarm 2-step set value		
0009 _H	40010	INT	Alarm mode	0: Upper limit 1-step, 1: Upper limit 2-step, 2: Lower limit 1-step, 3: Lower limit 2-step, 4: Upper lower limit, 5: Upper limit + Lower limit	limit_mode
000A _H	40011	INT	Alarm switch	0: Alarm OFF, 1: Alarm ON	limit_sw
000B _H	40012	INT	Alarm hysteresis	0 _H to 14 _H (0 to 20% FS)	hyster
000C _H	40013	INT	Automatic calibration start time (Day-of-week)	0 _H to 07 _H (Sunday to Saturday)	acal_week
000D _H	40014	INT	Automatic calibration start time (Hour)	0 _H to 23 _H (BCD code)	acal_hour
000E _H	40015	INT	Automatic calibration start time (Minute)	0 _H to 58 _H (BCD code)	acal_min
000F _H	40016	INT	Automatic calibration cycle	1 to 99 hours/1 to 40 days	cal_cycle
0010 _H	40017	INT	Unit of automatic calibration cycle	0: Hour, 1: Day	cal_cycle_mode
0011 _H	40018	INT	Automatic calibration switch	0: OFF, 1: ON	raautcals
0012 _H	40019	INT	Automatic calibration gas flowing time	60 to 599 seconds	flow
0013 _H	40020	INT	Key-lock switch	0: OFF, 1: ON	rafkeylk
0014 _H	40021	INT	Remote range switch	0: OFF, 1: ON	rafremtra
0015 _H	40022	INT	Response speed	1 to 60 seconds	response[0]
0016 _H	40023	INT	Response speed (Temperature)	30 seconds	response[1]
0017 _H	40024	INT	Response speed (Interference component)	1 to 60 seconds	response[2]
0018 _H	40025	INT	Hold switch	0: OFF, 1: ON	rafholdst
0019 _H	40026	INT	Range changeover setting	0: Range1, 1: Range2	range_sel

Word data [read-out/write-in]: Function code [03_H, 06_H, 10_H]

User settings

Relative address	Register No.	Data type	Memory contents	Read/Write data	Remarks Corresponding parameters
001A _H	40027	INT	Backlight switch	0: OFF, 1: ON	back_light_sw
001B _H	40028	INT	Backlight out time	5 to 99 minutes	back_light_time
001C _H	40029	INT	Contact output allocation (1)	0: Always off, 1: Zero valve, 2: Span valve, 3: Calibrating status, 4: Pump, 5: Upper limit alarm, 6: Upper limit 2-step alarm, 7: Lower limit alarm, 8: Lower limit 2-step alarm, 9: Upper lower limit alarm, 10: Analyzer error, 11: Range identification, 12: Always on	doutse11
001D _H	40030	INT	Contact output allocation (2)		doutse12
001E _H	40031	INT	Contact output allocation (3)		doutse13
001F _H	40032	INT	Contact output allocation (4)		doutse14
0020 _H	40033	INT	Contact output allocation (5)		doutse15
0021 _H	40034	INT	Range1 measurement screen decimal point position	0: No decimal point position, 1: one digit below decimal point, 2: 2 digits below decimal point, 3: 3 digits below decimal point	disp_digit_pos[0]
0022 _H	40035	INT	Range2 measurement screen decimal point position		disp_digit_pos[1]
0023 _H	40036	INT	Date/time display flag	0: Non-display, 1: Display	disp_watch_flg

Word data [read-out only] : Function code[04_H]

User data

Relative address	Register No.	Data type	Memory contents	Readout data	Remarks Corresponding parameters
0000 _H	30001	INT	Concentration value	Concentration value: -9999 to 9999 (Display value equivalent to no decimal point value) Decimal point position: 0, 1, 2, or 3. (0: Concentration value /1 1: Concentration value /10 2: Concentration value /100 3: Concentration value /1000)	
0001 _H	30002	INT	Decimal point position		
0002 _H	30003	INT	Reserved		
0003 _H	30004	INT	Concentration value		
0004 _H	30005	INT	Concentration value's decimal point position		
0005 _H	30006	INT	Reserved		
0006 _H	30007	INT	Interference component's concentration value		
0007 _H	30008	INT	Interference component's decimal point position		
0008 _H	30009	INT	Reserved		
0009 _H	30010	INT	Current range	0:Range1, 1:Range2	r ange_id_cur
000A _H	30011	INT	1-step alarm	0:No alarm, 1:Alarming status	
000B _H	30012	INT	2-step alarm	0:No alarm, 1:Alarming status	
000C _H	30013	INT	Automatic calibrating status	0:None, 1: Calibrating status	
000D _H	30014	INT	Zero calibrating status	0:None, 1: Calibrating status	
000E _H	30015	INT	Span calibrating status	0:None, 1: Calibrating status	
000F _H	30016	INT	Analyzer error	0:None, 1: Error	
0010 _H	30017	INT	Latest error No	-1: Empty, 4 to 9 1 to 7 (Sunday to Saturday) 0 to 23 (Hour) 0 to 59 (Minute)	Transmits sequentially from latest error.
0011 _H	30018	INT	Latest error WEEK		
0012 _H	30019	INT	Latest error HOUR		
0013 _H	30020	INT	Latest error MIN		
0014 _H	30021	INT	Reserved		
0015 _H	30022	INT	Previous error No	-1: Empty, 4 to 9 1 to 7 (Sunday to Saturday) 0 to 23 (Hour) 0 to 59 (Minute)	
0016 _H	30023	INT	Previous error WEEK		
0017 _H	30024	INT	Previous error HOUR		
0018 _H	30025	INT	Previous MIN		
0019 _H	30026	INT	Reserved		
to	to	to	to	to	

Word data [read-out only] : Function code[04_H]

User data

Relative address	Register No.	Data type	Memory contents	Readout data	Remarks Corresponding parameters
0051 _H	30082	INT	Oldest error No	-1: Empty, 4 to 9 1 to 7 (Sunday to Saturday) 0 to 23 (Hour) 0 to 59 (Minute)	
0052 _H	30083	INT	Oldest error WEEK		
0053 _H	30084	INT	Oldest error HOUR		
0054 _H	30085	INT	Oldest error MIN		
0055 _H	30086	INT	Reserved		
0056 _H	30087	INT	Error No.4	0:None, 1:Error occurs	
0057 _H	30088	INT	Error No.5		
0058 _H	30089	INT	Error No.6		
0059 _H	30090	INT	Error No.7		
005A _H	30091	INT	Error No.8		
005B _H	30092	INT	Error No.9		
005C _H	30093	INT	Automatic zero calibrating status	0:Off, 1:On	
005D _H	30094	INT	Automatic span calibrating status		
005E _H	30095	INT	Holding status		
005F _H	30096	INT	Screen information (1)		
0060 _H	30097	INT	Reserved		
0061 _H	30098	INT	Reserved		
0062 _H	30099	INT	Key operation management information		manual_key
0063 _H	30100	INT	Latest calibration history	-1:Empty, 0:Zero calibration, 1:Span calibration	cal_log_area[]
0064 _H	30101	INT	Calibration coefficient	Zero /span calibration coefficient	
0065 _H	30102	INT	Analog input value	Analog input value at calibration time	
0066 _H	30103	INT	Year, month	Year:0 to 99, Month: 1 to 12	
0067 _H	30104	INT	Date, hour	Date: 1 to 31, Hour: 0 to 23	
0068 _H	30105	INT	Minute, second	Minute: 0 to 59, Second: 0 to 59	

Word data: Function code [06H]

For adjustment (Only word by word writing allowed)

Relative address	Register No.	Data type	Memory contents	Read/Write data	Remarks Corresponding parameters
07D0 _H	42001	BYTE	Key operation command	80H:MODE, 40H: Right or left, 20H:Up, 10H:Down, 0.8H:ESC, 04H:ENT02H:ZERO, 01H:SPAN	entern_key
07D1 _H	42002	INT	Screen switching	1:Returns to Measurement screen	backto_meas_flg
07D2 _H	42003	INT	Main unit reset	1:Resets Main unit	reset_flg

7.3 Supplement to address map

* (1) Register No. 30017 to 30085 (Error log)

From Error log, up to 14 errors occurred in the past can be read sequentially from newer one.

The contents are,

Error No.: Occurred error number. The stored value is the value decremented by 1 from the error number

Error WEEK: Day-of week when the error occurred

Error HOUR: Hour when the error occurred

Error MIN: Minute when the error occurred

* (2) Register No. 30096 (Screen information (1))

The screen information is the value to know the current screen status of the Analyzer.

- Screen information (1): Contents of the value (status of each setting screen),

0: Measurement mode screen (incl. Manual calibration screen)

1: Menu mode screen

2: Range changeover screen

3: Calibration setting screen

4: Alarm setting screen

5: Automatic calibration setting screen

6: Interference correction

7: Parameter mode screen

8: Maintenance mode screen

9: Factory mode screen

8. SAMPLE PROGRAM

This chapter concerns data read-out/write-in sample program which operates on N88-Japanese BASIC (*2) for PC-9801 (*1) or compatible PCs.

Note that the program shown here is for reference for you to create a program and not for guaranteeing all actions.

Before executing the program, make sure of the communication conditions in the following procedure.

- Communication speed (baud rate):

Match the conditions with this instrument using SWITCH command and SPEED command of MS-DOS (*3).

For SWITCH command and SPEED command, refer to the reference manual of MS-DOS.

- Data length, stop bits and parity:

Set in this program. Match the conditions with this instrument.

*1 PC-9801 series are products of NEC Corporation.

*2 N88-Japanese BASIC is a registered trade mark of NEC Corporation.

*3 MS-DOS is a registered trade mark of Microsoft Corporation.

(a) Example of data read-out

Operation: Read-out CH1 measurement concentration value.

(Continuous word read-out from read-out only area)

Used function code : 04H

Read-out start register No. : 30001

Read-out word number : 3

```
1000 '-----
1010 '  READ CONTINUOUS WORDS    SAMPLE PROGRAM
1020 '-----
1030 '
1040 ' Transmission speed = 9600 bps (selected with SPEED command and SWITCH command of MS-DOS)
1050 '
1060 CLS
1070 DIM CC(255)
1080 '
1100 '----- Send data setting -----
1110 CC(1)=&H01      'Station No.    = 1
1120 CC(2)=&H04      'Function code = 04H
1130 CC(3)=&H00      'Upper byte of relative address(0000H) of resister No.30001
1140 CC(4)=&H00      'Lower byte of relative address(0000H) of resister No.30001
1150 CC(5)=&H00      'Upper byte of read-out word data(0003H)
1160 CC(6)=&H03      'Lower byte of read-out word data(0003H)
1170 COUNT=6
1200 '
1210 '----- CRC code calculation of send data -----
1220 GOSUB *CRC.CALC
1230 CC(7)=CRC.L      'Lower byte of CRC calculation result → Upper byte in message
1240 CC(8)=CRC.H      'Upper byte of CRC calculation result → Lower byte in message
1250 COUNT=COUNT+2
1300 '
1310 '----- Send data -----
1320 PRINT " Sending data > ";
1330 OPEN "COM1:N81NN" AS #1      ' No parity ... "N81NN"
1340
1350
1360 FOR I=1 TO COUNT
1370  PRINT #1,CHR$(CC(I));          'Writing in transmission port
1380  PRINT RIGHT$("0"+HEX$(CC(I)),2);" "; 'Displaying on screen
1390 NEXT I
1400 '
1410 FOR I=0 TO 12000 :NEXT I      ' Interval time
1500 '

```

```

1510 '----- Data receive -----
1520 PRINT
1530 LENGTH=LOC(1)           'Number of data in receiving buffer
1540 IF LENGTH=0 THEN PRINT "No answer" :END
1550 PRINT " Receiving data < ";
1560 FOR I=1 TO LENGTH
1570   X$=INPUT$(1,#1)       'Taking data from receiving buffer
1580   CC(I)=ASC(X$)         'Digitizing and storing
1590   PRINT RIGHT$("0"+HEX$(CC(I)),2);" "; 'Displaying on screen
1600 NEXT I
1610 CLOSE #1
1620 COUNT=LENGTH-2
1630 GOSUB *CRC.CALC
1700 '
1710 '----- Transmission error check -----
1720 PRINT
1730 CRC.L$=RIGHT$("0"+HEX$(CRC.L),2)
1740 CRC.H$=RIGHT$("0"+HEX$(CRC.H),2)
1750 PRINT "CRC calculation = ";CRC.L$;" ";CRC.H$
1760 IF CC(LENGTH-1)<>CRC.L THEN GOTO *ER.MESSAGE
1770 IF CC(LENGTH)<>CRC.H THEN GOTO *ER.MESSAGE
1780 GOTO *PRT.RESULT
1790 *ER.MESSAGE
1800 PRINT "Communication error"
1810 END
1900 '
1910 '----- Display of result -----
1920 *PRT.RESULT
1930
1940 PRINT
1950 VALUE=HEX$(CC(4))+RIGHT$("0"+HEX$(CC(5)),2)  '2byte → 1word
1960 DE$=HEX$(CC(6))+RIGHT$("0"+HEX$(CC(7)),2)  '2byte → 1word
1970     IF VAL("&H"+DE$)=0 THEN CONC=VAL("&H"+VALUE$)/1
1980     IF VAL("&H"+DE$)=0 THEN CONC=VAL("&H"+VALUE$)/10
1990     IF VAL("&H"+DE$)=0 THEN CONC=VAL("&H"+VALUE$)/100
2000     IF VAL("&H"+DE$)=0 THEN CONC=VAL("&H"+VALUE$)/1000
2010 UNIT$="vol%"
2020
2030
2020 Print "CH1 measurement concentration =";CONC;UNIT
2030 END
3000 '

```

```
3010 '----- CRC calculation -----
3020 *CRC.CALC          ' For contents, refer to CRC calculation flow chart
3030 CR=&HFFFF
3040 FOR I=1 TO COUNT
3050 CR=CR XOR CC(I)
3060 FOR J=1 TO 8
3070 CT=CR AND &H1
3080 IF CR<0 THEN CH=1 ELSE CH=0:GOTO *CRC.CALC.10
3090 CR=CR AND &H7FFF
3100 *CRC.CALC.10
3110 CR=INT(CR/2)
3120 IF CH=1 THEN CR=CR OR &H4000
3130 IF CT=1 THEN CR=CR XOR &HA001
3140 NEXT J
3150 NEXT I
3160 CRC.L=CR AND &HFF          ' Lower byte of CRC calculation
3170 CRC.H=((CR AND &HFF00)/256 AND &HFF) ' Upper byte of CRC calculation
3180 RETURN
```

(b) Data write-in example

Operation : Change CHI measurement range via communication

(Single word write-in)

Used function code : 06H

Write-in register No. : 40026

Write-in data : 1 (changeover from range 1 to range 2)

```
1000 '-----
1010 '  WRITE 1 WORD      SAMPLE PROGRAM
1020 '-----
1030 '
1040 ' Transmission speed = 9600 bps (selected with SPEED command and SWITCH command of MS-DOS)
1050 '
1060 CLS
1070 DIM CC(255)
1080 '
1100 '----- Send data setting -----
1110 CC(1)=&H01      ' Station No.      = 1
1120 CC(2)=&H06      ' Function code = 06H
1130 CC(3)=&H00      ' Upper byte of relative address(0019H) of resister No.40106
1140 CC(4)=&H19      ' Lower byte of relative address(0019H) of resister No.40106
1150 CC(5)=&H00      ' Upper byte of Write-in word data(0001H)
1160 CC(6)=&H01      ' Lower byte of Write-in word data(0001H)
1170 COUNT=6
1200 '
1210 '----- CRC code calculation of send data -----
1220 GOSUB *CRC.CALC
1230 CC(7)=CRC.L      ' Lower byte of CRC calculation result → Upper byte in message
1240 CC(8)=CRC.H      ' Upper byte of CRC calculation result → Lower byte in message
1250 COUNT=COUNT+2
1300 '
1310 '----- Send data -----
1320 PRINT "Sending data > ";
1330 OPEN "COM1:N81NN" AS #1      ' No parity ... "N81NN "
1340
1350
1360 FOR I=1 TO COUNT
1370   PRINT #1,CHR$(CC(I));      ' Writing transmission port
1380   PRINT RIGHT$("0"+HEX$(CC(I)),2);" "; ' Displaying on screen
1390 NEXT I
1400 '
1410 FOR I=0 TO 12000 :NEXT I      ' Interval time
1500 '

```

```

1510 '----- Data receive -----
1520 PRINT
1530 LENGTH=LOC(1) 'Number of data in receiving buffer
1540 IF LENGTH=0 THEN PRINT "No answer" :END
1550 PRINT "Receiving data < ";
1560 FOR I=1 TO LENGTH
1570 X$=INPUT$(1,#1) 'Taking data from receiving buffer
1580 CC(I)=ASC(X$) 'Digitizing and storing
1590 PRINT RIGHT$("0"+HEX$(CC(I)),2);" "; 'Displaying on screen
1600 NEXT I
1610 CLOSE #1
1620 COUNT=LENGTH-2
1630 GOSUB *CRC.CALC
1700 '
1710 '----- Transmission error check -----
1720 PRINT
1730 CRC.L$=RIGHT$("0"+HEX$(CRC.L),2)
1740 CRC.H$=RIGHT$("0"+HEX$(CRC.H),2)
1750 PRINT "CRC calculation = ";CRC.L$;" ";CRC.H$
1760 IF CC(LENGTH-1)<>CRC.L THEN GOTO *ER.MESSAGE
1770 IF CC(LENGTH)<>CRC.H THEN GOTO *ER.MESSAGE
1780 GOTO *PRT.RESULT
1790 *ER.MESSAGE
1800 PRINT "Communication error"
1810 END
1900 '
1910 '----- Display of result -----
1920 *PRT.RESULT
1930 PRINT
1940 PRINT " Range change ended "
1950 END
3000 '
3010 '----- CRC calculation -----
3020 *CRC.CALC 'For contents, refer to CRC calculation flow
3030 CR=&HFFFF
3040 FOR I=1 TO COUNT
3050 CR=CR XOR CC(I)
3060 FOR J=1 TO 8
3070 CT=CR AND &H1
3080 IF CR<0 THEN CH=1 ELSE CH=0:GOTO *CRC.CALC.10
3090 CR=CR AND &H7FFF
3100 *CRC.CALC.10
3110 CR=INT(CR/2)
3120 IF CH=1 THEN CR=CR OR &H4000
3130 IF CT=1 THEN CR=CR XOR &HA001
3140 NEXT J
3150 NEXT I
3160 CRC.L=CR AND &HFF 'Lower byte of CRC calculation
3170 CRC.H=((CR AND &HFF00)/256 AND &HFF) 'Upper byte of CRC calculation
3180 RETURN

```

9. TROUBLESHOOTING

If the communication is unavailable, check the following items.

- Whether all devices related to communication are turned on.
- Whether connections are correct.
- Whether the number of connected instruments and connection distance are as specified
- Whether communication conditions coincide between the master station (host computer) and slave stations (instrument)
 - Transmission speed : 9600bps
 - Data length : 8 bits
 - Stop bit : 1 bit
 - Parity : None

- Whether send/receive signal timing conforms to Section 5.6 in this manual.
- Whether the station No. designated as send destination by the master station coincides with the station No. of the connected instrument.
- Whether more than one instrument connected on the same transmission line shares the same station No.
- Whether the station No. of instruments is set at other than 0.
If it's 0, the communication function does not work.

Fuji Electric Systems Co., Ltd.

Head Office

Gate City Ohsaki, East Tower, 11-2, Osaki 1-chome,
Shinagawa-ku, Tokyo 141-0032, Japan
<http://www.fesys.co.jp/eng>

Instrumentation Div.

International Sales Dept.

No.1, Fuji-machi, Hino-city, Tokyo 191-8502, Japan
Phone: 81-42-585-6201, 6202 Fax: 81-42-585-6187
<http://www.fic-net.jp/eng>
