



Instruction Manual

**INFRARED GAS ANALYZER  
(INSTALLATION MANUAL)**

TYPE: ZSU-3

# PREFACE

---

We are grateful for your purchase of Fuji Infrared Gas Analyzer, TYPE: ZSU.

- Read this installation manual carefully to understand the installation procedure fully prior to commencing the work. Improper installation may result in an accident or injury.
- The specifications of this analyzer are subject to change without prior notice for further product improvement.
- Modification of this analyzer is strictly prohibited unless a written approval is obtained from the manufacturer. Fuji will not bear any responsibility for a trouble caused by such a modification.
- Those who actually install the gas analyzer should read and keep this installation manual near at hand.
- After reading the manual, be sure to store it at a place easier to access.
- Make sure that this installation manual is handed over to the installation service that actually performs the work.

Manufacturer: Fuji Electric Instrumentation Co., Ltd.  
Type: Described in nameplate on main frame  
Date of manufacture: Described in nameplate on main frame  
Product nationality: Japan

## Request

- It is prohibited to transfer part or all of this manual without Fuji's permission in written format.
- Description in this manual is subject to change without prior notice for further improvement.

© Fuji Electric Systems Co., Ltd. 2005



Issued in September, 2005



# CAUTION ON SAFETY

---

First of all, read this “Caution on safety” carefully, and then install the analyzer in the correct way.

- The cautionary descriptions listed here contain important information about safety, so they should always be observed. Those safety precautions are ranked in 3 levels, “DANGER”, “CAUTION” and “PROHIBITION”.

 <b>DANGER</b>	<p>Wrong handling may cause a dangerous situation, in which there is a risk of death or heavy injury.</p>
 <b>CAUTION</b>	<p>Wrong handling may invite a dangerous situation, in which there is a possibility of medium-level trouble or slight injury or only physical damage is predictable.</p>
 <b>PROHIBITION</b>	<p>Items which must not be done are noted.</p>

<b>Caution on installation, re-installation and storage of gas analyzer</b>	
 <b>DANGER</b>	<ul style="list-style-type: none"> <li>• This unit is not explosion-proof type. Do not use it in a place with explosive gases to prevent explosion, fire or other serious accidents.</li> </ul>
 <b>CAUTION</b>	<ul style="list-style-type: none"> <li>• Entrust the installation, movement or re-installation to a specialist or the supplier. A poor installation may cause accidental tipover, shock hazard, fire, injury, etc.</li> <li>• The gas analyzer is heavy. It should be installed with utmost care. Otherwise, it may tip over or drop, for example, causing accident or injury.</li> <li>• For lifting the gas analyzer, be sure to wear protective gloves. Bare hands may invite an injury.</li> <li>• This unit should be installed in a place which conforms to the conditions noted in the instruction manual. Otherwise, it may cause electric shocks, fire or malfunction of the unit.</li> <li>• During installation work, care should be taken to keep the unit free from entry of cable chips or other foreign objects. Otherwise, it may cause fire, trouble or malfunction of the unit.</li> <li>• For discharging the exhaust gas, carry out piping up to a position which is not easily accessible by persons so as not to adversely affect the human body.</li> </ul>

---

---

**Caution on wiring**



**CAUTION**

- Entrust the wiring to a specialist or the supplier. Poor wiring may cause shock hazard or injury.
- Enforce construction of class-D grounding wire by all means. If the specified grounding construction is neglected, a shock hazard or fault may be caused.

**Caution to wiring electrician**

**For avoiding shock hazard, fire and injury, be sure to observe the following.**

- Before wiring, be sure to turn off the main power supplies. This is required for preventing a shock hazard.
- As a ground wire, use 600V-IV wire of 2 mm<sup>2</sup> or thicker having a sufficient dielectric strength. Use of a wrong ground wire may cause shock hazard or malfunction.
- Input/output wires should have proper diameters meeting the rated current of the gas analyzer. If a wire which cannot endure the rating is used, a fire may occur.
- For connection to input and output terminal blocks, be sure to use solderless terminals.
- For branching the output wires, use a terminal block.
- Be sure to fasten the input/output wires on the floor, wall, etc. and put guards on the wires.
- Do not install the instrument near high frequency heating furnace, electric welding machine or others which considerably disturb the power waveforms. Do not share their power supplies either.

**Others**



**CAUTION**

- If the cause of any fault cannot be determined despite reference to the instruction manual, be sure to contact your dealer or Fuji's technician in charge of adjustment. If the instrument is disassembled carelessly, you may have a shock hazard or injury.

# CONTENTS

---

PREFACE .....	i
CAUTION ON SAFETY .....	ii
CONTENTS .....	iv
1. INSTALLATION .....	1
1.1 Selecting location of analyzer .....	1
1.2 Selecting location of gas extractor .....	1
1.3 Installation of analyzer .....	2
1.3.1 External dimensions .....	2
1.3.2 Anchor bolt mounting dimensions .....	2
1.3.3 Maintenance space .....	2
1.3.4 Vibration proof measures .....	2
1.4 Installation of gas extractor .....	3
1.4.1 Dimensions of gas extractor .....	3
1.4.2 Mounting conditions for gas extractor .....	4
1.4.3 Assembly of gas extractor .....	5
2. PIPING .....	6
2.1 Piping diagram .....	6
2.2 Placing of heating tube (tube trace) .....	7
2.3 Piping of gas extractor .....	10
2.4 Piping of analyzer interior .....	11
3. WIRING .....	12
3.1 External connection diagram .....	12
3.2 Wiring .....	13
3.2.1 Terminal blocks (retain particular manufacturing specifications, if any) .....	14

# 1. INSTALLATION

---

## DANGER

This unit is not explosion-proof type. Do not use it in a place with explosive gases to prevent explosion, fire or other serious accidents.

## CAUTION

- Entrust the installation, movement or re-installation to a specialist or the supplier. A poor installation may cause accidental tipover, shock hazard, fire, injury, etc.
- The gas analyzer is heavy. It should be installed with utmost care. Otherwise, it may tip over or drop, for example, causing accident or injury.
- For lifting the gas analyzer, be sure to wear protective gloves. Bare hands may invite an injury.
- This unit should be installed in a place which conforms to the conditions noted in the instruction manual. Otherwise, it may cause electric shocks, fire or malfunction of the unit.
- During installation work, care should be taken to keep the unit free from entry of cable chips or other foreign objects. Otherwise, it may cause fire, trouble or malfunction of the unit.

## 1.1 Selecting location of analyzer

To install the analyzer for optimum performance, select a location that meets the following conditions;

- (1) A place close to a gas sampling point (30 meter, max).
- (2) A place which is not exposed to direct sunlight or radiation heat from high temperature object.  
A place free from rain or water drops for indoor use.
- (3) A place which is free from dust or corrosive gas.
- (4) A vibration-free place.
- (5) A place where change in ambient temperature is minimum.
- (6) A place where a sufficient maintenance space can be secured (see “1.3.3 Maintenance space”).

## 1.2 Selecting location of gas extractor

For sampling measuring gases (for installing the gas extractor), select a location that meets the following conditions (see JIS K0095, K0103, Z8808).

- (1) Standard measuring gas conditions  
Temperature : 60° to 800°C  
Dust : 100mg/Nm<sup>3</sup> or less  
Pressure : -5 to +5kPa  
Components : SO<sub>2</sub>: 500 ppm or less, NO<sub>x</sub>: 1000 ppm or less, CO<sub>2</sub>: 15% or less,  
CO: 2000 ppm or less, O<sub>2</sub>: 21% or less, HCl: 1000ppm or less,  
the residual components: N<sub>2</sub>, H<sub>2</sub>O
- (2) A place where gas is ceaselessly supplied, and having a stack that is always filled with gases.
- (3) A place accessible for maintenance and check.
- (4) A place where pressure or temperature fluctuation is minimum.
- (5) A place where the analyzer can be mounted upon inserting it sidewise from the side wall of the stack or vertically from the ceiling.

## 1.3 Installation of analyzer

### 1.3.1 External dimensions

The external dimensions of analyzer locker (standard type) are as follows:

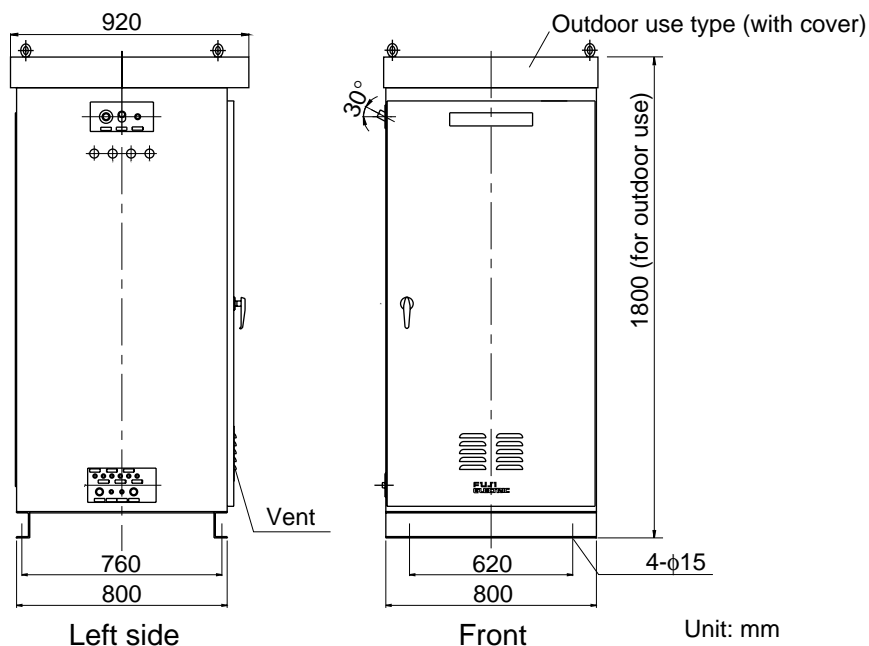

Fig. 1-1

### 1.3.2 Anchor bolt mounting dimensions

The mounting dimensions of anchor bolts that fix the analyzer locker are as follows:

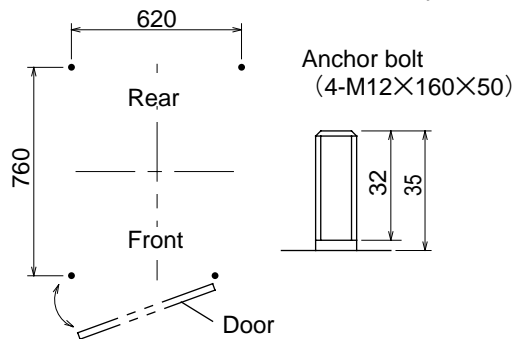

Fig. 1-2

Unit: mm

### 1.3.3 Maintenance space

A space with the following dimensions is provided for easy maintenance of the analyzer.

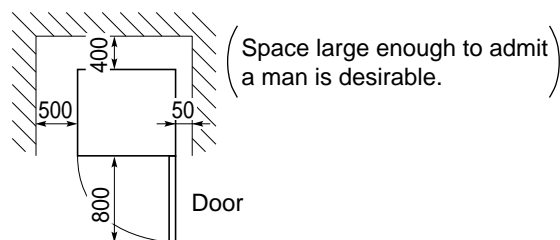

Fig. 1-3

Unit: mm

### 1.3.4 Vibration proof measures

To install it at a location which is subject to frequent vibration, place vibration proof rubber below the locker.

Tolerable vibration: 0.2 m/s<sup>2</sup> or less

## 1.4 Installation of gas extractor

### 1.4.1 Dimensions of gas extractor

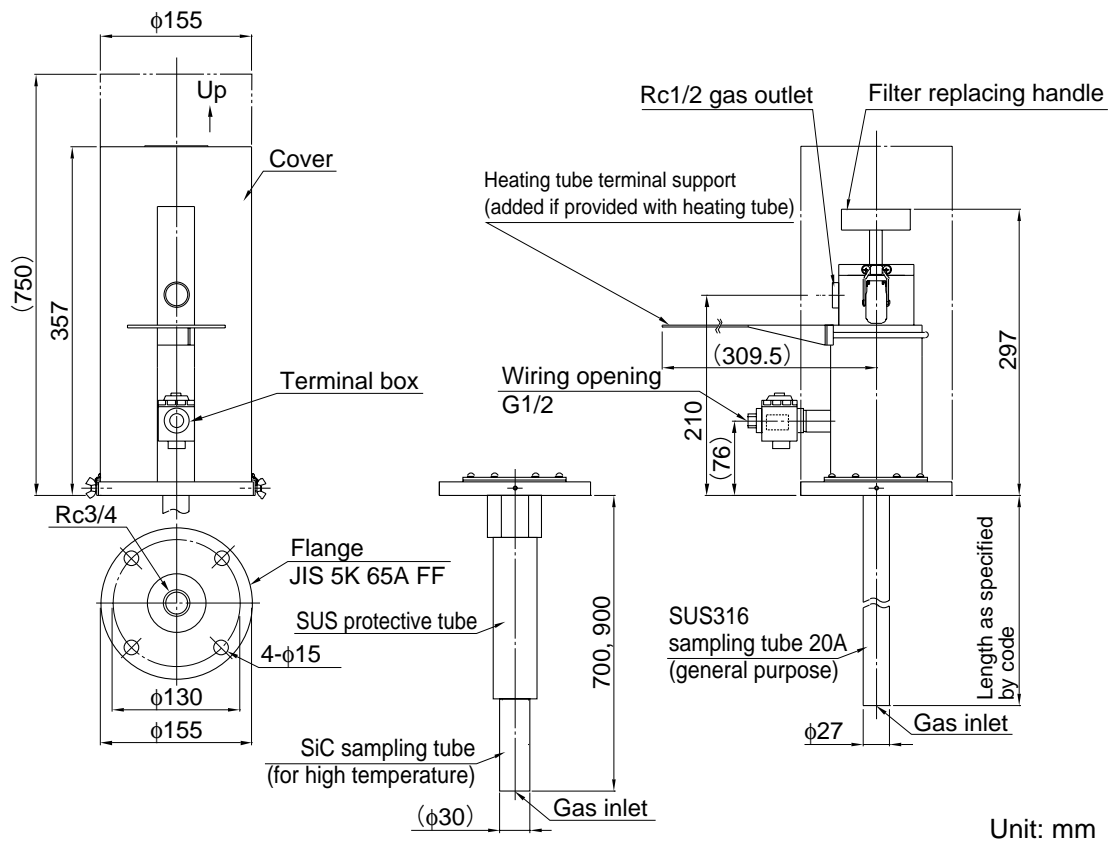

Fig. 1-4

### 1.4.2 Mounting conditions for gas extractor

To install the extractor, observe the following conditions:

- (1) Sampling gas temperature is within the specified range (general use: 800°C in max, high temperature: 1300°C in max.).
- (2) Perform processing or installation of mating flanges or protective tubes in advance to conform with the insertion angle limitations of each extractor.
  - Standard gas extractor flange: JIS 5K65AFF
  - Power requirements: 100 V AC, 50/60 Hz (100VA)
  - Limits of insertion angle (See Fig. 1-5)
  - General use: 90° to 0°
  - High temperature: 90° straight downward (to prevent damage to SiC tube)

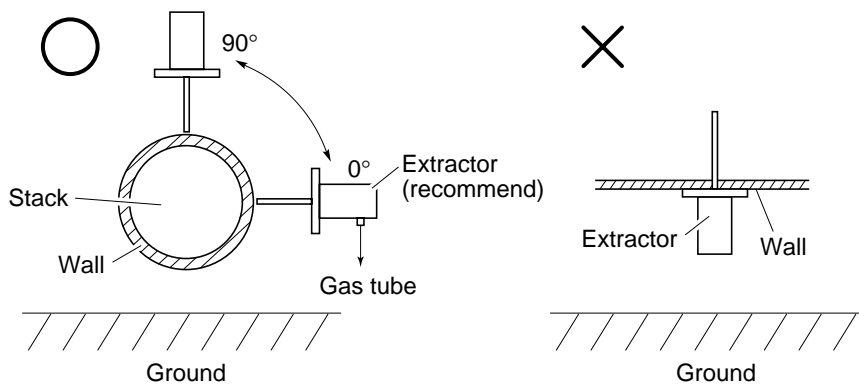

Fig. 1-5.

**Note) Be sure to mount the gas extractor so that its outlet faces downward to prevent the drain in sample gas from residing.**

- (3) Install the extractor so that the tip of sampling tube is located at the center of stack (separated more than 300 mm from the wall). A provision should be made to prevent aspiration of leak air as shown in Fig. 1-6. For high temperature device, install so that SUS protective tubes are not placed in the high temperature furnace. (see Fig. 1-4.)
- (4) Position the supplied packing under the flange beforehand.

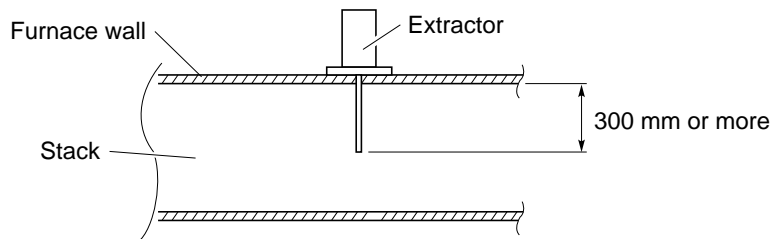

Fig. 1-6 Position of sampling tube

---

### 1.4.3 Assembly of gas extractor

#### (1) Mounting of gas sampling tube

Mount the supplied gas sampling tube on the gas extractor. (For dimensions, see “1.4.1 Dimensions of gas extractor”. For others, see separately submitted “Manufacturing specifications”.)

Wind Teflon seal tape on threads of the gas sampling tube, and screw it in the extractor flange.

#### (2) Mounting of heating tube terminal support

The heating tube can be mounted on the support plate.

##### 1) How to mount the heating tube support

Hold the extractor by supplied U bolt and reinforced plate, and mount it with plain washers, spring washers and nuts.

##### 2) How to mount the heating tube

Position the heating tube, and fasten it by supplied U bolts.

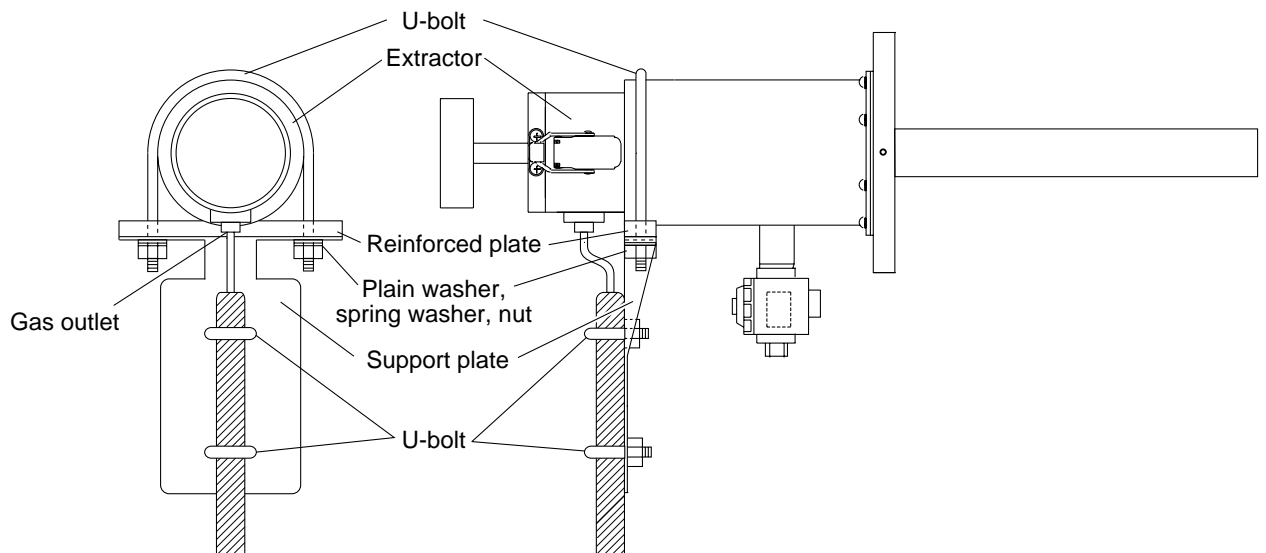

Fig. 1-7. Mounting of heating tube terminal support

**Note) Be sure to mount the gas extractor so that its outlet faces downward to prevent the drain in sample gas from residing.**

## 2. PIPING

### ⚠ CAUTION

- For discharging the exhaust gas, carry out piping up to a position which is not easily accessible by persons so as not to adversely affect the human body.

### 2.1 Piping diagram

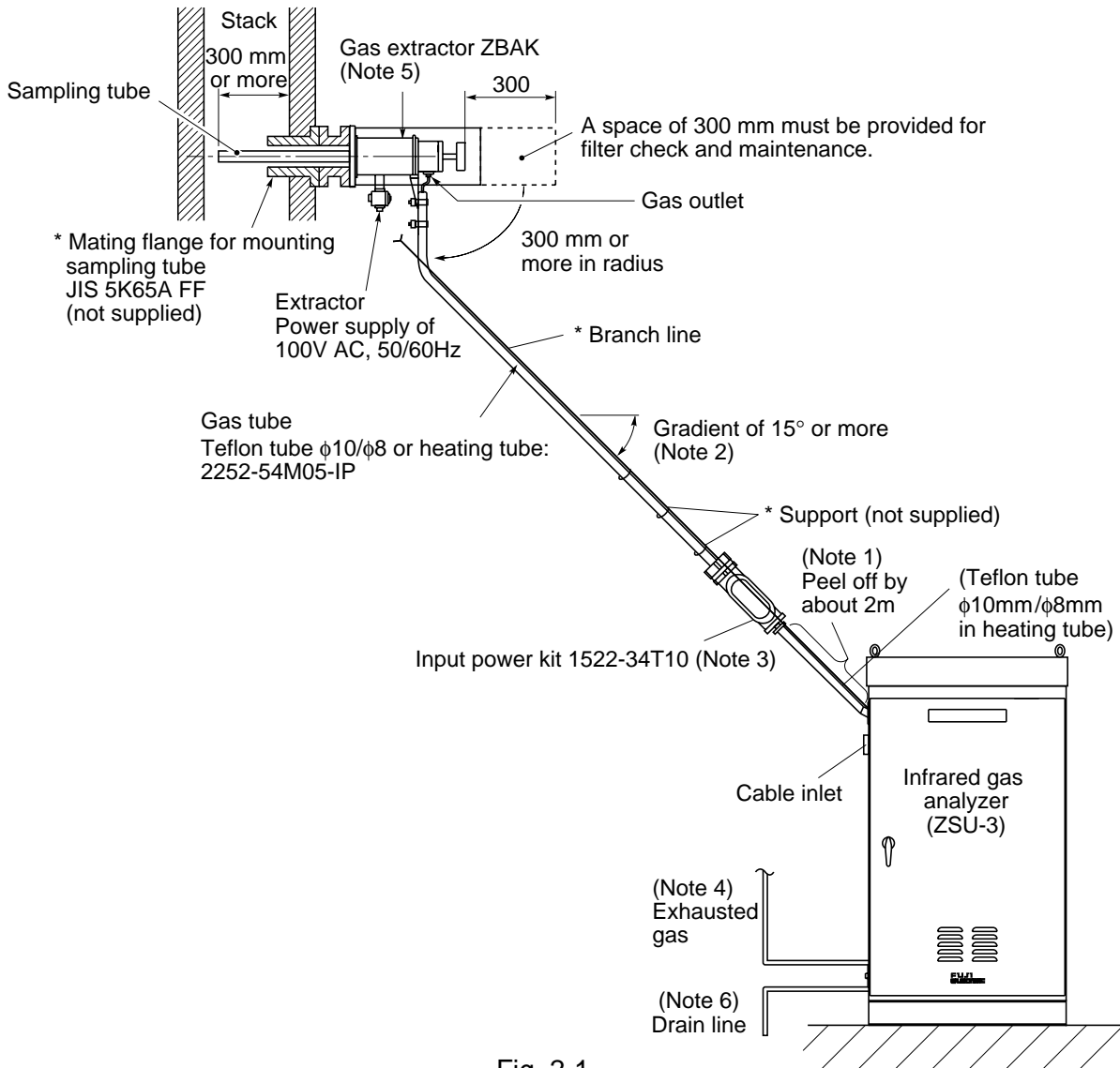
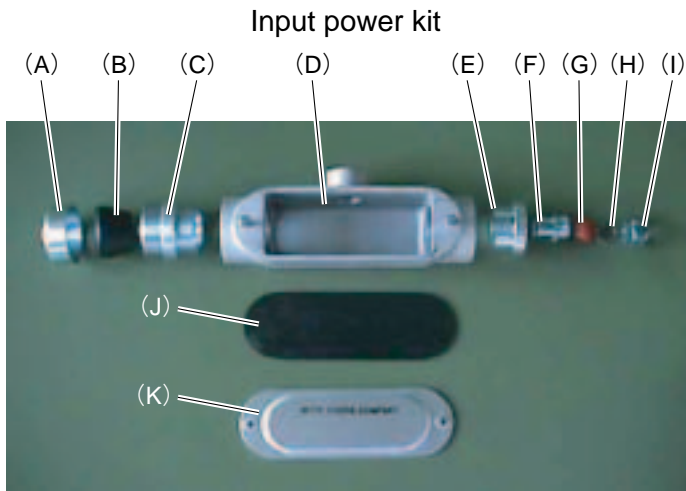

Fig. 2-1

- Note 1) Peel the heat tube by about 2 meters to air-cool measuring gas (See “12. The termination of heat tube”).
- Note 2) Tilt the gas tube at an angle of 15° or more so that drain won’t collect at the time of power interruption.
- Note 3) Input power kit is used together with the heat tube (See “12. The termination of heat tube”).
- Note 4) Install the piping outlet at a suitable place for exhausted gas not to affect the human body.
- Note 5) Keep the insertion angle within the limit (90° to 0° for the general use, and 90° downward for high temperature).
- Note 6) If there is a fear of freezing in winter, provide a thermal insulation means on the drain line from the equipment.

## 2.2 Placing of heating tube (tube trace)

### (1) Packing contents



### Supplied articles



- (a) Compression sleeve : 3 pcs (1 spare included)
- (b) Heat resisting tape : 1 pc
- (c) End sealant : 1 pc
- (d) Fiber glass tape : 1 pc
- (e) U bolts (M10 × 50A) : 2 pcs with nut and washer (4 pcs for each)

### (2) How to treat the end

- 1) Remove PVC cover, humidity preventive tape, thermal insulating material and soaking tape.

Removed length:  $(200 + L)$  mm

$L$  = distance from input power kit to process tube connecting section

Locate the heater grid position, and peel the altogether so as to be within 50 mm from the root (minimize the non-heating section).

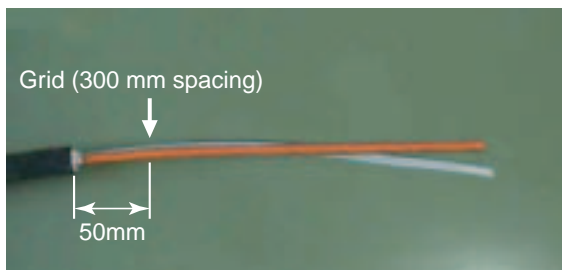

**Note) Paying attention not to damage the process tube nor heater wires, cut the altogether to a certain degree, and pull it out forcibly.**

- 2) Cut the heater wire at about 120 mm from the root.

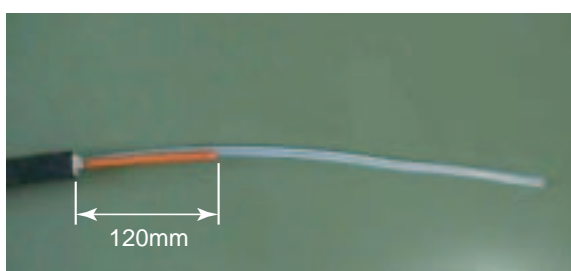

- 3) Strip the heater wires by about 50 mm from their free ends, and connect them with heat resisting wires or other power supply wires along with the compression sleeves (supplied article (a)), and insulate the compression sleeve areas and heater nichrome wire ends with heat resisting tape (supplied article (b)).



- 4) Pass the gland nut (A) and sealing bushing (B) on the bundle.



- 5) Apply end sealant (supplied article (c)) for preventing moisture, corrosive gases, etc. from coming in through the bundle end. It takes 24 hours for the end sealant to completely set. After coating, do not move the altogether excessively.

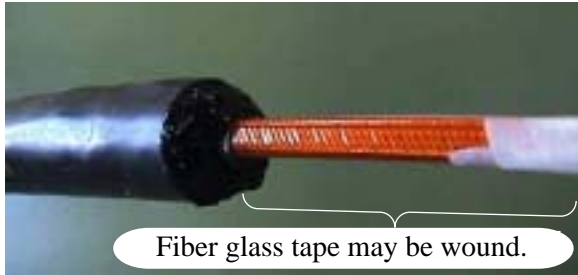

**Note) Winding the exposed heater section by the fiber glass tape (supplied article (d)) improves the thermal insulation there.**

- 6) Wind seal tape on connector body (C) and reducer (E), and screw them in connection box (D).



- 7) Pass the process tube and power supply wires first, and then insert the bundle into the connection box. Fold back the power supply wires in the box taking care so that their connections with the heater conductors will not bend.



- 8) Pass the connector body (F), sealing bushing (G), washer (H) and nut (I) for the process tube protected by sealing tape, and securely tighten the bundle side gland nut.



- 9) Install gasket (J) and cover (K)



- 10) Finally, fasten the cover by screws securely.



- 11) Mount the heating tube to a designated place using the supplied U bolt (e). (Refer to Fig. 2-1.)

### (3) Precautions in piping

- 1) Do not give excessive stresses (over 10 kgf) to a section between supports nor junctions.

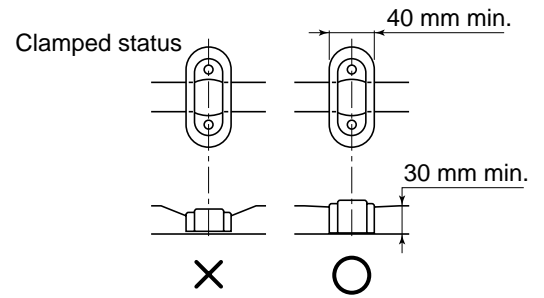

- 2) For supporting the tube, use commercially available electrical conduit clamps that match the bundle outer diameter, paying attention to their spacing so that the excessive stresses will not be applied to the bundle.

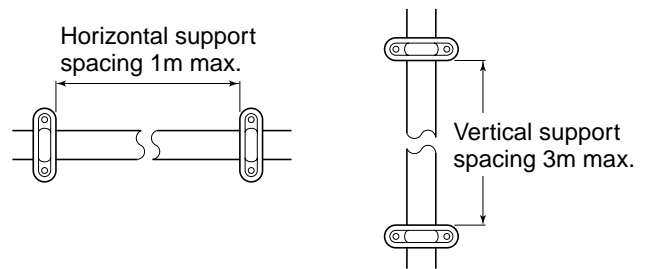

- 3) Do not bend the piping below the minimum allowable curvature radius. Do not clamp the piping on any curvature.

**Minimum allowable curvature radius : 300 mm**

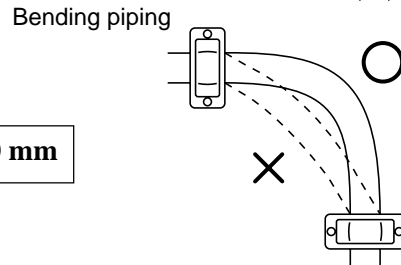

- 4) Never collect bundles together, nor coil them together, nor put a bundle in a pipe to avoid excessive heating or other troubles.

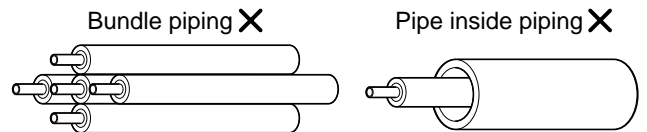

- 5) If bundles are placed on ground, never step on nor give stresses to them.

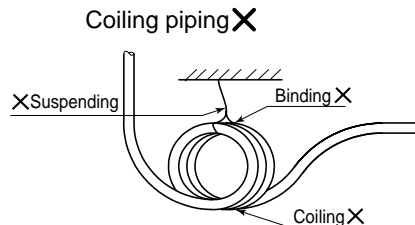

- 6) Place 2 or more bundles in parallel at least 25 mm away from each other.

Spacing for parallel piping

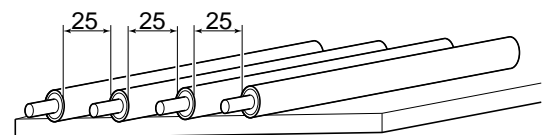

- 7) Refrain from piping where the temperature exceeds 40°C (boiler, heat exchanger, reaction tower or the like).

- 8) Avoid piping at -10°C or lower. Otherwise, clamping or bending may give stresses to bundles, thereby damaging them.

- 9) Limit the difference in atmospheric temperature to below 40°C so as not to adversely affect the internal temperature.

---

## 2.3 Piping of gas extractor

### (1) Sampling tube

- 1) The tube material must be corrosion resistant and one that won't affect the composition of sampling gases. Teflon tube is recommended.
- 2) Prepare tube couplings (Rc1/2) separately for SUS tube or SGP tube.
- 3) The pipe from the extractor should be tilted to an angle of 15° or more to allow condensed water to flow. Especially care should be paid to tilting at the outlet of extractor. See Fig. 4-6.

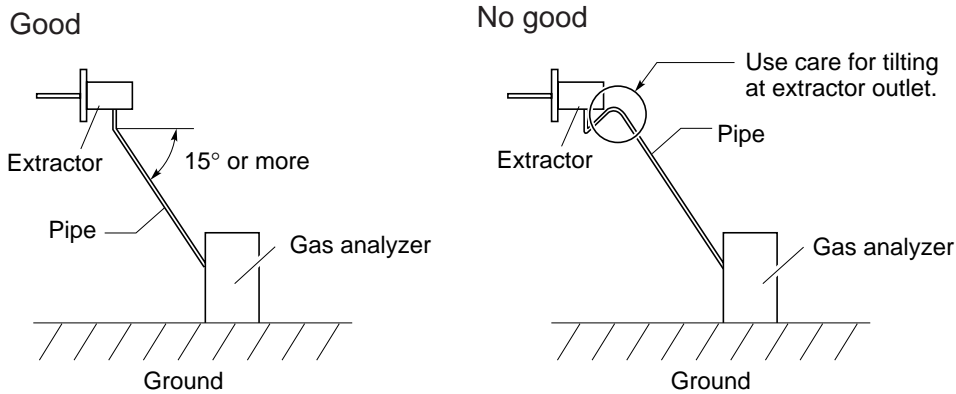

- 4) So as not to cause a condensation at the outlet of the gas extractor, provide heating means or thermal insulation according to particular installation conditions and location.

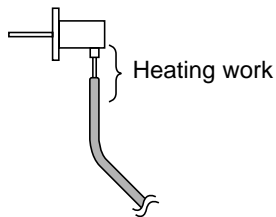

**Note) Use the heating tube in cold climate or if SO<sub>2</sub> meter is included.**

---

## 2.4 Piping of analyzer interior

### (1) Piping of sample gas

Without cutting the gas tube, directly lead it in through “Sample gas lead-in” located on the upper side of the locker, and connect it to the moisture separator on the left side in the locker.

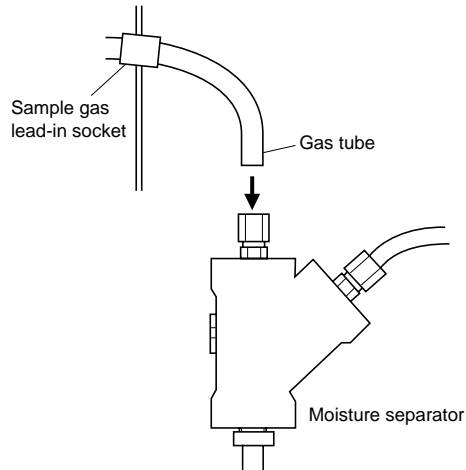

### (2) Piping of exhaust and moisture

- 1) Exhaust  
Discharge the gas through “Exhaust 1” and “Exhaust 2” on the lower side of the locker to an appropriate place outdoors.
- 2) Moisture  
Discharge the moisture through “Drain” located on the lower side of the locker.  
Install the drain line from the locker so that the moisture will not stay.  
Provide a thermal insulation means if there is a fear of freezing in winter.
- 3) Use tubes made of Teflon or other non-corrosive materials.

# 3. WIRING

## 3.1 External connection diagram

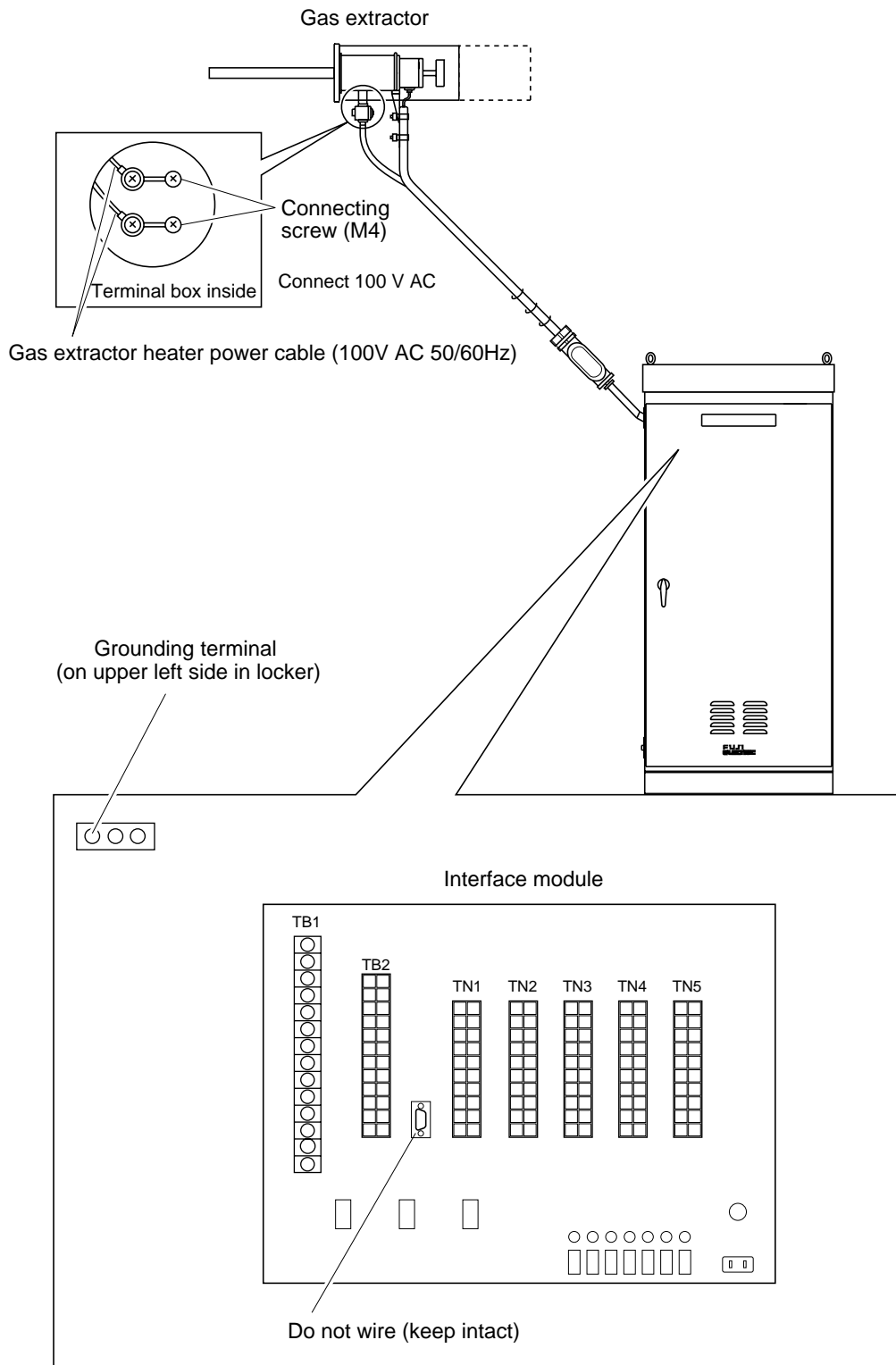

Fig. 3-1 Wiring procedure

\* For details of these terminal blocks, see page 3.2.1.

## 3.2 Wiring

### ⚠ CAUTION

- Entrust the wiring to a specialist or the supplier. Poor wiring may cause shock hazard or injury.
- Enforce construction of class-D grounding wire by all means. If the specified grounding construction is neglected, a shock hazard or fault may be caused.

#### Caution to wiring electrician

**For avoiding shock hazard, fire and injury, be sure to observe the following.**

- Before wiring, be sure to turn off the main power supplies. Otherwise, a shock hazard may occur.
- As a ground wire, use 600V-IV wire of 2 mm<sup>2</sup> or thicker having a sufficient dielectric strength. Use of a wrong ground wire may cause shock hazard or malfunction.
- Input/output wires should have proper diameters meeting the rated current of the gas analyzer. If a wire which cannot endure the rating is used, a fire may occur.
- For connection to input and output terminal blocks, be sure to use solderless terminals.
- For branching the output wires, use a terminal block.
- Be sure to fasten the input/output wires on the floor, wall, etc. and put guards on the wires.
- Do not install the instrument near high frequency heating furnace, electric welding machine or others which considerably disturb the power waveforms. Do not share their power supplies either.

#### (1) Material of cable

Power cable	CV wire, line dia. 2 mm <sup>2</sup> to 5.5mm <sup>2</sup>
Signal cable	CVV wire or SVV-S wire, dia. 1.25 mm <sup>2</sup> or more
Earth cable	600-IV line, line dia. 2 mm <sup>2</sup> to 5.5mm <sup>2</sup>

#### (2) Wiring at outdoor installation

When the analyzer is installed outdoors, water-proof cable glands (A25a) (different arrangement) can be mounted at the cable leading-in port of the analyzer to prevent entry of fluid. As shown below, pass the cable into the water-proof cable glands and tighten them. If conduits are used for wiring, employ fixtures matching them.

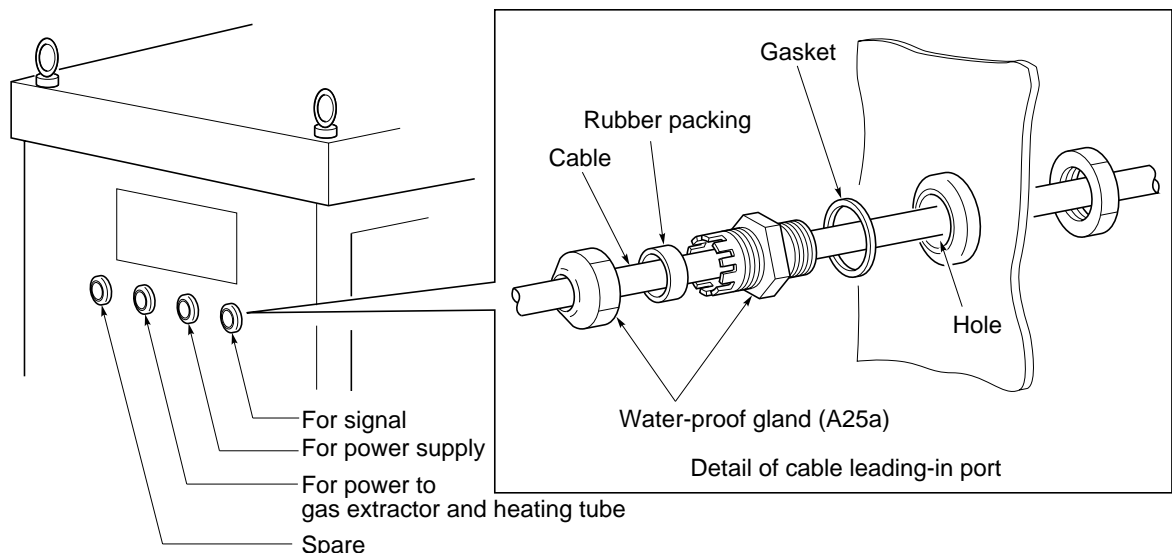
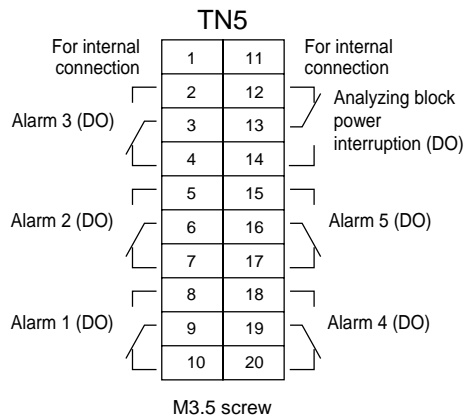
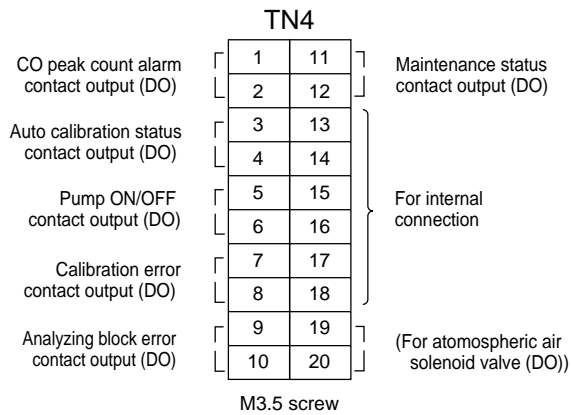
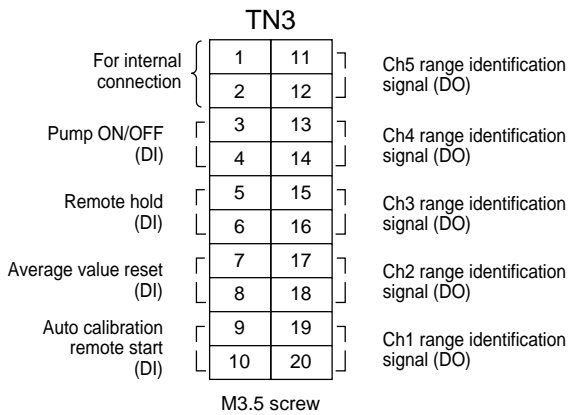
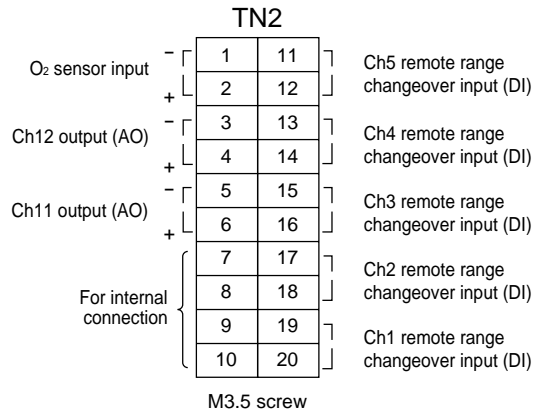
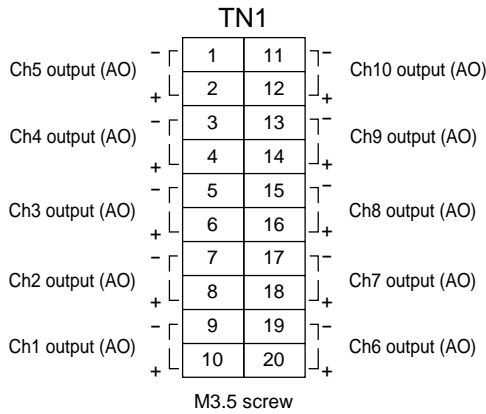
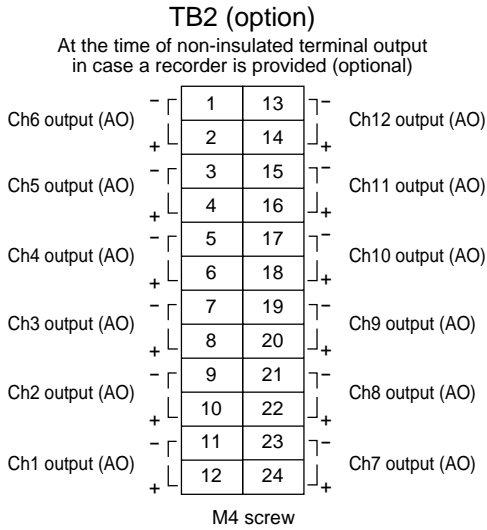
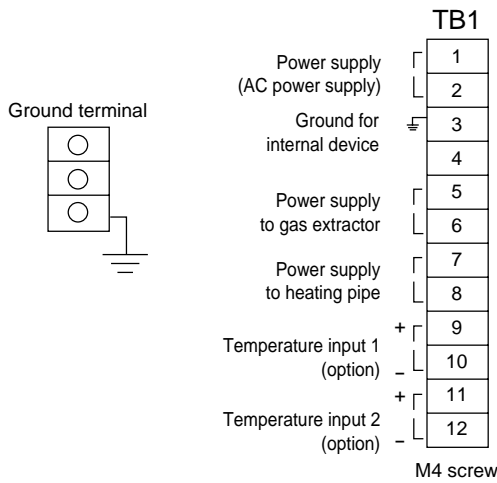

Fig. 3-2

### 3.2.1 Terminal blocks (retain particular manufacturing specifications, if any)

#### (1) List of terminal blocks



- For correspondence between channel No. and output item, refer to “correspondence between measurement channel and measured value” in Table 3-1.

## (2) Description on terminal block

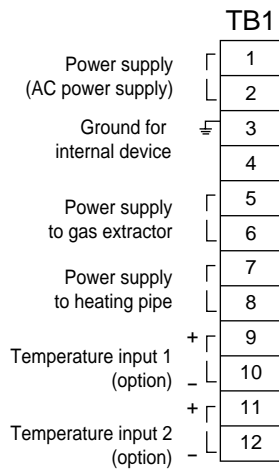

### Terminal block <TB1>

- Between 1 – 2 : Terminal block for main power supply input
- 3 : **Ground for internal device. Connect nothing others. Connect the ground for power supply to ground terminal located on upper left side in locker.**
- Between 5 – 6 : Terminal block for extractor power supply
- Between 7 – 8 : Terminal block for heating pipe power supply
- Between 9 – 10 : Temperature input 1
- Between 11–12 : Temperature input 2

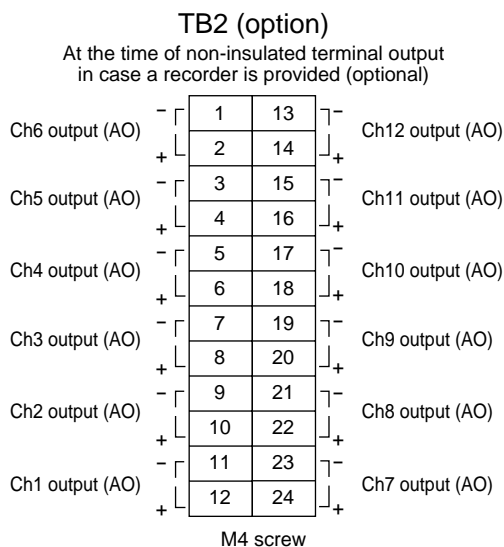

### Terminal block <TB2> Option

This terminal block is added for non-isolated output and when the recorder is built-in.

- Between 1 – 2 : Ch6 output (AO)
- Between 3 – 4 : Ch5 output (AO)
- Between 5 – 6 : Ch4 output (AO)
- Between 7 – 8 : Ch3 output (AO)
- Between 9 – 10 : Ch2 output (AO)
- Between 11 – 12 : Ch1 output (AO)
- Between 13– 14 : Ch12 output (AO)
- Between 15– 16 : Ch11 output (AO)
- Between 17 – 18 : Ch10 output (AO)
- Between 19 – 20 : Ch9 output (AO)
- Between 21 – 22 : Ch8 output (AO)
- Between 23 – 24 : Ch7 output (AO)

- For correspondence between channel No. and output item, refer to “correspondence between measurement channel and measured value” in Table 3-1.

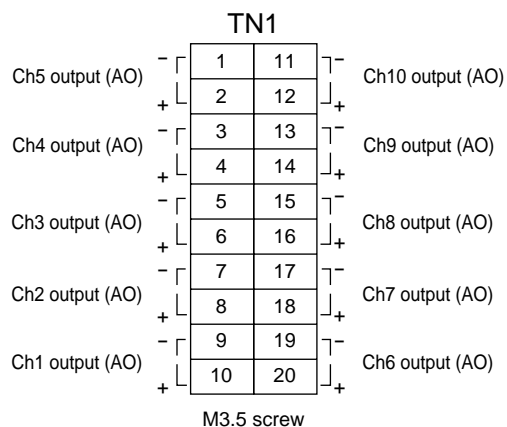

### Terminal block 1 <TN1>

Terminal block for analog output

Between 1 – 2 : Ch5 output

Between 3 – 4 : Ch4 output

Between 5 – 6 : Ch3 output

Between 7 – 8 : Ch2 output

Between 9 – 10 : Ch1 output

Between 11 – 12 : Ch10 output

Between 13 – 14 : Ch9 output

Between 15 – 16 : Ch8 output

Between 17– 18 : Ch7 output

Between 19– 20 : Ch6 output

- For correspondence between channel No. and output item, refer to “correspondence between measurement channel and measured value” in Table 3-1.

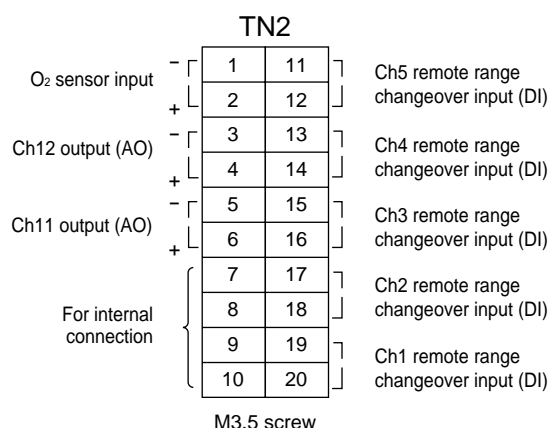

### Terminal block 2 <TN2>

Between 1– 2 : For O<sub>2</sub> sensor input. (Input for our Zirconia oxygen sensor. Must not be used unless O<sub>2</sub> sensor is added.)

Between 3– 4 : Ch12 output

Between 5– 6 : Ch11 output

Between 7– 10 : For internal connection. Must not be wired. (Must not be used as junction terminal.)

Between 11– 12 : Ch5 remote range changeover input

Between 13 – 14 : Ch4 remote range changeover input

Between 15 – 16 : Ch3 remote range changeover input

Between 17– 18 : Ch2 remote range changeover input

Between 19– 20 : Ch1 remote range changeover input

- When remote range changeover input is open, high range is selected. And when this input is shorted, low range is selected. For details of action, refer to Instruction manual.
- For correspondence between channel No. and output item, refer to “correspondence between measurement channel and measured value” in Table 3-1.
- The channel No. in a remote range input is effective only when it corresponds to an instantaneous value. The converted value is linked with the range of instantaneous value.

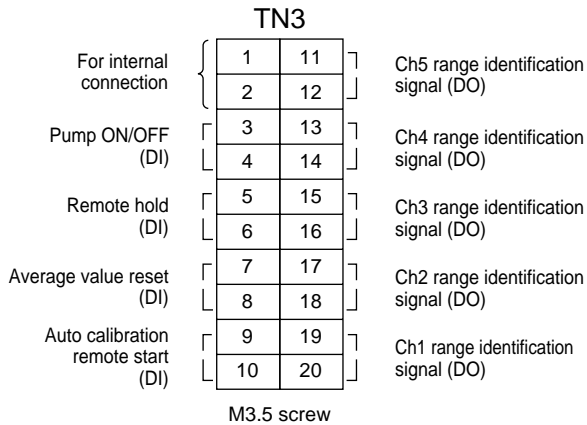

### Terminal block 3 <TN3>

Between 1 – 2 : For internal connection. Must not be wired. (Must not be used as junction terminal.)

Between 3 – 4 : Pump ON/OFF contact input. Pump ON when open. Pump OFF when closed.

**Note: If an NOx meter and a CO meter are used in mixture, there is a possibility where the reading of the CO meter rises when the pump stops running, because minor CO is generated due to chemical changes in the NO<sub>2</sub>/NO converter and this CO accumulates. If this phenomenon becomes a problem, hold the output before pump stop.**

Between 5 – 6 : Remote hold input. No hold when open. Output hold when closed.

Between 7 – 8 : Average value reset input. Closing the contact input (for at 1.5 sec min.) resets O<sub>2</sub> average and converted average simultaneously. Opening it restarts the average value.

Between 9 – 10 : Automatic calibration remote start input. Open input after closing for at least 1.5 seconds starts the automatic calibration whether automatic calibration setting is ON or OFF.

Between 11 – 12 : Ch5 range identification signal

Between 13 – 14 : Ch4 range identification signal

Between 15 – 16 : Ch3 range identification signal

Between 17– 18 : Ch2 range identification signal

Between 19– 20 : Ch1 range identification signal

- Range identification signal is close at Low range or open at High range.
- The channel No. in a range identification signal is effective only when it corresponds to an instantaneous value. The range of converted value is linked with that of instantaneous value.

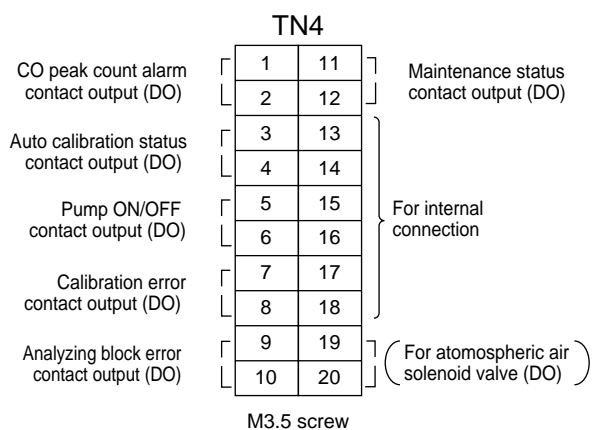

### Terminal block 4 <TN4>

- Between 1 – 2 : Peak count alarm contact output. Conductive at preset peak count or more. Open otherwise. For setting and action, refer to instruction manual “3.6 Peak Alarm Setting.”
- Between 3 – 4 : Automatic calibration status contact output. Conductive during automatic calibration. Open otherwise.
- Between 5 – 6 : Pump ON/OFF contact output. (Used for turning ON/OFF the pump. Already wired. Do not rewire.)
- Between 7 – 8 : Calibration error contact output. Conductive when error is produced at zero or span calibration. Normally open.
- Between 9 – 10 : Conductive when analyzer unit error is produced. Normally open.
- Between 11 – 12 : Conductive when maintenance status switch is ON.
- Between 13 – 18 : For internal connection. Must not be wired. (Must not be used as junction terminal.)
- Between 19– 20 : Contact output for atmospheric air solenoid valve connection. (Already wired if atmospheric air is used as zero gas. Must not be wired otherwise.)

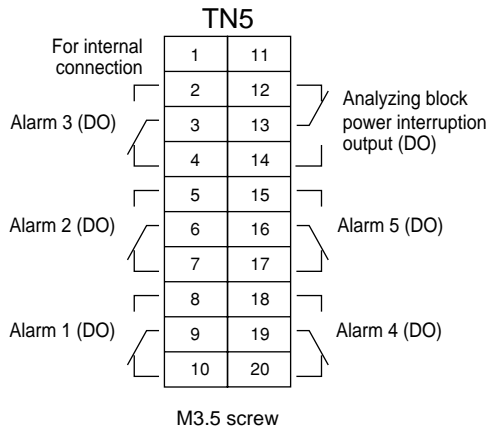

### Terminal block 5 <TN5>

- Between 2 – 4 : Alarm 3 (initial state)  
Conductive at 2-3 and open at 3-4 when a measured value exceeds the limit value. Open at 2-3 and conductive at 3-4 otherwise.
- Between 5 – 7 : Alarm 2 (initial state)  
Conductive at 5-6 and open at 6-7 when a measured value exceeds the limit value. Open at 5-6 and conductive at 6-7 otherwise.
- Between 8 – 10 : Alarm 1 (initial state)  
Conductive at 8-9 and open at 9-10 when a measured value exceeds the limit value. Open at 8-9 and conductive at 9-10 otherwise.
- Between 12 – 14 : Analyzing block power interruption output.  
Conductive at 12-13 and open at 13-14 when analyzer unit is energized. Open at 12-13 and conductive at 13-14 when analyzer unit is de-energized.
- Between 15 – 17 : Alarm 5 (initial state)  
Conductive at 15-16 and open at 16-17 when a measured value exceeds the limit value. Open at 15-16 and conductive at 16-17 otherwise.
- Between 18 – 20 : Alarm 4 (initial state)  
Conductive at 18-19 and open at 19-20 when a measured value exceeds the limit value. Open at 18-19 and conductive at 19-20 otherwise.
- Alarm responds only to an instantaneous value.

The following table gives measurement channels and their contents according to the symbols.

Table 3-1 Correspondence between measurement channel and measured value

Code symbol		Contents
4th digit	5th digit	
P	0	Ch1: NO <sub>x</sub>
A	0	Ch1: SO <sub>2</sub>
B	0	Ch1: CO
F	0	Ch1: NO <sub>x</sub> , Ch2: SO <sub>2</sub>
H	0	Ch1: NO <sub>x</sub> , Ch2: CO
L	0	Ch1: NO <sub>x</sub> , Ch2: SO <sub>2</sub> , Ch3: CO
M	0	Ch1: NO <sub>x</sub> , Ch2: SO <sub>2</sub> , Ch3: CO <sub>2</sub> , Ch4: CO
P	4 to G	Ch1: NO <sub>x</sub> , Ch2: O <sub>2</sub> , Ch3: Corrected NO <sub>x</sub> , Ch4: Corrected NO <sub>x</sub> average, Ch5: O <sub>2</sub> average
A	4 to G	Ch1: SO <sub>2</sub> , Ch2: O <sub>2</sub> , Ch3: Corrected SO <sub>2</sub> , Ch4: Corrected SO <sub>2</sub> average, Ch5: O <sub>2</sub> average
B	4 to G	Ch1: CO, Ch2: O <sub>2</sub> , Ch3v Corrected CO, Ch4v Corrected CO average, Ch5: O <sub>2</sub> average
F	4 to G	Ch1: NO <sub>x</sub> , Ch2: SO <sub>2</sub> , Ch3: O <sub>2</sub> , Ch4: Corrected NO <sub>x</sub> , Ch5: Corrected SO <sub>2</sub> , Ch6: Corrected NO <sub>x</sub> average, Ch7: Corrected SO average, Ch8: O average
H	4 to G	Ch1: NO <sub>x</sub> , Ch2: CO, Ch3: O <sub>2</sub> , Ch4: Corrected NO <sub>x</sub> , Ch5: Corrected CO, Ch6: Corrected NO <sub>x</sub> average, Ch7: Corrected C average, Ch8: O average
L	4 to G	Ch1: NO <sub>x</sub> , Ch2: SO <sub>2</sub> , Ch3: CO, Ch4: O <sub>2</sub> , Ch5: Corrected NO <sub>x</sub> , Ch6: Corrected SO <sub>2</sub> , Ch7: Corrected CO, Ch8: Corrected NO <sub>x</sub> average, Ch9: Corrected SO average, Ch10: Corrected C average, Ch11: O average
M	4 to G	Ch1: NO <sub>x</sub> , Ch2: SO <sub>2</sub> , Ch3: CO <sub>2</sub> , Ch4: CO, Ch5: O <sub>2</sub> , Ch6: Corrected NO <sub>x</sub> , Ch7: Corrected SO <sub>2</sub> , Ch8: Corrected CO, Ch9: Corrected NO <sub>x</sub> average, Ch10: Corrected SO average, Ch11: Corrected C average, Ch12: O average

---

## **Fuji Electric Systems Co., Ltd.**

### **Head Office**

Gate City Ohsaki, East Tower, 11-2, Osaki 1-chome,  
Shinagawa-ku, Tokyo 141-0032, Japan  
<http://www.fesys.co.jp/eng>

### **Instrumentation Div.**

#### **International Sales Dept.**

No.1, Fuji-machi, Hino-city, Tokyo 191-8502, Japan  
Phone: 81-42-585-6201, 6202 Fax: 81-42-585-6187  
<http://www.fic-net.jp/eng>

---