

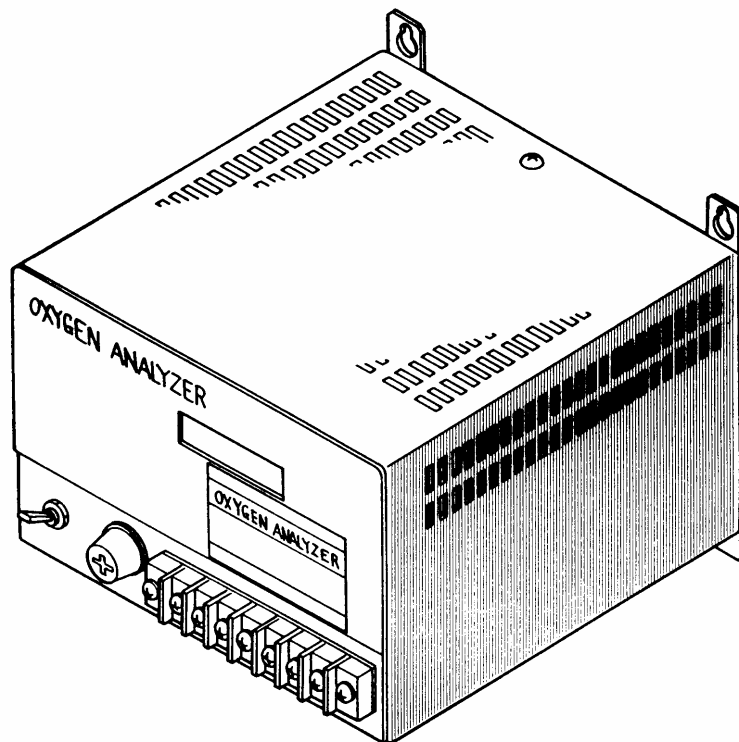

Instruction Manual

ZIRCONIA OXYGEN DETECTOR SERVICE MANUAL

TYPE: ZFK 3, 4, 7



CONTENTS

1. PREFACE.....	2
2. MEASUREMENT PRINCIPLE.....	2
3. ADJUSTMENT	3
3.1 Zero (Air) Adjustment	3
3.2 Span Adjustment.....	3
4. TROUBLE CHECK SHEET	4
5. REPAIR.....	5
APPENDIX Wiring Diagram.....	6
Output characteristic table.....	7

1. PREFACE

This service manual explains repair and adjustment procedure of the Zirconia oxygen detector (ZFK 3, 4, 7) as a single unit.

This manual is intended for use with the instruction manual (INZ-TN4ZFK3).

2. MEASUREMENT PRINCIPLE

When yttria-stabilized zirconia ceramic is heated to high-temperature, only the oxygen ion becomes a movable solid electrolyte. In a zirconia element, the both sides of which are fitted with a platinum electrode, the electrode reactions in the following expressions occur for the oxygen concentrations P_1 and P_2 ($P_1 > P_2$).

Electrode of P_1 side $O_2 + 4e \rightarrow 2O^{2-}$ (negative electrode)

Electrode of P_2 side $2O^{2-} \rightarrow O_2 + 4e$ (positive electrode)

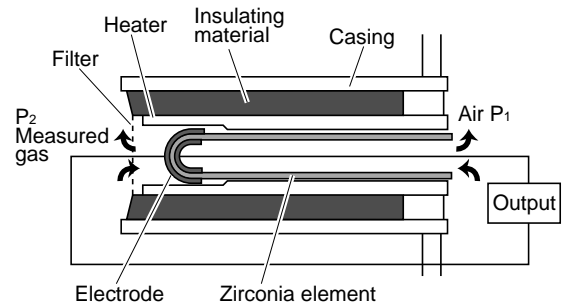

Fig.1 Detector structure

That is, the oxygen ion moves from the P_1 side, where oxygen concentration is higher, to P_2 side, where it is lower. This energy for moving the ion generates the electric force (E) indicated in the following expression.

$$E = \frac{RT}{4F} \ln \frac{P_1(O_2)}{P_2(O_2)} \quad (V)$$

$$= 50.74 \log \frac{P_1(O_2)}{P_2(O_2)} \quad (mV) \quad (\text{at } 800^\circ C)$$

* Coefficient 50.74 is the value when the zirconia element is $750^\circ C$. (The sensor unit becomes $750^\circ C$ with $800^\circ C$ temperature control.)

E : Electric force

$P_1(O_2)$: Comparative (Air) oxygen concentration

$P_2(O_2)$: Oxygen concentration in the measured gas

R : Gas constant $8.3144 \text{ (J}\cdot\text{mol}^{-1}\cdot\text{K}^{-1}\text{)}$

T : Absolute temperature

F : Faraday constant $9.649 \times 10^4 \text{ (c}\cdot\text{mol}^{-1}\text{)}$

Therefore, unknown oxygen concentration $P_2(O_2)$ can be calculated from the electric force (E).

3. ADJUSTMENT

3.1 Zero (Air) Adjustment

- 1) Remove the 3 screws fixing the case cover.
- 2) Feed the zero gas (Dry Air) through the sample gas inlet (on the lower side of the main unit) at the specified flow rate (0.5L /min).
- 3) After the voltage indication between the external terminals block (4) and (5) (the terminal block on the front panel 7P) is stabilized (feed zero gas for 2 to 3 minutes), adjust the indication to $0 \pm 1\text{mV}$ by VRZ on the printed board; ZFK 3, 4.

For ZFK7, make sure that the indication is within $\pm 3\text{mV}$. (No adjustment)

3.2 Span Adjustment

- 1) Feed the span gas (1 to 2% O_2/N_2) at the specified flow rate.
- 2) After the indication is stabilized, adjust it by VRS; ZFK 3, 4

Find the adjustment value using the following expression.

$$E \text{ (Output:V)} = 0.3812 \times \log 21/P_x \quad P_x: \text{Calibration gas concentration}$$

Example) In case of 1.1% O_2/N_2

$$E = 0.3812 \times \log 21/1.1 = 0.488^{\text{V}}$$

Make an adjustment with the VRs control so that 0.488^{V} is obtained.

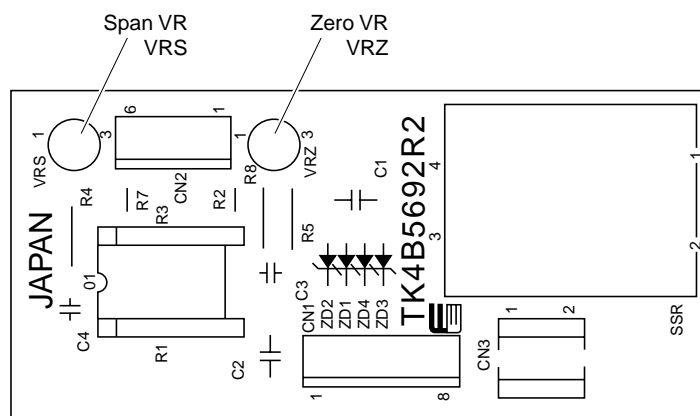

Fig.2 Printed board mounting diagram; ZFK 3, 4

For ZFK7, make sure that the indication is within 50 to 70mV when the gas with concentration of 1 to 2 % O_2/N_2 is flowed. (Refer to Appendix Table 2.) (No adjustment)

4. TROUBLE CHECK SHEET

Phenomena	Cause	Checking methods (normal value)	Protective measures
Slow response	Sensor element deterioration	Change over between zero and span gas and check if 60 seconds or longer is needed for 90% response.	Replace
Sample gas is not supplied or output is abnormal.	Sensor outlet is clogged with crystallized sulfate mist.	Visually check for clogging of the outlet of the gas introduction case.	Remove the clogging. Replace with a gas introduction case (provided with gas outlet pot).
Output is unstable	ZFK 3, 4 Disconnection of connector or poor contact	Check if the connector is disconnected or move the connector part to check for the indication change.	Repair
	Disturbance noise	Check if output is hunting.	Eliminate noise.
	Sensor element deterioration	Flow zero/span gas continuously for 10 minutes or so, and observe the indication status.	Replace the sensor element.
Output is not deflected or remains the same.	Fuse is blown out or power is not supplied.	Check the fuse and the supply voltage specification.	Replace the fuse or check the power supply.
	ZFK 3, 4 Disconnection of connector or poor contact	Check if the connector is disconnected or move the connector part to check for the indication change.	Repair
	Sensor is defective.	Change over between zero and span gas and check for the indication change. Remove one end of the sensor terminal block (3) – (4), and check for continuity. The range should be within 2 to 3 Ω .	Replace the sensor element.
	Solid relay is defective.	When 24V DC is applied to the outer end (7) – (8) (-), check if AC power between (1) – (2) on the sensor element is turned on or off. (Check with a tester.)	Replace the printed board or the solid relay.
	Printed board is defective.	Change over between zero and span gas and check if the voltage value between the sensor outer end (5) – (6) (+) indicates as shown below. Air: $\pm 3\text{mV}$ or lower 1 to 2% O_2/N_2 : 50 to 70mV.	Replace the printed board or the solid relay or sensor element.
	ZFK 3, 4 Constant voltage power supply is defective.	Check if the CN2 of the constant voltage power supply indicates $12 \pm 0.1\text{V}$.	Replace the constant voltage power supply.
	Temperature controller is defective.	Check if the temperature indication is constant in a range of $800 \pm 5 \text{ }^\circ\text{C}$.	Replace the temperature controller.
Output swings over.	Measuring range is exceeded.	Flow measured gas after zero/span calibration.	Review the specifications.

5. REPAIR

(1) Replacement of the sensor element

- 1) Change the measuring gas line to the Air atmosphere and then turn off the power switch. When the device is operating, install an oxygen meter by bypass piping. Leave the device for about 30 minutes till it cools down.
- 2) Remove the case cover (a).
- 3) Remove the 6 wires connected to the sensor terminal block (b) and the 3 M4 screws fixing the sensor (c).
- 4) Pull out the sensor (d) from the sensor case (e), and assemble the new sensor in reverse order of disassembly. After wiring is checked, perform energization and running to calibrate zero/span.
When replacing the sensor element, also replace the packing with a new one.

(2) Replacement of the sensor case

- 1), 2) Follow the procedure in Item (1).
- 3) Remove the 3 M4 screws fixing the sensor (c).
- 4) Remove the 2 screws fixing the sensor case from the bottom of the main unit, and remove the sensor case from the top.
- 5) Assemble a new sensor in reverse order of disassembly.

(3) Replacement of the printed board (ZFK 3, 4)

- 1), 2) Follow the procedure in Item (1).
- 3) Remove the 8 wires connected to the terminal block of the printed board and 3 screws fixing the printed board.
- 4) Assemble a new printed board in reverse order of disassembly. Perform energization and running to calibrate zero/span.

(4) Replacement of the temperature controller

- 1), 2) Follow the procedure in Item (1).
- 3) Remove the 2 screws from the top of the temperature controller and the socket from the backside, and pull out the controller forward.
- 4) Assemble a new temperature controller in reverse order of disassembly.

(5) Replacement of the constant voltage power supply (ZFK 3, 4)

- 1), 2) Follow the procedure in Item (1).
- 3) Remove the 5 wires and the 2 side fixing screws connected to the upper terminal block of the constant voltage power supply (g), and remove the constant voltage power supply.
- 4) Assemble a new constant voltage power supply in reverse order of disassembly.

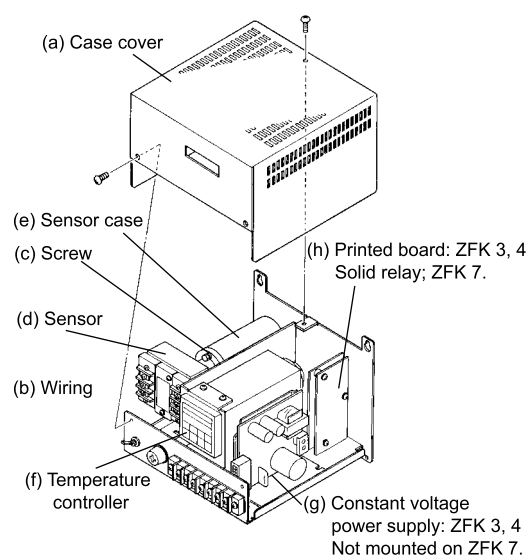
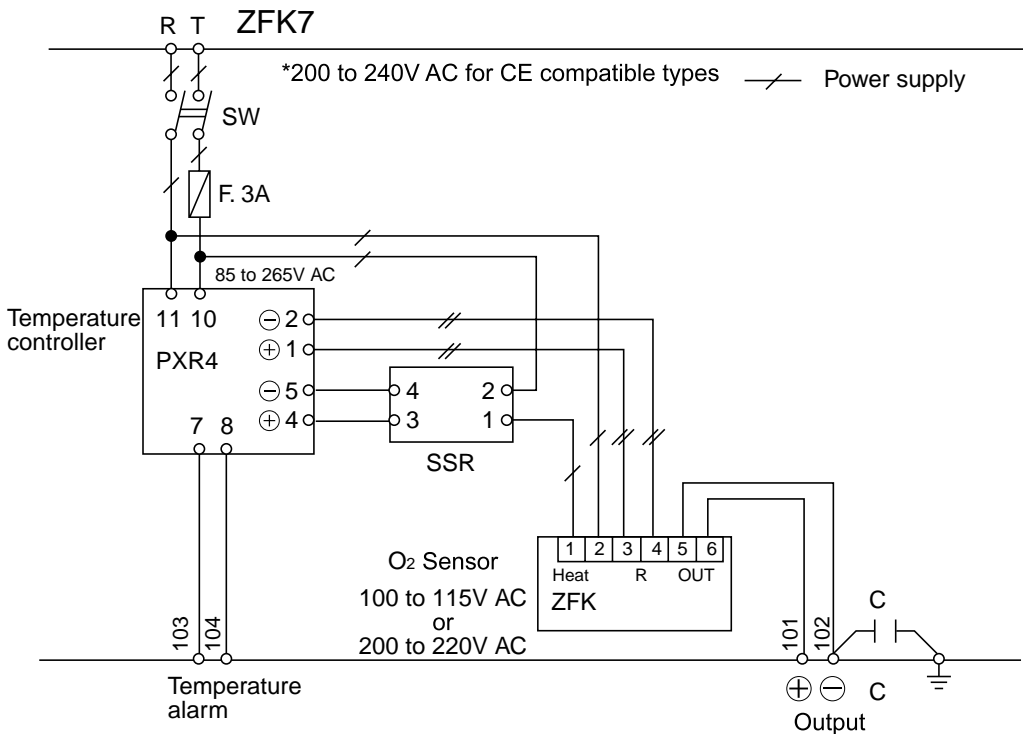
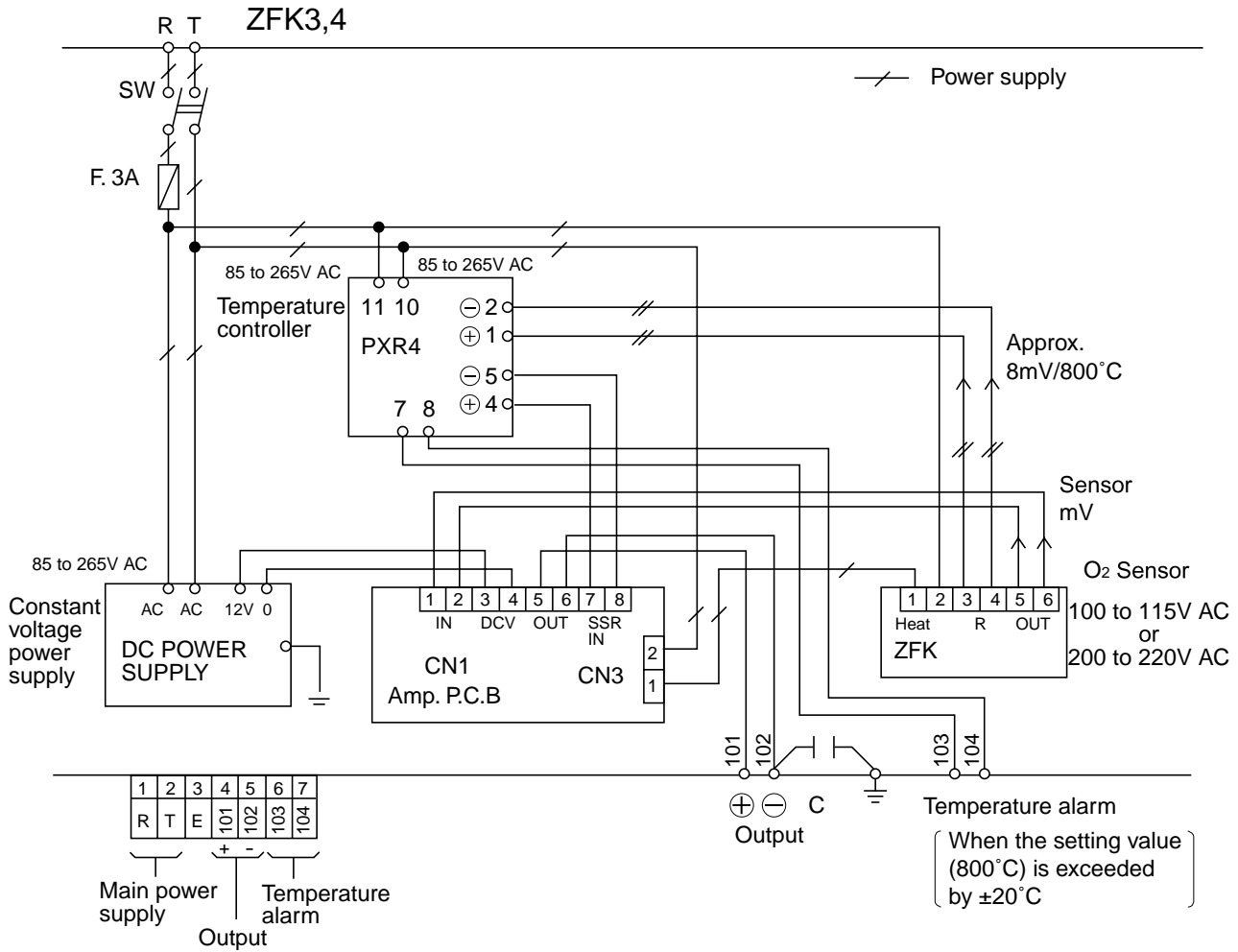

Fig.3 Internal diagram of the oxygen analyzer

APPENDIX Wiring Diagram



APPENDIX TABLE 1

ZFK 3, 4 Zirconia oxygen Analyzer Output characteristic table (ZFK 3, 4 output)

%O ₂	OUTPUT (mV)
0.05	1000
0.1	885.3
0.5	618.8
1.0	504.0
2.0	389.3
3.0	322.2
4.0	274.5
5.0	237.6
6.0	207.4
7.0	181.9
8.0	159.8
9.0	140.3
10.0	122.8
11.0	107.1

%O ₂	OUTPUT (mV)
12.0	92.7
13.0	79.4
14.0	67.1
15.0	55.7
16.0	45.0
17.0	35.0
18.0	25.5
19.0	16.6
20.0	8.8
21.0	0.0
22.0	-7.7
23.0	-15.1
24.0	-22.1
25.0	-28.9

$E (\text{OUTPUT : V}) = 0.3812 \log 21/\text{O}_2\%$

APPENDIX TABLE 2

ZFK 3, 4, 7 Zirconia oxygen Analyzer Detector Output characteristic (internal sensor)

%O ₂	OUTPUT (mV)
0.01	168.57
0.02	153.3
0.03	144.36
0.04	138.02
0.05	133.1
0.1	117.83
0.2	102.56
0.3	93.62
0.4	87.28
0.5	82.36
0.6	78.35
0.7	74.95
0.8	72.01
0.9	69.41
1.0	67.09
2.0	51.82
3.0	42.88
4.0	36.54
5.0	31.62
6.0	27.61

%O ₂	OUTPUT (mV)
7.0	24.21
8.0	21.27
9.0	18.67
10.0	16.35
11.0	14.25
12.0	12.33
13.0	10.57
14.0	8.93
15.0	7.41
16.0	5.99
17.0	4.66
18.0	3.40
19.0	2.21
20.0	1.08
20.6	0.4238
21.0	0
22.0	-1.025
23.0	-2.005
24.0	-2.943
25.0	-3.84

$E (\text{OUTPUT : mV}) = 50.74 \log 21/\text{O}_2\%$

Fuji Electric Systems Co., Ltd.

Head Office

Gate City Ohsaki, East Tower, 11-2, Osaki 1-chome,
Shinagawa-ku, Tokyo 141-0032, Japan
<http://www.fesys.co.jp/eng>

Instrumentation Div.

International Sales Dept.

No.1, Fuji-machi, Hino-city, Tokyo 191-8502, Japan
Phone: 81-42-585-6201, 6202 Fax: 81-42-585-6187
<http://www.fic-net.jp/eng>
